



Emotron VS10 / VS30 AC drive

0.33 ... 3 hp

Use in UL approved systems



Mounting and switch on instruction

This page intentionally left blank!

Contents

1 General information	5
1.1 Read first, then start	5
1.2 Notations and conventions	5
1.2.1 Product code	5
2 Safety instructions	6
2.1 Basic safety measures	6
2.2 Residual hazards	7
2.3 Application as directed	7
3 Product description	8
4 Mounting	9
4.1 Important notes	9
4.2 Mechanical installation	10
4.3 Electrical installation	13
4.3.1 Important notes	13
4.3.2 1-phase mains connection 230/240 V	14
4.3.2.1 Fusing and terminal data	16
4.3.3 1/3-phase mains connection 230/240 V	17
4.3.3.1 Fusing and terminal data	19
4.3.4 3-phase mains connection 480 V	20
4.3.4.1 Fusing and terminal data	22
4.3.5 CANopen/Modbus	23
5 Commissioning	24
5.1 Important notes	24
5.2 Before initial switch-on	24
5.3 Initial switch-on / functional test with terminal control	25
6 Technical data	27
6.1 Standards and operating conditions	27
6.2 1-phase mains connection 230/240 V	29
6.2.1 Rated data	29
6.3 1/3-phase mains connection 230/240 V	30
6.3.1 Rated data	30
6.4 3-phase mains connection 480 V	31
6.4.1 Rated data	31

This page intentionally left blank!

1 General information

1.1 Read first, then start

WARNING!

Read this documentation thoroughly before carrying out the installation and commissioning.

- ▶ Please observe the safety instructions!



Information and tools with regard to the Lenze products can be found on the Internet:

<http://www.emotron.com> / file-archive

1.2 Notations and conventions

1.2.1 Product code, examples:

VS10-23-1P7-20-CM

VS10-40-1P7-20-CM

VS	10	23	1P7	20	CM
Series	1-phase	230V	Rated current 1.7A	IP20	CANopen & Modbus
VS	30	40	1P7	20	CM
Series	3-phase	400-480VV	Rated current 1.7A (400V)	IP20	CANopen & Modbus

:

2 Safety instructions

2.1 Basic safety measures

Disregarding the following basic safety measures may lead to severe personal injury and damage to material assets!

The product

- must only be used as directed.
- must never be commissioned if they display signs of damage.
- must never be technically modified.
- must never be commissioned if they are not fully mounted.
- must never be operated without required covers.

Connect/disconnect all pluggable terminals only in deenergised condition.

Only remove the product from the installation in the deenergised state.

Insulation resistance tests between 24V control potential and PE: According to EN 61800-5-1, the maximum test voltage must not exceed 110 VDC.

Observe all specifications of the corresponding documentation supplied. This is the precondition for safe and trouble-free operation and for obtaining the product features specified.

The procedural notes and circuit details described in this document are only proposals. It is up to the user to check whether they can be adapted to the particular applications. Lenze does not take any responsibility for the suitability of the procedures and circuit proposals described.

The product must only be used by qualified personnel. IEC 60364 or CENELEC HD 384 define the skills of these persons:

- They are familiar with installing, mounting, commissioning, and operating the product.
- They have the corresponding qualifications for their work.
- They know and can apply all regulations for the prevention of accidents, directives, and laws applicable at the place of use.

Observe the specific notes in the other chapters!





2.2 Residual hazards

The user must take the residual hazards mentioned into consideration in the risk assessment for his/her machine/system.

If the above is disregarded, this can lead to severe injuries to persons and damage to material assets!

Product

Observe the warning labels on the product!

Icon	Description
	Electrostatic sensitive devices: Before working on the inverter, the staff must ensure to be free of electrostatic charge!
	Dangerous electrical voltage Before working on the inverter, check whether all power connections are dead! After mains OFF, power connections X100 and X105 carry a dangerous electrical voltage for the time specified on the inverter!
	High leakage current: Carry out fixed installation and PE connection in compliance with EN 61800–5–1 or EN 60204–1 !
	Hot surface: Use personal protective equipment or wait until devices have cooled down!

Motor

If there is a short circuit of two power transistors, a residual movement of up to 180°/number of pole pairs can occur at the motor! (For 4-pole motor: residual movement max. $180^\circ/2 = 90^\circ$).

This residual movement must be taken into consideration by the user for his/her risk assessment.

2.3 Application as directed

- The product must only be operated under the operating conditions prescribed in this documentation.
- The product meets the protection requirements of 2014/35/EU: Low-Voltage Directive.
- The product is not a machine in terms of 2006/42/EC: Machinery Directive.
- Commissioning or starting the operation as directed of a machine with the product is not permitted until it has been ensured that the machine meets the regulations of the EC Directive 2006/42/EC: Machinery Directive; observe EN 60204–1.
- Commissioning or starting the operation as directed is only allowed when there is compliance with the EMC Directive 2014/30/EU.
- The harmonised standard EN 61800–5–1 is used for the inverters.
- The product is not a household appliance, but is only designed as component for commercial or professional use in terms of EN 61000–3–2.
- In accordance with EN 61800–3, the product can be used in drive systems that have to comply with the categories given in the technical data.

In residential areas, the product may cause EMC interferences. The operator is responsible for taking interference suppression measures.

Product description

3 Product description

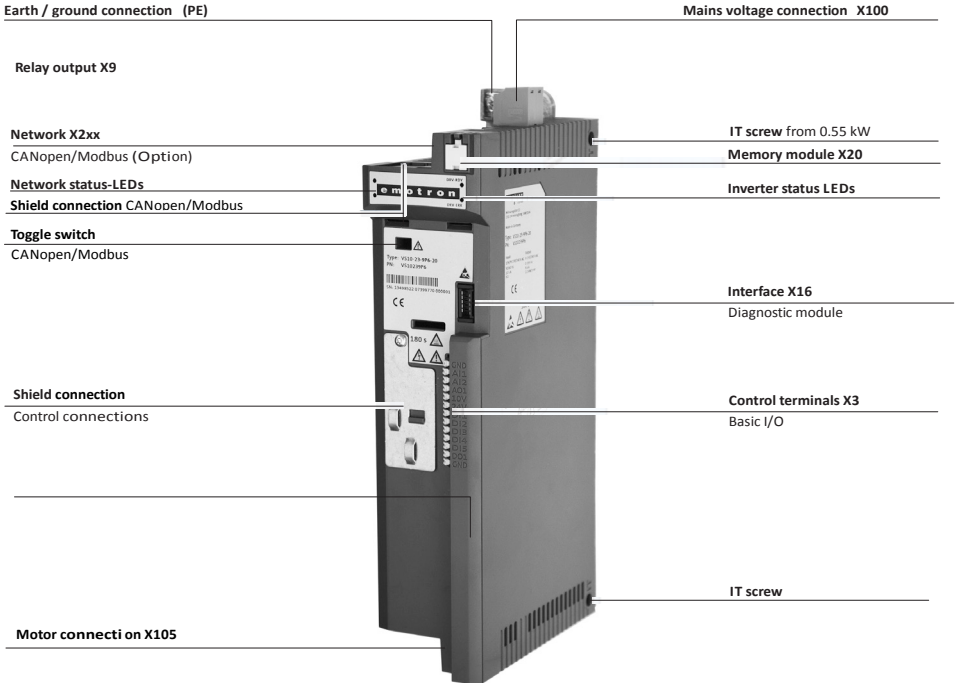

4 Mounting

4.1 Important notes

DANGER!

Dangerous electrical voltage

Possible consequence: death or severe injuries

- ▶ All work on the inverter must only be carried out in the deenergised state.
 - ▶ After switching off the mains voltage, wait for at least 3 minutes before you start working.
-

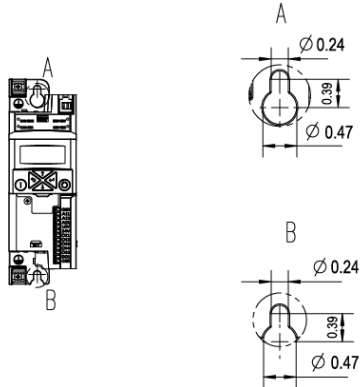
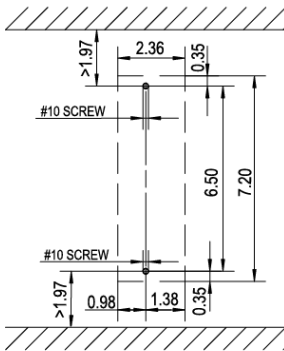
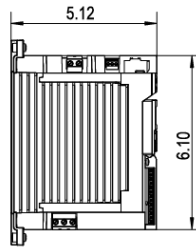
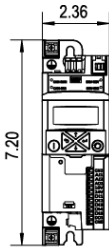
4.2 Mechanical installation**Dimensions 0.33 hp ... 0.5 hp**

8800305

All dimensions in inches

Dimensions 0.75 hp ... 1 hp

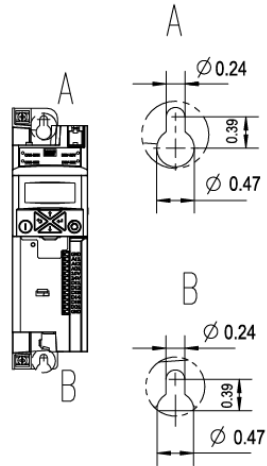
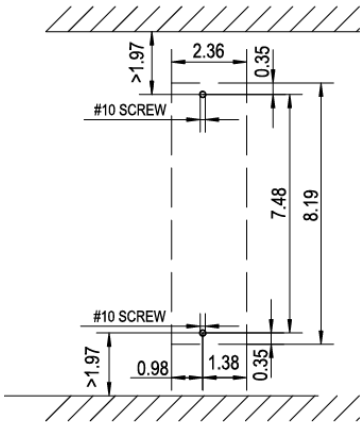
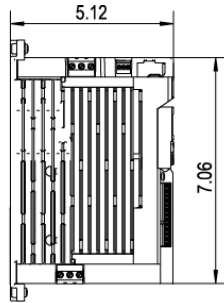
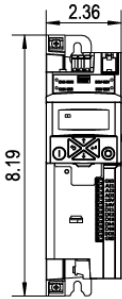

8800306

All dimensions in inches

4 Mounting

Dimensions 1.5 hp ... 3 hp

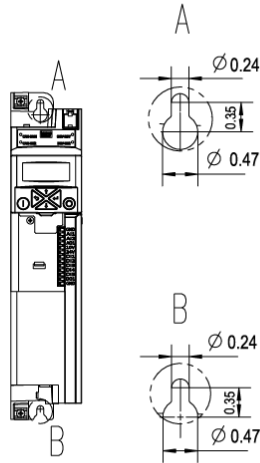
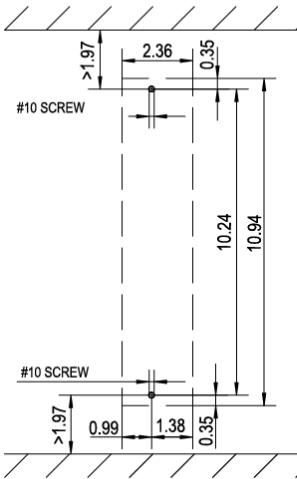
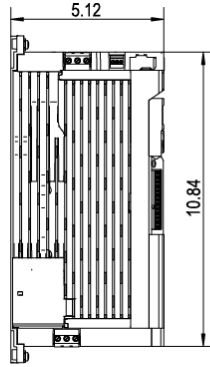
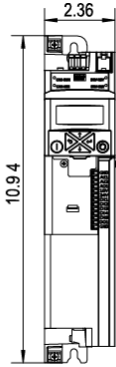

8800307

All dimensions in inches

4.3 Electrical installation

4.3.1 Important notes

WARNING!

- ▶ The integral solid state short circuit protection included in the inverter does not provide branch circuit protection. Branch circuit protection must be provided in accordance with the National Electrical Code and any additional local codes.
- ▶ -----
- ▶ La protection statique intégrée contre les courts-circuits n'offre pas la même protection que le dispositif de protection du circuit de dérivation. Un tel dispositif doit être fourni, conformément au National Electrical Code et aux autres dispositions applicables au niveau local.

WARNING!

- ▶ The inverter (PE) terminals connections must be connected to system earth / ground.
- ▶ Earth / ground impedance must conform to the requirements of national and local industrial safety regulations and all applicable electrical codes.
- ▶ The integrity of all earth / ground connections should be periodically checked.
- ▶ -----
- ▶ Les raccordements (PE) des bornes du variateur doivent être reliés à la terre.
- ▶ L'impédance de terre doit être conforme aux exigences des réglementations nationales et locales en vigueur en matière de sécurité industrielle, ainsi qu'aux dispositions applicables en matière d'électricité.
- ▶ Il convient de vérifier l'intégrité de toutes les liaisons à la masse à intervalles réguliers.

WARNING!

- ▶ Use 75°C copper wire only, except for control circuits.
- ▶ -----
- ▶ Utiliser exclusivement des conducteurs en cuivre 75 °C, sauf pour la partie commande.

NOTICE!

- ▶ Internal overload protection rated for 125 % of the rated FLA.
- ▶ -----
- ▶ Protection contre les surcharges conçue pour se déclencher à 125 % de l'intensité assignée à pleine charge.

Mounting

Electrical installation

1-phase mains connection 230/240 V

4.3.2 1-phase mains connection 230/240 V

WARNING!

- ▶ Suitable for use on a circuit capable of delivering not more than 5,000 rms symmetrical amperes, 240 V maximum.
 - ▶ When protected by fuses rated as given in tables below.
 - ▶ When protected by a circuit breaker having an interrupting rating not less than 5,000 rms symmetrical amperes, 240 V maximum rated as given in tables below.
 - ▶ -----
 - ▶ Convenient aux circuits non susceptibles de délivrer plus de 5.000 ampères symétriques eff., maximum 240 V.
 - ▶ Avec une protection par des fusibles du calibre indiqué dans les tableaux ci-dessous.
 - ▶ Avec protection par un disjoncteur à pouvoir de coupure nominal d'au moins 5.000 ampères symétriques eff., 240 V maximum, se reporter aux tableaux ci-dessous pour connaître les caractéristiques assignées.
-

The wiring diagram is valid for Emotron VS10 inverters.

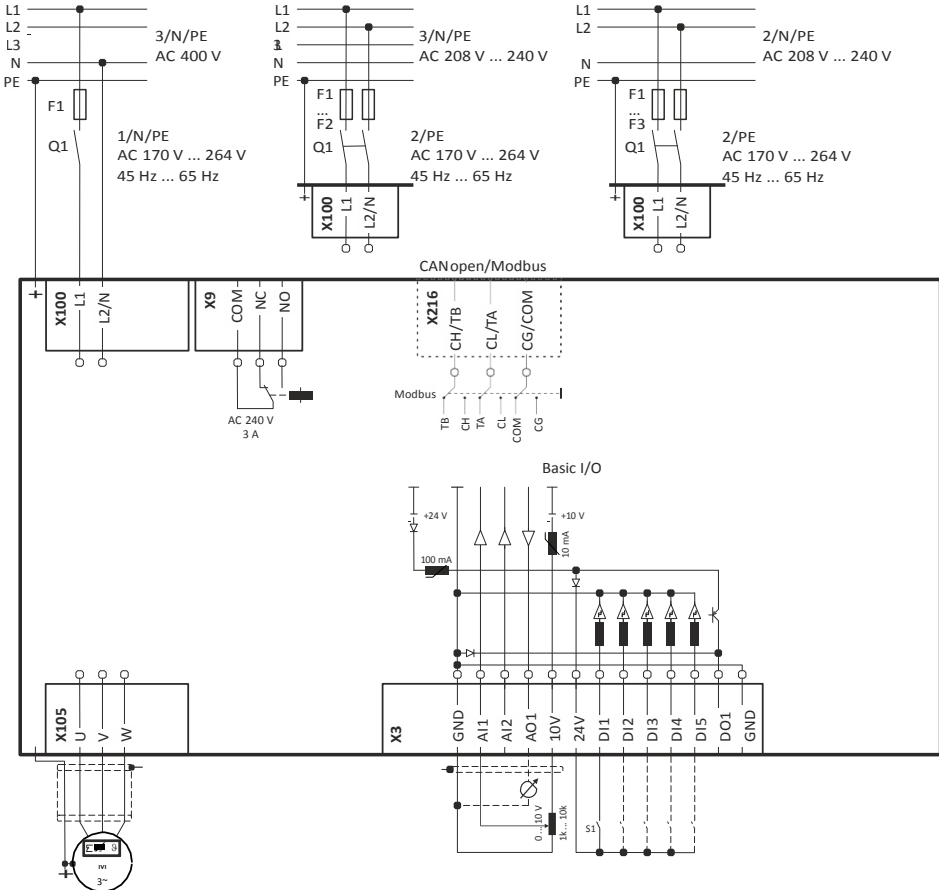

Fig. 1: Wiring example

- S1 Run/Stop
- Fx Fuses

- Q1 Mains contactor
- Dashed line = options

Mounting

Electrical installation

1-phase mains connection 230/240 V

4.3.2.1 Fusing and terminal data

Inverter		VS10231P7	VS10232P4	VS10233P2	VS10234P2	VS10236P0	VS10237P0	VS10239P6	
Cable installation in compliance with		UL							
Operation		without mains choke							
Fuse									
Characteristic		all acc. to UL 248/CC							
Max. rated current	A	15	15	15	15	30	30	30	
Circuit breaker									
Characteristic									
Max. rated current	A	15	15	15	15	30	30	30	
Operation		with mains choke							
Fuse									
Characteristic		all acc. to UL 248/CC							
Max. rated current	A	15	15	15	15	30	30	30	
Circuit breaker									
Characteristic									
Max. rated current	A	15	15	15	15	30	30	30	
Earth-leakage circuit breaker		≥ 30 mA, type A or B							
Mains connection									
Connection		X100							
Connection type		Screw terminal							
Min. cable cross-section	AWG	18							
Max. cable cross-section	AWG	12				10			
Stripping length	inch	0.32							
Tightening torque	lb-in	4.4				6.2			
Required tool		0.5 x 3.0				0.6 x 3.5			
Motor connection									
Connection		X105							
Connection type		Screw terminal							
Min. cable cross-section	AWG	18							
Max. cable cross-section	AWG	12							
Stripping length	inch	0.32							
Tightening torque	lb-in	4.4							
Required tool		0.5 x 3.0							
PE connection									
Connection		PE							
Connection type		PE screw							
Min. cable cross-section	AWG	18							
Max. cable cross-section	AWG	10							
Stripping length	inch	0.39							
Tightening torque	lb-in	11							
Required tool		0.8 x 5.5							

4.3.3 1/3-phase mains connection 230/240 V

**WARNING!**

- ▶ Suitable for use on a circuit capable of delivering not more than 5,000 rms symmetrical amperes, 240 V maximum.
 - ▶ When protected by fuses rated as given in tables below.
 - ▶ When protected by a circuit breaker having an interrupting rating not less than 5,000 rms symmetrical amperes, 240 V maximum rated as given in tables below.
 - ▶ -----
 - ▶ Convenient aux circuits non susceptibles de délivrer plus de 5.000 ampères symétriques eff., maximum 240 V.
 - ▶ Avec une protection par des fusibles du calibre indiqué dans les tableaux ci-dessous.
 - ▶ Avec protection par un disjoncteur à pouvoir de coupure nominal d'au moins 5.000 ampères symétriques eff., 240 V maximum, se reporter aux tableaux ci-dessous pour connaître les caractéristiques assignées.
-

4 **Mounting**
 Electrical installation
 1/3-phase mains connection 230/240 V

The wiring diagram is valid for Emotron VS30 inverters.

Emotron VS30 inverters do not have an integrated EMC filter in the AC mains supply.



In order to comply with the EMC requirements according to EN 61800-3, an external EMC filter according to IEC EN 60939 has to be used.

The user must prove that the EN 61800-3 requirements for conformity are fulfilled.

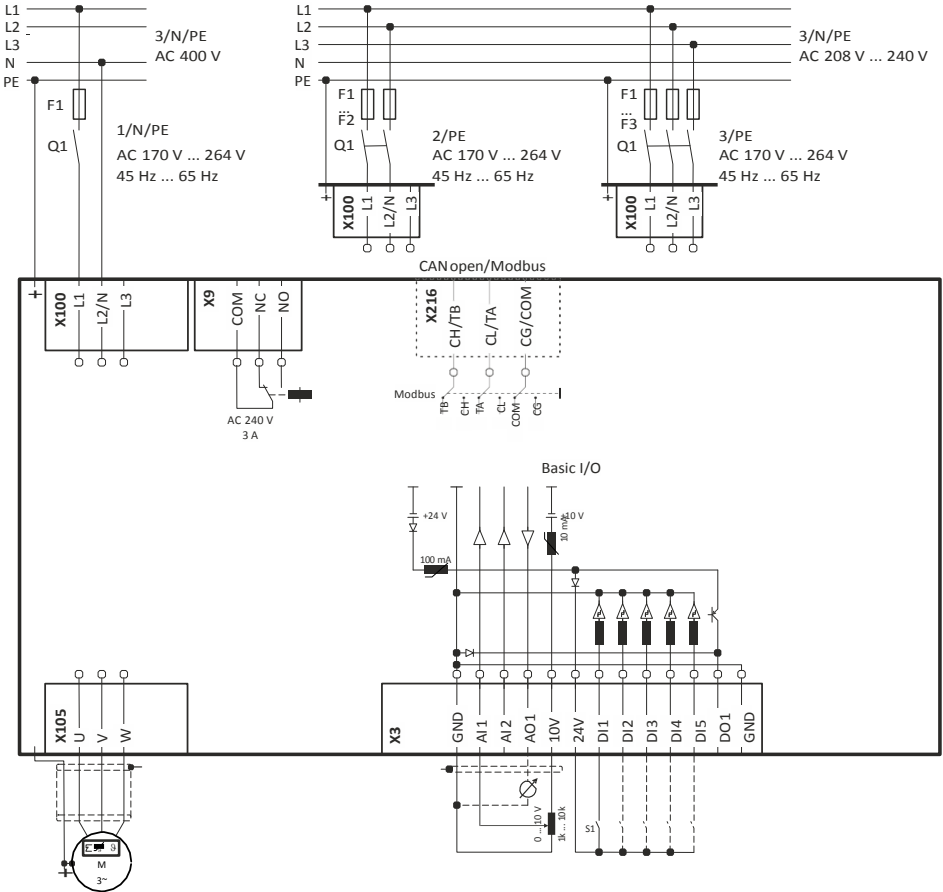

Fig. 2: Wiring example

S1 Run/Stop
 Fx Fuses

Q1 Mains contactor
 --- Dashed line = options

4.3.3.1 Fusing and terminal data

Inverter		VS30231P7	VS30232P4	VS30233P2	VS30234P2	VS30236P0	VS30237P0	VS30239P6
Cable installation in compliance with		UL						
Operation		without mains choke						
Fuse								
Characteristic		all acc. to UL 248/CC						
Max. rated current	A	15	15	15	15	30	30	30
Circuit breaker								
Characteristic								
Max. rated current	A	15	15	15	15	30	30	30
Operation		with mains choke						
Fuse								
Characteristic		all acc. to UL 248/CC						
Max. rated current	A	15	15	15	15	30	30	30
Circuit breaker								
Characteristic								
Max. rated current	A	15	15	15	15	30	30	30
Earth-leakage circuit breaker		≥ 30 mA, type A or B ≥ 30 mA, type B						
Mains connection								
Connection		X100						
Connection type		Screw terminal						
Min. cable cross-section	AWG	18						
Max. cable cross-section	AWG	12				10		
Stripping length	inch	0.32						
Tightening torque	lb-in	4.4				6.2		
Required tool		0.5 x 3.0				0.6 x 3.5		
Motor connection								
Connection		X105						
Connection type		Screw terminal						
Min. cable cross-section	AWG	18						
Max. cable cross-section	AWG	12						
Stripping length	inch	0.32						
Tightening torque	lb-in	4.4						
Required tool		0.5 x 3.0						
PE connection								
Connection		PE						
Connection type		PE screw						
Min. cable cross-section	AWG	18						
Max. cable cross-section	AWG	10						
Stripping length	inch	0.39						
Tightening torque	lb-in	11						
Required tool		0.8 x 5.5						

Mounting

Electrical installation

Fusing and terminal data

4.3.4 3-phase mains connection 480 V

WARNING!

- ▶ Suitable for use on a circuit capable of delivering not more than 5,000 rms symmetrical amperes, 480/277 V maximum.
 - ▶ When protected by fuses rated as given in tables below.
 - ▶ -----
 - ▶ Convenient aux circuits non susceptibles de délivrer plus de 5.000 ampères symétriques eff., maximum 480/277 V.
 - ▶ Avec une protection par des fusibles du calibre indiqué dans les tableaux ci-dessous.
-

The wiring diagram is valid for Emotron VS30 inverters.

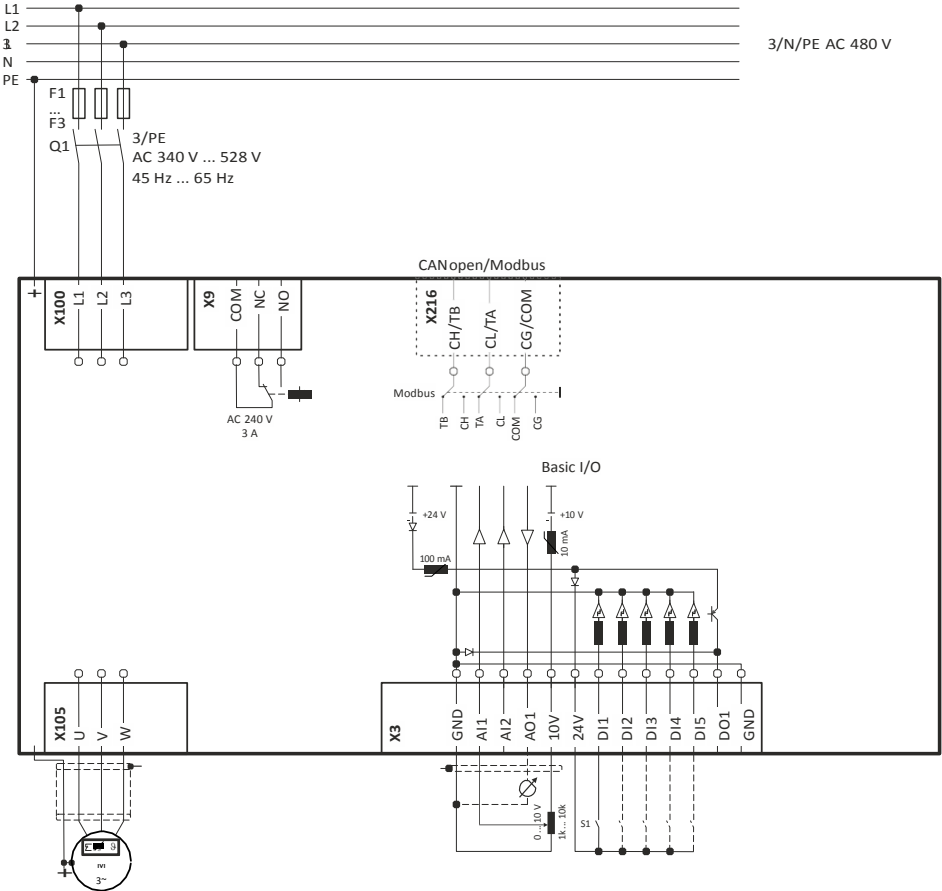

Fig. 3: Wiring example

- S1 Run/Stop
- Fx Fuses

- Q1 Mains contactor
- Dashed line = options

Mounting

Electrical installation
Fusing and terminal data

4.3.4.1 Fusing and terminal data

Inverter		VS30401P3	VS30401P8	VS30402P4	VS30403P2	VS30403P9	VS30405P6
Cable installation in compliance with		UL					
Operation		without mains choke					
Fuse							
Characteristic		all acc. to UL 248/CC					
Max. rated current	A	15	15	15	15	15	15
Operation		with mains choke					
Fuse							
Characteristic		all acc. to UL 248/CC					
Max. rated current	A	15	15	15	15	15	15
Earth-leakage circuit breaker		≥ 30 mA, type B					
Mains connection							
Connection		X100					
Connection type		Screw terminal					
Min. cable cross-section	AWG	18					
Max. cable cross-section	AWG	12					
Stripping length	inch	0.32					
Tightening torque	lb-in	4.4					
Required tool		0.5 x 3.0					
Motor connection							
Connection		X105					
Connection type		Screw terminal					
Min. cable cross-section	AWG	18					
Max. cable cross-section	AWG	12					
Stripping length	inch	0.32					
Tightening torque	lb-in	4.4					
Required tool		0.5 x 3.0					
PE connection							
Connection		PE					
Connection type		PE screw					
Min. cable cross-section	AWG	18					
Max. cable cross-section	AWG	10					
Stripping length	inch	0.39					
Tightening torque	lb-in	11					
Required tool		0.8 x 5.5					

4.3.5 CANopen/Modbus

Typical topologies

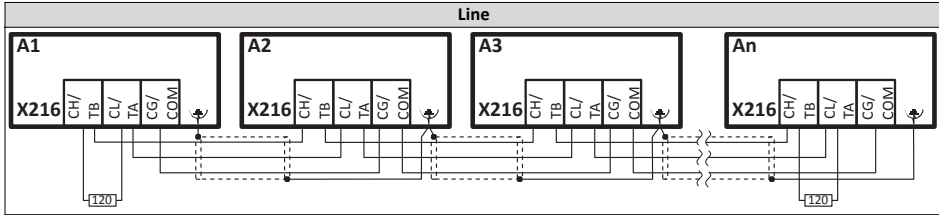

Basic network settings

1. Use toggle switch on front of the inverter to select CANopen or Modbus network.

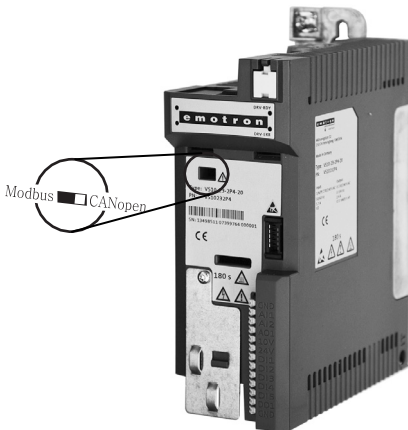

2. Set node address and baud rate via corresponding parameters.

Terminal description	CANopen/Modbus	
Connection		X216
Connection type		Spring terminal
Min. cable cross-section	AWG	22
Max. cable cross-section	AWG	12
Stripping length	inch	0.39
Tightening torque	lb-in	-
Required tool		0.4 x 2.5



The network must be terminated with a 120 Ω resistor at the physically first and last node. Connect resistor to terminals CH/TB and CL/TA.

Commissioning

Important notes

5 Commissioning

5.1 Important notes



WARNING!

Incorrect settings during commissioning may cause unexpected and dangerous motor and system movements.
Possible consequence: death, severe injuries or damage to property

- ▶ Clear hazardous area.
 - ▶ Observe safety instructions and safety clearances.
-

5.2 Before initial switch-on

Prevent injury to persons and damage to property. Check the following before switching on the mains voltage:

- Is the wiring complete and correct?
- Are there no short circuits and earth faults?
- Is the motor circuit configuration (star/delta) adapted to the output voltage of the inverter?
- Is the motor connected in-phase (direction of rotation)?
- Does the "emergency stop" function of the entire plant operate correctly?

5.3 Initial switch-on / functional test with terminal control

Target: achieve rotation of the motor connected to the inverter as quickly as possible.

Requirements:

- The connected motor matches the inverter in terms of power.
- The parameter settings comply with the delivery status (Lenze setting).

1. Preparation:

1. Wiring of power terminals. (Chapter 4.3 *Electrical installation*)
2. Wire digital inputs X3/DI1 (start/stop), X3/DI3 (reversal of rotation direction), and X3/DI4 (preset frequency setpoint 20 Hz).
3. Do not connect terminal X3/AI1 (analog setpoint selection) or connect it to GND.

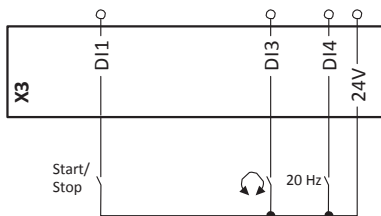

2. Switch on mains and check readiness for operation:

1. Switch on mains voltage.
2. Observe LED status displays "RDY" and "ERR" on the front of the inverter:
 - a) If the blue "RDY" LED is blinking and the red "ERR" LED is off, the inverter is ready for operation. The controller is inhibited.
You can now start the drive.
 - b) If the red "ERR" LED is lit permanently, a fault is pending.
Eliminate the fault before you carry on with the functional test.

LED status displays

"RDY" LED (blue)	"ERR" LED (red)	Status/meaning
off	off	No supply voltage.
blinking (2 Hz)	off	Inverter inhibited.
	lit every 1.5 s for a short time	Inverter inhibited, no DC-bus voltage.
	blinking fast (4 Hz)	Inverter inhibited, warning active.
	on	Inverter inhibited, fault active.
on	off	Inverter enabled.
	blinking fast (4 Hz)	Inverter enabled, warning active.
	blinking (1 Hz)	Inverter enabled, quick stop as response to a fault active.

Carrying out the functional test

1. Start drive:

1. Start inverter: X3/DI1 = HIGH.
The drive rotates with 20 Hz.
2. Activate preset frequency setpoint 1 (20 Hz) as speed setpoint: X3/DI4 = HIGH.
The drive rotates with 20 Hz in the opposite direction.
3. Optional: activate the function for the reversal of rotation direction.
 - a) X3/DI3 = HIGH.
The drive rotates with 20 Hz in the opposite direction.
 - b) Deactivate the function for the reversal of rotation direction again: X3/DI3 = LOW.
Speed characteristic (example)

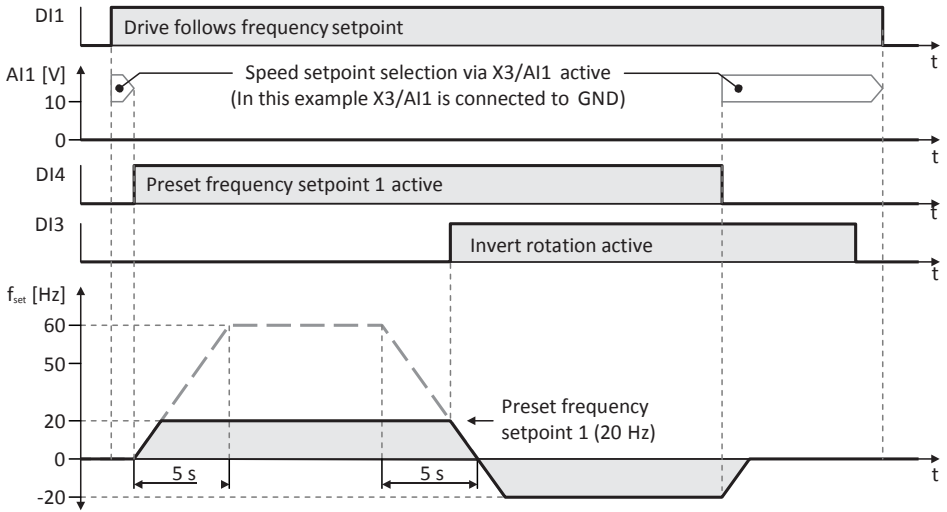

2. Stop drive:

1. Deactivate preset frequency setpoint 1 again: X3/DI4 = LOW.
2. Stop inverter again: X3/DI1 = LOW.

The functional test is completed.



The commissioning process of the drive solution is described in a separate commissioning instruction which can be found on the Internet in our download area:

<http://www.emotron.com/file-archive>

6 Technical data

6.1 Standards and operating conditions

Conformities		
CE	2014/35/EU	Low-Voltage Directive
	2014/30/EU	EMC Directive (reference: CE-typical drive system)
EAC	TR TC 004/2011	Eurasian conformity: safety of low voltage equipment
	TP TC 020/2011	Eurasian conformity: electromagnetic compatibility of technical means
RoHS 2	2011/65/EU	Restrictions for the use of specific hazardous materials in electric and electronic devices
Approvals		
UL	UL 61800-5-1	for USA and Canada (requirements of the CSA 22.2 No. 274)
Energy efficiency		
Class IE2	EN 50598-2	Reference: Lenze setting (switching frequency 8 kHz variable)
Degree of protection		
IP20	EN 60529	
Type 1	NEMA 250	Protection against contact
Open type		only in UL-approved systems
Insulation resistance		
Overvoltage category III	EN 61800-5-1	0 ... 2000 m a.m.s.l.
Overvoltage category II		above 2000 m a.m.s.l.
Control circuit isolation		
Safe mains isolation by double/reinforced insulation	EN 61800-5-1	
Protective measures against		
Short circuit		
Earth fault		Earth fault strength depends on the operating status
Overvoltage		
Motor stalling		
Motor overtemperature		I ² t monitoring
Leakage current		
> 3.5 mA AC, > 10 mA DC	EN 61800-5-1	Observe regulations and safety instructions!
Mains switching		
3-time mains switching in 1 min		Cyclic, without any restrictions
Starting current		
≤ 3 x rated mains current		
Mains systems		
TT		Voltage to earth/ground: max. 300V
TN		
IT		Apply the measures described for IT systems!
		IT systems are not relevant for UL-approved systems
Operation on public supply systems		
Implement measures to limit the radio interference to be expected:		The machine or plant manufacturer is responsible for compliance with the requirements for the machine/plant!
< 1 kW: with mains choke	EN 61000-3-2	
> 1 kW at mains current ≤ 16 A: without additional measures		
Mains current > 16 A: with mains choke or mains filter, with	EN 61000-3-12	RSCE: short-circuit power ratio at the connection point of the machine/plant to the public network.

dimensioning for rated power. $R_{sc} \geq 120$ is to be met.		
Requirements to the shielded motor cable		
Capacitance per unit length		
C-core-core/C-core-shield < 75/150 pF/m		$\leq 2.5 \text{ mm}^2 / \text{AWG 14}$
C-core-core/C-core-shield < 150/300 pF/m		$\geq 4 \text{ mm}^2 / \text{AWG 12}$
Electric strength		
$U_0/U = 0.6/1.0 \text{ kV}$		U = r.m.s. value external conductor/external conductor
		U_0 = r.m.s. value external conductor to PE
$U \geq 600 \text{ V}$	UL	U = r.m.s. value external conductor/external conductor
Climate		
1K3 (-25 ... +60 °C)	EN 60721-3-1	Storage
2K3 (-25 ... +70 °C)	EN 60721-3-2	Transport
3K3 (-10 ... +55 °C)	EN 60721-3-3	Operation
		Operation at a switching frequency of 8 or 16 kHz: above +40°C, reduce rated output current by 2.5%/°C
Site altitude		
0 ... 1000 m a.m.s.l.		
1000 ... 4000 m a.m.s.l.		Reduce rated output current by 5 %/1000 m
Pollution		
Degree of pollution 2	EN 61800-5-1	
Vibration resistance		
Transport		
2M2 (sine, shock)	EN 60721-3-2	
Operation		
Amplitude 1 mm	Germanischer Lloyd	5 ... 13.2 Hz
Acceleration resistant up to 0.7 g		13.2 ... 100 Hz
Amplitude 0.075 mm	EN 61800-5-1	10 ... 57 Hz
Acceleration resistant up to 1 g		57 ... 150 Hz
Noise emission		
Category C2	EN 61800-3	Type-dependent, for motor cable lengths see rated data
Noise immunity		
Meets requirement in compliance with	EN 61800-3	

6.2 1-phase mains connection 230/240 V

6.2.1 Rated data

The output currents apply to these operating conditions:

- At a switching frequency of 2 kHz or 4 kHz: Max. ambient temperature 113 °F.
- At a switching frequency of 8 kHz or 16 kHz: Max. ambient temperature 104 °F.

Inverter		VS10231P7	VS10232P4	VS10233P2	VS10234P2	VS10236P0	VS10237P0	VS10239P6
Rated power	hp	0.33	0.5	0.75	1	1.5	2	3
Mains voltage range		1/N/PE AC 170 V ... 264 V, 45 Hz ... 65 Hz						
Rated mains current								
without mains choke	A	4	5.7	7.6	10	14.3	16.7	22.5
with mains choke	A	3.6	4.8	7.1	8.8	11.9	13.9	16.9
Output current								
2 kHz	A	-	-	3.2	4.2	6	7	9.6
4 kHz	A	1.7	2.4	3.2	4.2	6	7	9.6
8 kHz	A	1.7	2.4	3.2	4.2	6	7	9.6
16 kHz	A	1.1	1.6	2.1	2.8	4	4.7	6.4
Power loss	W	15	20	25	33	42	50	70
Overcurrent cycle 180 s								
Max. output current	A	2.55	3.6	4.8	6.3	9	10.5	14.4
Overload time	s	60	60	60	60	60	60	60
Recovery time	s	120	120	120	120	120	120	120
Max. output current during the recovery time	A	1.28	1.8	2.4	3.15	4.5	5.25	7.2
Overcurrent cycle 15 s								
Max. output current	A	3.4	4.8	6.4	8.4	12	14	19.2
Overload time	s	3	3	3	3	3	3	3
Recovery time	s	12	12	12	12	12	12	12
Max. output current during the recovery time	A	1.28	1.8	2.4	3.15	4.5	5.25	7.2
Motor cable length								
shielded, without EMC	ft	164						
C2 residential area / industrial premises	ft	49			65			
Weight	lb	1.7		2.1		3		

6.3 1/3-phase mains connection 230/240 V

Emotron VS30 inverters do not have an integrated EMC filter in the AC mains supply.



In order to comply with the EMC requirements according to EN 61800-3, an external EMC filter according to IEC EN 60939 has to be used.

The user must prove that the EN 61800-3 requirements for conformity are fulfilled.

6.3.1 Rated data

The output currents apply to these operating conditions:

- At a switching frequency of 2 kHz or 4 kHz: Max. ambient temperature 113 °F.
- At a switching frequency of 8 kHz or 16 kHz: Max. ambient temperature 104 °F.

Inverter		VS30231P7	VS30232P4	VS30233P2	VS30234P2	VS30236P0	VS30237P0	VS30239P6
Rated power	hp	0.33	0.5	0.75	1	1.5	2	3
Mains voltage range		1/N/PE AC 170 V ... 264 V, 45 Hz ... 65 Hz						
Rated mains current								
without mains choke	A	4	5.7	7.6	10	14.3	16.7	22.5
with mains choke	A	3.6	4.8	7.1	8.8	11.9	13.9	16.9
Mains voltage range		3/PE AC 170 V ... 264 V, 45 Hz ... 65 Hz						
Rated mains current								
without mains choke	A	2.6	3.9	4.8	6.4	7.8	9.5	13.6
with mains choke	A	2	3	3.8	5.1	5.6	6.8	9.8
Output current								
2 kHz	A	-	-	3.2	4.2	6	7	9.6
4 kHz	A	1.7	2.4	3.2	4.2	6	7	9.6
8 kHz	A	1.7	2.4	3.2	4.2	6	7	9.6
16 kHz	A	1.1	1.6	2.1	2.8	4	4.7	6.4
Power loss	W	17	22	28	36	46	55	77
Overcurrent cycle 180 s								
Max. output current	A	2.55	3.6	4.8	6.3	9	10.5	14.4
Overload time	s	60	60	60	60	60	60	60
Recovery time	s	120	120	120	120	120	120	120
Max. output current during the recovery time	A	1.28	1.8	2.4	3.15	4.5	5.25	7.2
Overcurrent cycle 15 s								
Max. output current	A	3.4	4.8	6.4	8.4	12	14	19.2
Overload time	s	3	3	3	3	3	3	3
Recovery time	s	12	12	12	12	12	12	12
Max. output current during the recovery time	A	1.28	1.8	2.4	3.15	4.5	5.25	7.2
Motor cable length								
shielded, without EMC	ft	164						
Weight	lb	1.7		2.1		3		

6.4 3-phase mains connection 480 V

6.4.1 Rated data

The output currents apply to these operating conditions:

- At a switching frequency of 2 kHz or 4 kHz: Max. ambient temperature 113 °F.
- At a switching frequency of 8 kHz or 16 kHz: Max. ambient temperature 104 °F.

Inverter		VS30401P3	VS30401P8	VS30402P4	VS30403P2	VS30403P9	VS30405P6
Rated power	hp	0.5	0.75	1	1.5	2	3
Mains voltage range		3/PE AC 340 V ... 528 V, 45 Hz ... 65 Hz					
Rated mains current							
without mains choke	A	1.5	2.1	2.8	3.7	4.5	6.5
with mains choke	A	1.2	1.7	2.2	2.5	3.1	4.4
Output current							
2 kHz	A	-	1.6	2.1	3	3.5	4.8
4 kHz	A	1.1	1.6	2.1	3	3.5	4.8
8 kHz	A	1.1	1.6	2.1	3	3.5	4.8
16 kHz	A	0.7	1.1	1.4	2	2.3	3.2
Power loss	W	24	31	40	51	61	85
Overcurrent cycle 180 s							
Max. output current	A	1.65	2.4	3.15	4.5	5.25	7.2
Overload time	s	60	60	60	60	60	60
Recovery time	s	120	120	120	120	120	120
Max. output current during the recovery time	A	0.825	1.2	1.58	2.25	2.63	3.6
Overcurrent cycle 15 s							
Max. output current	A	2.2	3.2	4.2	6	7	9.6
Overload time	s	3	3	3	3	3	3
Recovery time	s	12	12	12	12	12	12
Max. output current during the recovery time	A	0.825	1.2	1.58	2.25	2.63	3.6
Motor cable length							
shielded, without EMC	ft	49	164				
C2 residential area / industrial premises	ft	49			65		
Weight	lb	1.7	2.1		3		

CG DRIVES & AUTOMATION

Mörsaregatan 12,

Box 222 25

SE- 250 24 Helsingborg,

Sweden

+46 42 16 99 00

Info: info.se@cglobal.com

Order: order.se@cglobal.com