



EMX™-P10 CONTROL UNIT

INSTRUCTION MANUAL - English

Applicable to the following model:
EMX-P10

Version 0

EMXTM-P10

CONTROL UNIT

INSTRUCTION MANUAL - English

Document number: 01-3092-01

Edition: r1

Date of edition: 2005-11-15

© Copyright Emotron AB 2005

Emotron AB reserves the right to change specifications in the text and illustrations without prior notice. The content of the document must not be copied without the consent of Emotron AB.

Safety instructions

On installation

- Read all the instructions before installation and use.
- The installation work shall be done by authorised personnel.
- General conditions and regulations for the installation and operation of electrical installations must be observed.
- Measures to protect against injury and machine damage shall be taken in accordance with local conditions and regulations.
- EMX-P10 is intended for fixed installation.
- Cables must not be connected or disconnected while the power supply is on.
- Check that the equipment is correctly connected before it goes into service; see instructions under Installation instructions.
- Faults due to incorrect installation or operation are not covered by the warranty.

During operation

- Measurements in the control unit, during operation, must only be carried out on the terminals and only by authorized personnel. Note: Take extreme care.
- Do not open or dismantle the unit when it is in operation.

On removal and scrapping

- The enclosure of the EMX-P10 is made of plastics. The material shall be handled and recycled in accordance with current legislation.
- The circuit board contains small amounts of tin and lead, which must be handled and recycled in accordance with current legislation.

Contents

1.	Product description.....	5
1.1	General description	5
1.2	Built-in features	5
1.2.1	Automatic purging operation	5
1.2.2	Soft start/soft stop	5
1.2.3	Rotation monitor.....	6
1.2.4	Alarm output	6
1.2.5	Operation indication	6
1.2.6	Speed control.....	6
1.2.7	The drive system's operating conditions at different control signals	7
2.	Installation instructions.....	9
2.1	Installing.....	9
2.1.1	Installing the rotation monitor	9
2.2	Wiring instructions.....	10
2.2.1	Tachometer signal	10
2.2.2	Setting DIP switches.....	11
2.2.3	Manual control with 10 kOhm potentiometer	12
2.2.4	Motor capacitor.....	13
2.2.5	Recommendations for EMC (electromagnetic compatibility)	13
2.2.6	Heat recovery on cooling.....	13
2.2.7	Direction of rotation.....	14
2.2.8	Connection of the motor	14
2.3	Operating status indication.....	15
3.	Maintenance and troubleshooting	17
3.1	Maintenance	17
3.2	Troubleshooting.....	17
3.3	On replacement	18

4.	Technical data	19
4.1	Accessories and documentation	20
4.2	Dimensions and hole outlines.....	20
5.	Appendix	21

1. Product description

1.1 General description

The EMX-P10 is a control unit which is specially adapted for speed regulation of rotary heat exchangers. A motor with gear and tachometer from Panasonic or Oriental Motor are intended to be connected to the control unit, with outputs of 25 or 40 W (max 0.7A). For other motor manufacturers or motor outputs contact the control unit supplier or Emotron AB.

The control unit has integrated motor capacitors of 1.5 μF or 2.3 μF , for 25 respectively 40 W motors. (External motor capacitors can also be used).

NOTE! Max motor current 0.7 A.

EMX-P10 has a number of functions which make the control unit fully suited to its task:

- No fine adjustment is required.
- All control inputs are isolated from the mains.
- Accepts most of the control signals on the market.
- The direction of rotation of the motor is reversible.
- Protection class IP54 or IP00.

1.2 Built-in features

1.2.1 Automatic purging operation

When the control signal drops below a certain value, for precise values see the installation description section, the heat exchanger's rotor rotates approximately 30 degrees every 10 minutes.

1.2.2 Soft start/soft stop

The control unit is equipped with soft start and soft stop functions. During intermittent operation start-up is adaptive to provide a fast and soft start.

1.2.3 Rotation monitor

The rotation monitor checks that the heat exchanger rotor is actually rotating. A magnet mounted on the periphery of the rotor activates a pulse sensor once per revolution. If, for instance, the belt breaks the pulses cease and an alarm is given. It takes approximately 4 rotor revolutions to activate the alarm. The magnet and the sensor are ordered separately.

The rotation monitor only monitors the system during continuous operation.

1.2.4 Alarm output

Relay with change-over contact. The relay changes over when the rotation monitor activates the alarm, in the event of a network power failure and in the event of an overload.

NOTE: The relay does not switch in the event of Pre alarm Overload.

1.2.5 Operation indication

Two LEDs indicate operation status, see table and description in section 2.3, page 15.

1.2.6 Speed control

It is possible to choose the type of speed control via dip-switches:

Continuous operation

In continuous operation the speed is varied continuously from maximum revs down to 1/25 of the maximum speed (0.4 –10 rpm at 10 rpm maximum).

Continuous operation and intermittent operation in the event of low control signal

This operation status continuously provides operation down to maximum 1/15 of the maximum speed, at lower speeds intermittent operation applies. Cyclic time 40 seconds. Intermittent operation from 1/15 down to 1/50. Total average speed range 0.2 – 10 at 10 max.

1.2.7 The drive system's operating conditions at different control signals

The drive system has an integrated linearisation function that provides a linear function between the control signal and the rotor's efficiency, instead of the speed being proportional to the control signal. This provides good conditions for stable temperature control.

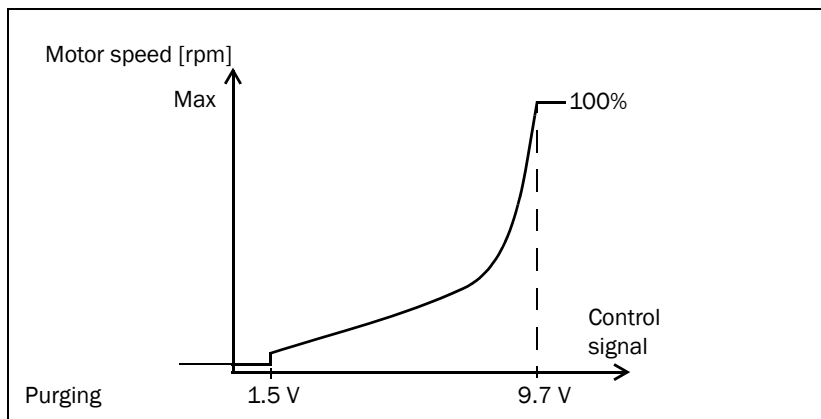

Control signal	Purging	Max. speed (RPM)
0-10 V	1.5 V	9.7 V
2-10 V	3.2 V	9.8 V
4-20 mA	6.4 mA	19.5 mA
0-20 mA	3 mA	19.4 mA

2. Installation instructions

2.1 Installing

Both the motor and the control unit must be installed inside the heat exchanger housing.

2.1.1 Installing the rotation monitor

The magnet for the pulse sensor (the rotation monitor) is attached with screws to the periphery of the heat exchanger. If the housing around the rotor is magnetically conducting, the magnet must be isolated from the housing. The pulse sensor is installed so that the magnet passes it at a distance of 5 to 8 mm; see illustration. The rotation monitor can be ordered separately.

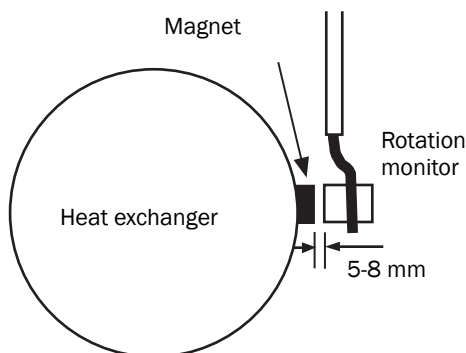

Fig. 1 Rotation monitor

2.2 Wiring instructions



WARNING! The control unit is not protected against short circuits between the wires of the motor cable or against earth faults between the motor cables and earth (ground). A short circuit may totally destroy the control unit. Before switching on the power, always use an ohmmeter to check that there are no short circuits.

An external 10 A fuse must always be fitted. A safety switch must be installed between the mains and the control unit. When the mains power is switched off, a power failure alarm is given.

NOTE! The control unit does not require adjustment.

2.2.1 Tachometer signal

A motor with gear and tachometer from Panasonic or Oriental Motor are intended to be connected to the control unit, with outputs of 25 or 40 W (max 0.7A). For other motor manufacturers or motor outputs contact the control unit supplier or Emotron AB.

The signal level from the motor tachometer varies from one motor supplier to another. The tachometer signal is suitable for DIP switch 1. Regulation is intended for 4-pole motors and only 1 phase capacitor motors can be used. The tachometer must produce 12 pulses per motor revolution and be of the 12 or 24 volt type.

2.2.2 Setting DIP switches

Tachometer signal		Control signal			
12 V	ON OFF		0-10 V	ON OFF	
	24 V	ON OFF		2-10 V	ON OFF
			4-20 mA	ON OFF	
			0-20 mA	ON OFF	
Rotation monitor		Operation			
Rotation monitor activated	ON OFF		Continuous	ON OFF	
No rotation monitor	ON OFF		Continuous and intermittent	ON OFF	

Table 1 Operation with different control signals

Control signal	Purging	From min. to max rpm	Max. rpm
0-10 V	0-1.5 V	1.5-9.7 V	>9.7 V
2-10 V	0-3.2 V	3.2-9.8 V	>9.8 V
4-20 mA	0-6.4 mA	6.4-19.5 mA	>19.5 mA
0-20 mA	0-3 mA	3-19.4 mA	>19.4 mA

2.2.3 Manual control with 10 kOhm potentiometer

The drive system can easily be controlled manually with a 10 kΩ potentiometer connected as follows:

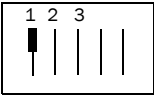
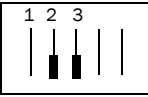
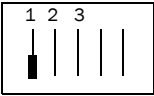
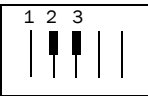
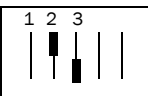
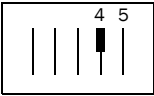
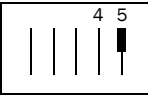
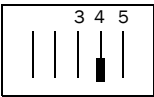
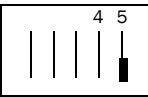
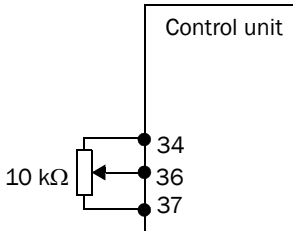

Fig. 2 10 kOhm potentiometer

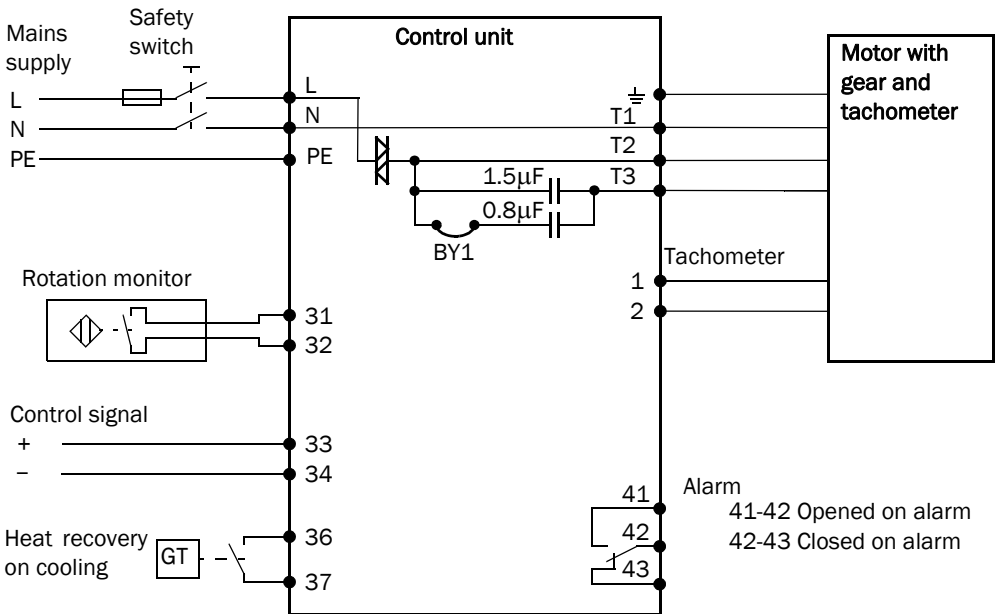

Fig. 3 Wiring diagram

2.2.4 Motor capacitor

Bridge BY1 at the motor terminal controls the size of the motor capacitor that is connected to terminal T3. Cut the link for a capacitor value of 1.5 μF . If the link is left uncut, a capacitance of 2.3 μF (1.5 μF + 0.8 μF) is connected to T3.

An external capacitor can be used instead of the built-in capacitors. The external capacitor is connected according to Fig. 4. Motor terminal T3 is not used when an external motor capacitor is connected.

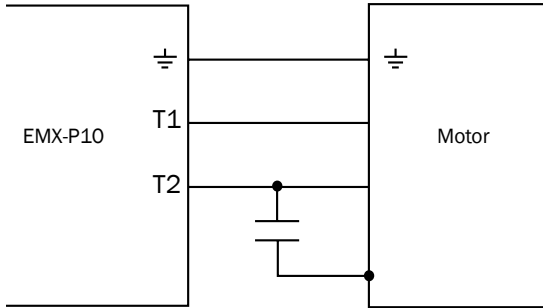

Fig. 4

2.2.5 Recommendations for EMC (electromagnetic compatibility)

In order to meet the requirements of European EMC Directive 89/336/ECC, it is important to observe the following instructions:

- Both motor and control unit shall be installed inside the heat exchanger housing.
- The earth wire in the mains cable is connected to the control unit's ground terminal.
- Check that the heat exchanger's metal casing is grounded separately, not via the mains cable.
- The motor must be grounded in the control unit.

EMX-P10 has a built-in EMC filter. Screened cable does not need to be used.

2.2.6 Heat recovery on cooling

A difference thermostat for heat recovery on cooling (max rpm) can be connected between terminals 36 and 37; see wiring diagram.

2.2.7 Direction of rotation

To change the direction of rotation when the built-in motor capacitor is used, reverse the motor cables at terminals T2 and T3. When an external motor capacitor is used, swap the cable that is connected to T2 with the cable that is connected only to the motor capacitor.

2.2.8 Connection of the motor

It is possible to establish whether the motor is connected or not by taking readings on the motor windings/terminals, see Fig. 5. Take readings between T1 – T2, T1 – T3 and T2 – T3. The resistance between T2 – T3 should be twice that of the two first readings. Applies to Panasonic and Oriental Motor. There may be other versions.

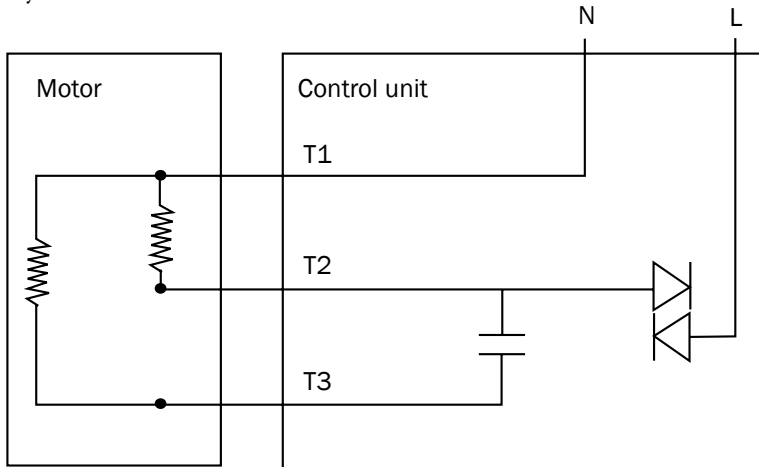

Fig. 5

2.3 Operating status indication

Two LEDs indicate operating status. Both LEDs light up briefly when the power is switched on.

Table 2 *Operating status indication by LEDs.*

Green	Red	Indication	External alarm with alarm relay	Restart
Lights for 2 seconds	Lights for 2 seconds	Power on		
Flashes slowly	Off	Purging operation		
Flashes fast	Off	Continuous operation		
Lights for 2 seconds	Off	The magnet passes the rotation sensor		
Flashes fast	Constantly lit	Pre alarm, overload	No	Automatically restarts 3 times, cooling time 40 min
Off	Flashes fast	Rotation alarm	Yes	Manual, switch on and off the supply voltage
Off	Constantly lit	Overload alarm	Yes	

3. Maintenance and troubleshooting

3.1 Maintenance

The control unit is usually maintenance free. However, you should regularly check wiring and terminals and also check that the control unit is properly installed.

3.2 Troubleshooting

Ensure that the installation has been correctly carried out, e.g. check all cable terminals, check that the cables are properly stripped and that the DIP switches are correctly set.

Table 3 Troubleshooting

Observation/ indication	Cause/action
No LED is lit	Check that there is 230 VAC $\pm 10\%$ at the mains terminal block. If the mains voltage is correct, replace the control unit.
Green LED flashing slowly/ purging operation - low control signal	Are + and - reversed? Are DIP switches 2-3 correctly set? Vary the control signal between min and max. Can 0-10 V (2-10 V) be measured between 33 (+) and 34 (-)? Check EMX-P10 by linking 36-37. The motor should now run up to max rpm.
Red LED is flashing/the rotation monitor is giving an alarm - the motor is still running.	The rotation monitor has detected that input 31-32 has not been closed the last 4 rotor revolutions. This may be due to: <ul style="list-style-type: none">Faulty rotation monitor. The rotation monitor can be checked with the aid of the green LED. First reset the alarm by switching the mains supply to the control unit off and on again. The LED gives a steady light for about 2 seconds when 31-32 is closed, e.g. when the magnet passes the impulse sensor.Faulty control unit. First reset the alarm by switching the mains supply to the control unit off and on again. Link 36-37. Is the voltage between terminals T1 and T2 about 180-230 VAC ? If not, replace the control unit.

Table 3 Troubleshooting

Observation/ indication	Cause/action
Red LED lights constantly and green is off	The motor protector has tripped. Check that the correct motor is connected, that jumper BY1 has been cut if the required value of the motor capacitor is 1.5 μ F and that the heat exchanger is not binding. Also check that the tachometer cable is correctly connected and is not damaged.
The motor runs intermittently	See section 1.2.6, page 6 about continuous and intermittent operation.
The rotation monitor does not give an alarm.	Check DIP switch 4. Also check sensors/magnets.
The motor rotates in the wrong direction	Swap the motor cables in terminals T2 and T3 with each other when using the integrated capacitor. When the external motor capacitor is used the cable connected to T2 is switched with the one that is only connected to the motor capacitor. Also see section 2.2.2, page 11.
The motor runs at full speed even when the control signal is low	Check the integrated tachometer in the motor as well as the wiring for the tachometer.
Motor does not run smoothly, jerky	Check that the capacitance value is correct for the motor being used. See section 2.2.4, page 13 and Fig. 3.

3.3 On replacement

When the control unit is replaced, the entire enclosure with circuit boards must be replaced.

4. Technical data

Table 4 Data

Output data	Purging operation	Built-in function
	Soft start/soft stop	Built-in function
	Alarm output	Changeover contact, max 5A, 230 VAC, AC1
	Motor	Terminal for motor with gear and tachometer, also see section 2.2, page 10.
Input data	Mains voltage	230 VAC \pm 10%, 50/60 Hz
	Current, max	0.7 A
	Control signal	0-10 V, 2-10 V, 0-20 mA, 4-20 mA, 10k Ω potentiometer
General	Protection class	IP54 in enclosed version, with appropriate glands. IP00 in circuit cardversion
	Weight	0.4 kg, enclosed version
	Dimensions W*H*D	122 * 120 * 55 mm excl. glands*
	Ambient temperature	-30 - +40 °C
	Speed range	1:25 during continuous operation. 1:50 during combination of continuous operation and intermittent operation.
	Article number Product	01-3090-00, enclosed version
	Article number Plate/label	01-1475-01, Front plate in Swedish, English and German
		01-1475-02, Connection label in Swedish, English and German
	EMC, Emission	EN50081-1
EMC, Immunity	EN50082-2	

* The product is supplied without glands.

4.1 Accessories and documentation

Table 5 *Accessories*

Part number	Designation
01-2184-00	Rotation sensor with magnet

Table 6 *Instruction manuals*

Part number	Designation
01-3092-00	Swedish
01-3092-01	English
01-3092-02	German
01-3092-07	Finnish (Only PDF file)

4.2 Dimensions and hole outlines

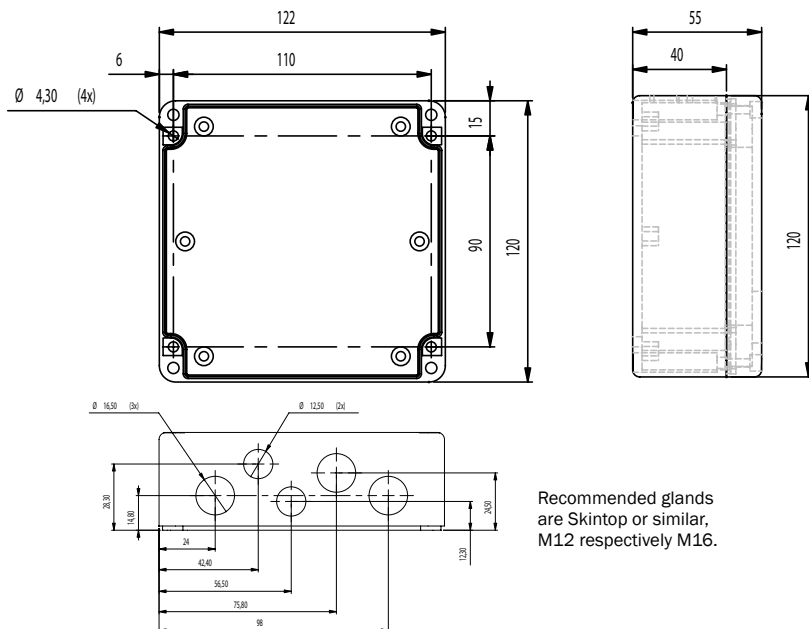

Recommended glands are Skintop or similar, M12 respectively M16.

5. Appendix

Connection label

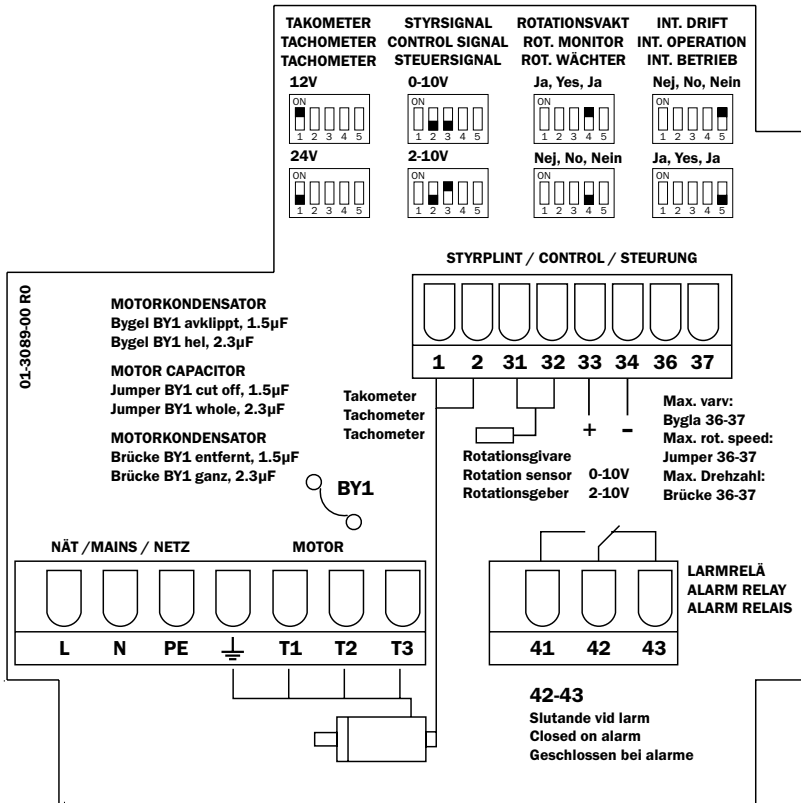

Front panel

EMX-P



● GRÖN GREEN GRÜN

Långsamt blinkande	-	Renblåsningsdrift
Snabbt blinkande	-	Drift
Lyser 1 2 s	-	Magneten passerar rotationsgivaren
Slowly flashing	-	Cleaning operation
Fast flashing	-	Operation
Lit for 2 sec.	-	The magnet passes the rotation sensor
Langsam blinkend	-	Intervallbetrieb
Schnell blinkend	-	Betrieb
Leuchtet 2 Sek. lang	-	Rotormagnet passiert Rotationsgeber

● RÖD RED ROT

Blinkande	-	Rotationsalarm
Lyser	-	Överlast
Flashing	-	Rotation alarm
Lit	-	Overload
Blinkend	-	Rotationsalarm
Leuchtet	-	Überlast

⚡ **WARNING! WARNING! ACHTUNG!**
Bryt spänningen innan locket öppnas
Turn off supply before removing cover
Gerät vor dem Öffnen vom Netz trennen

e m o t r o n



DEDICATED DRIVE

Emotron AB, Mörsaregatan 12, SE-250 24 Helsingborg, Sweden

Tel: +46 42 16 99 00, Fax: +46 42 16 99 49

E-mail: info@emotron.se

Internet: www.emotron.com