

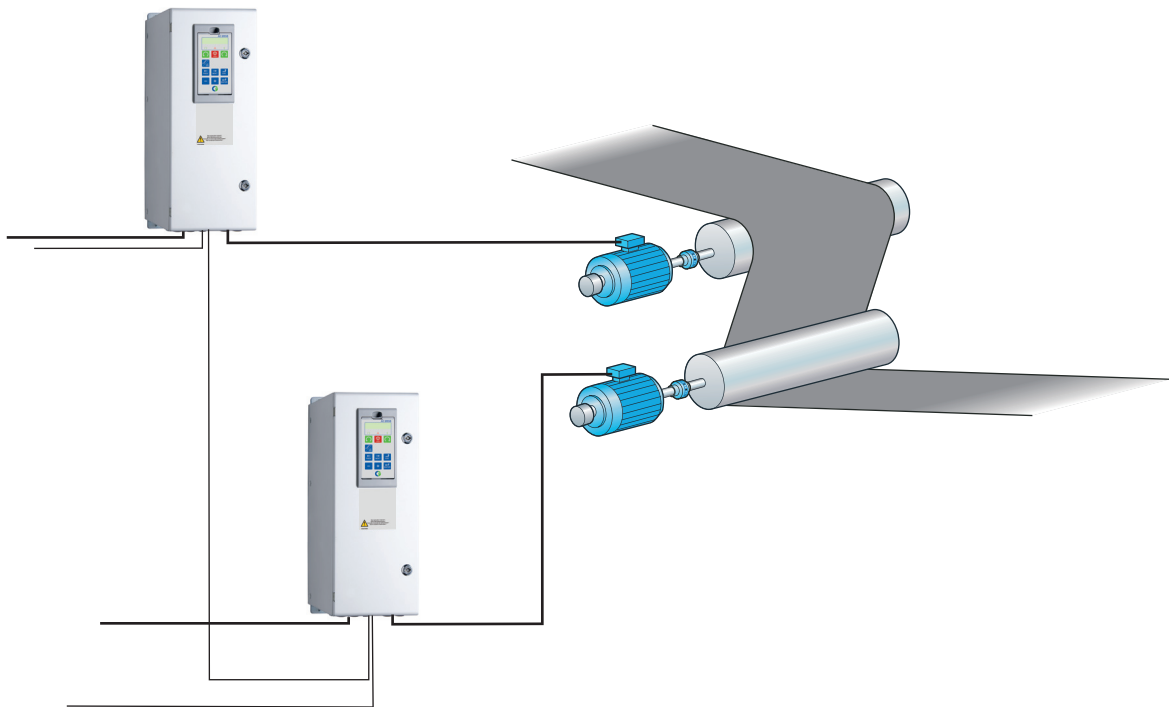

Emotron AC drive Master-follower functionality



Technical note
English

Contents

Master-follower function	3
General	3
Installation	3
Parameter setup	5

Master-follower communication in Emotron AC drive

Technical note - English

Document number: 01-5298-01

Edition: r0

Date of release: 2018-01-30

© Copyright CG Drives & Automation 2018.

CG Drives & Automation retains the right to change specifications and illustrations in the text, without prior notification. The contents of this document may not be copied without the explicit permission of CG Drives & Automation.

1. Master-follower function

1.1 General

The Master-follower functions are designed for coordinated operation of two or more Emotron AC Drives. For example machinery where the motorshafts are coupled to each other via gearing, chain, belt etc. One of the AC drives operates as master to the other drives.

Typical applications are conveyors, hoists, winders, wagon turners etc.

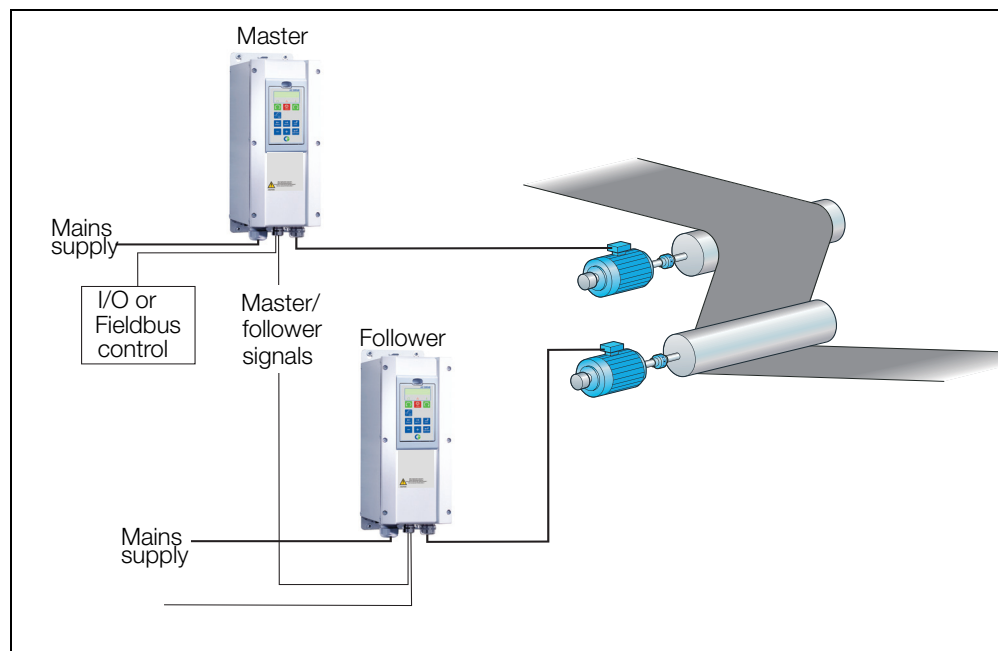

Fig. 1 Master-follower principle.

External control signals are connected to Master. The Master controls the follower reference.

The Master is normally speed controlled and the follower follows the Master torque or speed reference.

In general:

Torque control (load sharing)- is typically used when the motor shafts of the Master and the follower drives are coupled solidly to each other by gearing, chain etc. so that no speed difference between the motor shafts is possible.

Speed control - is typically used when the motor shafts are coupled flexibly to each other so that a slight speed difference is possible. Speed control can also be used on two or more separate conveyors that shall run simultaneously with same speed.

1.2 Installation

This technical note is to be seen as a supplement to the instruction manual for Emotron AC drives.



WARNING!

Before installation, always switch off the mains voltage and wait at least 7 minutes to allow the DC capacitors to discharge before connecting the control signals or changing position of any switches. If the option External supply is used, switch of the mains to the option.

Control signal connections for Master-Follower function

The terminal strips for connecting control signals are accessible after opening the front panel of the AC drives.

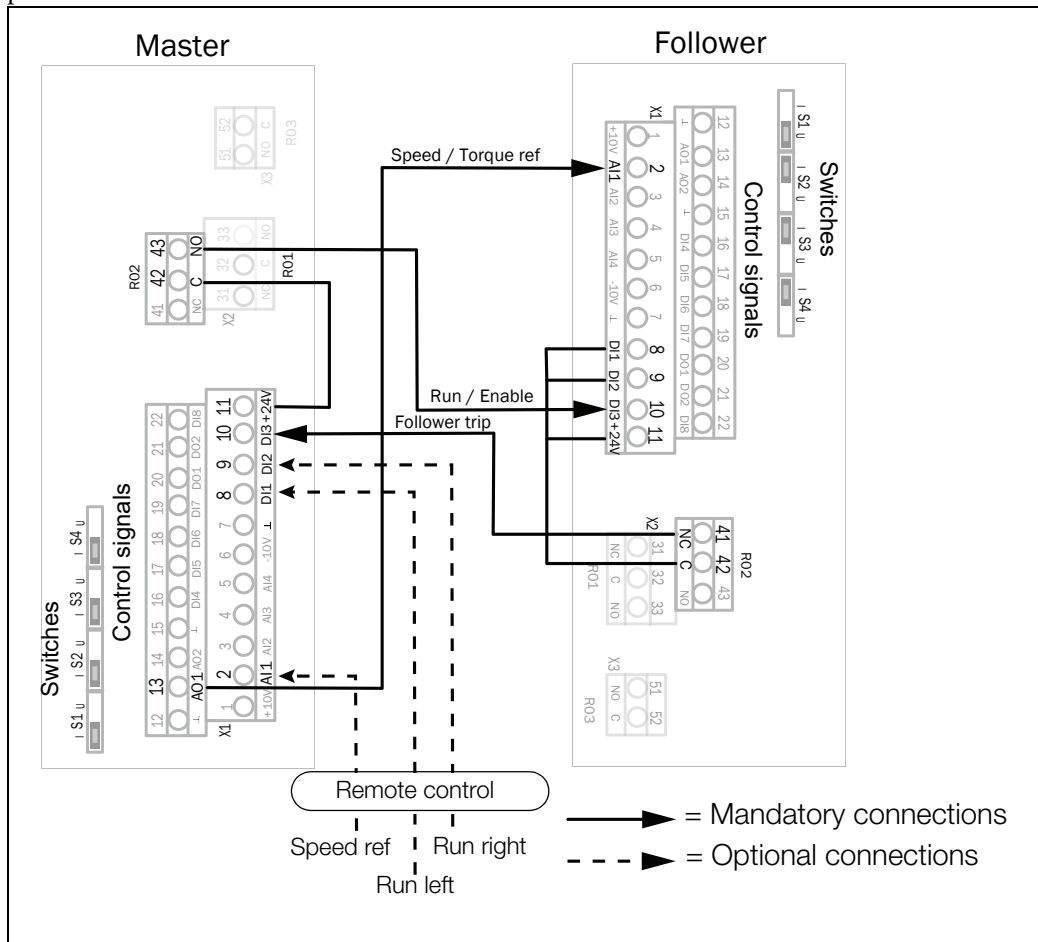

Fig. 2 AC drive control boards with control signal terminal strips

Master			Follower		
Terminal	Name	Function	Terminal	Name	Function
Outputs					
11	+24V	+24V VDC supply voltage	11	+24V	+24V VDC supply voltage
13	AnOut 1	Speed reference			
Digital inputs					
8	DigIn 1	Run left	8	DigIn 1	Run left (jumpered On)
9	DigIn 2	Run Right	9	DigIn 2	Run Right (jumpered On)
10	DigIn 3	Ext trip	10	DigIn 3	Enable
Analogue inputs					
2	AnIn 1	Speed reference from remote	2	AnIn 1	Speed reference from Master
Relay outputs					
42	Com 2	Run, active when the drive is started.	41	N/C 2	Trip
43	N/O 2		42	Com 2	



CAUTION!

Connect all external signals only to the Master drive.
Never try to control the Follower drive by the built in control panel, preferably remove the control panel from the Follower.

1.3 Parameter setup

Parameter setting for Torque mode (load sharing)

Perform these settings to run the follower in Torque mode with torque reference from the Master via AnIn/AnOut where the sign of analogue value gives the torque direction and the Follower run/stop control is given by using Enable input connected from the Master Run output signal. Only available with Emotron VFX2.0 drives

Parameter	Master	Follower	Comment
213 Drive mode	Speed	Torque	
214 Ref Control	---	Remote	
215 Run/Stop Ctrl	---	Remote or Comm	Both control bits RunL & Run R always active if Comm selected
22x Motor Data	---	= Master	
321 Proc Source	Speed	Torque	
339 Start Mode	---	Equal to Master	
33C Brk Release	---	0 s	Any mechanical brake should be handled by Master only (due to StopMode in Torque).
33E Brk Engage	---	0 s	
33F Brk Wait	---	0 s	
343 Max Speed	---	Equal to Master	Set MaxSpeed = 110% of max operating speed ref.
351 Max Torque	---	Equal to Master	
37x Spd Ctrl PI	---	Equal to Master	
3Ax Crane Option	---	Off	If CRIO is used
511 AnIn1 Fc	---	Process Ref	
512 AnIn1 Setup	---	User Bipol V	
5133 AnIn 1 Bipol	---	10.00V	
5136 AnIn1 FcMax	---	Max	
5138 AnIn1 Oper	---	Add +	
5139 AnIn1 Filt	---	0.001s	Set Minimum filter time in Follower
513A AnIn1 Enabl	---	On	
521 DigIn1	---	RunL	Follower jumpered to +24V if [215] = Remote
522 DigIn2	---	RunR	Follower jumpered to +24V if [215] = Remote
523 DigIn3	Ext Trip	Enable	
531 AnOut1 Fc	Torque Ref	---	
532 AnOut1 Setup	User Bipol V	---	
5333 AnOut1 Bipol	10.00V	---	

Parameter	Master	Follower	Comment
5336 AnOut1 FcMax	Max	---	
533 Relay2	Run	Trip	

--- = Setting selectable by user

NOTE: If very high dynamic requirement, please contact CG Drives & Automation for Follower analogue filter change. (control board, part number:01-2942-56)

Parameter setting for speed mode (speed follower)

Available with both Emotron FDU2.0 and VFX2.0 drives

Parameter	Master	Follower	Comment
213 Drive mode	Speed	Speed	
214 Ref Control	---	Remote	
215 Run/Stp Ctrl	---	Remote or Comm	Both control bits RunL & Run R always active if Comm selected
321 Proc Source	Speed	Speed	
331 Acceleration time	---	Equal to Master	Set Follower value lower than Master
332 Deceleration time	---	Equal to Master	Set Follower value lower than Master
339 Start Mode	---	Equal to Master	
343 Max Speed	---	Equal to Master	
351 Max Torque	---	Equal to Master	
37x Spd Ctrl PI	---	Equal to Master	
511 AnIn1 Fc	---	Process Ref	
512 AnIn1 Setup	---	User Bipol V	
5133 AnIn 1 Bipol	---	10.00V	
5136 AnIn1 FcMax	---	Max	
5138 AnIn1 Oper	---	Add +	
5139 AnIn1 Filt	---	0.001s	Set Minimum filter time in Follower
513A AnIn1 Enabl	---	On	
521 DigiIn1	---	RunL	Follower jumpered to +24V if [215] = Remote
522 DigiIn2	---	RunR	Follower jumpered to +24V if [215] = Remote
523 DigiIn3	Ext Trip	Enable	
531 AnOut1 Fc	Speed Ref	---	
532 AnOut1 Setup	User Bipol V	---	
5333 AnOut1 Bipol	10.00V	---	

Parameter	Master	Follower	Comment
5336 AnOut1 FcMax	Max	---	
533 Relay2	Run	Trip	

--- = Setting selectable by user

CG Drives & Automation

Mörsaregatan 12

Box 222 25

SE-250 24 Helsingborg

Sweden

T +46 42 16 99 00

F +46 42 16 99 49

www.cgglobal.com / www.emotron.com