



# Emotron FlowDrive

## Waste water pumping AC drive

Emotron FLD48-2p5-2Y to 038-2Y  
0.75 - 18.5 kW



Installation & Getting started instruction





## **Emotron Flowdrive Emotron FLD48-2P5-2Y to -38-2Y 0.75 - 18.5 kW,**

Installation and getting started instruction

Document number: 01-6143-01

Edition: r2

Date of release: 26 March 2018

© Copyright CG Drives & Automation Sweden AB 2015 - 2018

CG Drives & Automation Sweden AB retains the right to change specifications and illustrations in the text, without prior notification.

The contents of this document may not be copied without the explicit permission of CG Drives & Automation Sweden AB.

# Installation & Getting started

---

## Contents

<b>Contents</b> .....	<b>1</b>
<b>Safety Instructions</b> .....	<b>5</b>
<b>1. General</b> .....	<b>8</b>
1.1 Delivery and unpacking .....	9
1.2 Warranty .....	9
1.3 Using of the instruction manual .....	9
1.4 Model Explanation.....	9
1.4.1 Model Type code number .....	10
<b>2. Electrical specifications</b> .....	<b>12</b>
2.1 Electrical specifications related to model .....	14
2.2 Brake resistor .....	15
2.3 Fuses and input current.....	16
2.3.1 According to IEC ratings .....	16
2.4 Mounting.....	17
2.4.1 Cooling /cabinet mounting .....	17
2.5 Remove dust cover .....	19
2.6 Remove Keypad and Cover .....	20
2.6.1 Remove the keypad .....	20
2.6.2 Open the Cover.....	20
<b>3. Cable connections</b> .....	<b>22</b>
3.1 Mains and motor cables.....	22
3.1.1 Cable connection data for mains, motor and PE cables according to IEC ratings.....	22
3.1.2 Mains and motor cables connection.....	22
3.2 Connecting the Control Signals .....	26
3.2.1 Cables .....	26
3.2.2 Terminal connections .....	28
3.3 Inputs configuration with the jumpers .....	30
3.4 Connect minimum wiring.....	31
3.4.1 Full wiring examples .....	35

# Installation & Getting started

---

<b>4.</b>	<b>Mount the cover.....</b>	<b>38</b>
4.1	Mount the keypad .....	39
<b>5.</b>	<b>Getting started.....</b>	<b>40</b>
5.1	Control panel .....	41
5.1.1	The display.....	41
5.1.2	Indications on the display .....	43
5.1.3	LED indicators.....	44
5.2	Function keys.....	45
5.2.1	Using the function keys .....	46
5.2.2	Toggle loop.....	47
5.3	Basic configuration (all AC drives).....	48
5.3.1	Switch on the mains.....	48
5.3.2	Language and supply voltage.....	48
5.3.3	Set FlowDrive configuration .....	49
5.4	Standalone / Master configuration.....	50
5.4.1	Set the Motor Data.....	50
5.4.2	Minimum frequency.....	50
5.4.3	Level sensor configuration.....	51
5.4.4	Set sump levels.....	51
5.4.5	Set reservoir geometry .....	52
5.4.6	Overflow level switch runtime .....	56
5.5	Copy to follower .....	56
5.6	Test run.....	56
5.7	Engage “Auto Tune” program to optimize energy consumption....	57
5.8	Configuration of additional features (optional) .....	59
5.8.1	Flush start .....	59
5.8.2	Random start level .....	59
5.8.3	Pump cleaning .....	59
5.8.4	Sump cleaning .....	60
5.8.5	Pipe cleaning.....	60
<b>6.</b>	<b>Options.....</b>	<b>61</b>
6.1	EmoSoftCom .....	61
6.2	I/O Board .....	61
6.3	RS232/485 .....	61
6.4	PTC/RTC .....	62
6.5	Serial communication and fieldbus .....	62

# Installation & Getting started

---

6.6	Standby supply board option .....	63
6.7	Safe Stop option .....	63
6.8	EMC filter class C2.....	67
6.9	Other options .....	67
<b>7.</b>	<b>Menu List.....</b>	<b>68</b>

# Installation & Getting started

---

# Safety Instructions

## Handling the AC drive

Installation, commissioning, demounting, taking measurements, etc. of or on the AC drive may only be carried out by personnel technically qualified for the task.

A number of national, regional and local regulations govern handling, storage and installation of the equipment. Always observe current rules and legislation.

## Opening the AC drive

---



### **WARNING!**

**Always switch off the mains voltage before opening the AC drive and wait at least 10 minutes to allow the capacitors to discharge.**

---

Always take adequate precautions before opening the AC drive. Although the connections for the control signals and the switches are isolated from the main voltage, do not touch the control board when the AC drive is switched on.

## Precautions to be taken with a connected motor

If work must be carried out on a connected motor or on the driven machine, the mains voltage must always be disconnected from the AC drive first. Wait at least 10 minutes before starting work.

## Earthing

The AC drive must always be earthed via the mains safety earth connection.

### Earth leakage current

---



#### CAUTION!

This AC drive has an earth leakage current which does exceed 3.5 mA AC. Therefore the minimum size of the protective earth conductor must comply with the local safety regulations for

high leakage current equipment which means that according to the standard IEC61800-5-1 the protective earth connection must be assured by one of following conditions:

PE conductor cross-sectional area shall for phase cable size  $< 16 \text{ mm}^2$  (6 AWG) be  $>10 \text{ mm}^2$  Cu ( $16 \text{ mm}^2$  Al) or use a second PE conductor with same area as original PE conductor.

For cable size above  $16 \text{ mm}^2$  (6 AWG) but smaller or equal to  $35 \text{ mm}^2$  (2 AWG) the PE conductor cross-sectional area shall be at least  $16 \text{ mm}^2$  (6 AWG).

For cables  $>35 \text{ mm}^2$  (2 AWG) the PE conductor cross-sectional area should be at least 50 % of the used phase conductor.

When the PE conductor in the used cable type is not in accordance with the above mentioned cross-sectional area requirements, a separate PE conductor should be used to establish this.

---

### Residual current device (RCD) compatibility

This product causes a DC current in the protective conductor. Where a residual current device (RCD) is used for protection in case of direct or indirect contact, only a Type B RCD is allowed on the supply side of this product. Use RCD of 300 mA minimum.

### EMC Regulations

In order to comply with the EMC Directive, it is absolutely necessary to follow the installation instructions. All installation descriptions in this manual follow the EMC Directive.

### Voltage tests (Megger)

Do not carry out voltage tests (Megger) on the motor, before all the motor cables have been disconnected from the AC drive.

### Condensation

If the AC drive is moved from a cold (storage) room to a room where it will be installed, condensation can occur. This can result in sensitive components becoming damp. Do not connect the mains voltage until all visible dampness has evaporated.

### Incorrect connection

The AC drive is not protected against incorrect connection of the mains voltage, and in particular against connection of the mains voltage to the motor outlets U, V and W. The AC drive can be damaged in this way.

### Power factor capacitors for improving $\cos\phi$

Remove all capacitors from the motor and the motor outlet.

### Precautions during Autoreset

When the automatic reset is active, the motor will restart automatically provided that the cause of the trip has been removed. If necessary take the appropriate precautions.

### Transport

To avoid damage, keep the AC drive in its original packaging during transport. This packaging is specially designed to absorb shocks during transport.

### IT Mains supply

The AC drives can be modified for an IT mains supply, (non-earthed neutral), please contact your supplier for details.

### Alarms

Never disregard an alarm. Always check and remedy the cause of an alarm.

### DC-link residual voltage

---



#### **WARNING!**

After switching off the mains supply, dangerous voltage can still be present in the AC drive. When opening the AC drive for installing and/or commissioning activities, wait at least 10 minutes. In case of malfunction a qualified technician should check the DC-link or wait for one hour before dismantling the AC drive for repair.

---

# 1. General

Congratulations for choosing a product from CG Drives & Automation!

This is a Quick Start Guide providing brief information about how to install this AC drive and how to get started.

Before you start mounting and installation, please read and consider the Safety chapter first.

The software instruction manual you will find in the file archive on [www.emotron.com](http://www.emotron.com). In the software instruction manual you will find detailed information for setting up and running this AC drive.

Instruction manuals for optional boards are also found in the file archive.

All documentation is available on [www.emotron.com](http://www.emotron.com).

Emotron FlowDrive is an AC drive dedicated for controlling wastewater pumps with focus on continuous pumping with best economy (lowest cost).

FlowDrive can operate as a Standalone unit (1 drive) or in a Master-Follower configuration (2 drives).

## Prerequisites

In order to utilize the FlowDrive, following is required:

- Analogue water level sensor for automatic level control, preferably 4-20mA. Level value can be sent via communication. Level sensor doesn't have to be connected
- Master-Follower control cable (only required in a Master-Follower configuration)
- One switch per drive for manual control; Auto- Off - Manual run (optional but highly recommended)
- Digital switch for redundant overflow detection (optional, can be disabled)
- 1 pump per drive (if dual pumps are used, equal pump performance is required)

Several options are available, listed in chapter 7. page 53, that enable you to customize the AC drive for your specific needs.

---

**NOTE: Read this instruction manual carefully before starting installation, connection or working with the AC drive.**

---

### 1.1 Delivery and unpacking

Check for any visible signs of damage. Inform your supplier immediately of any damage found. Do not install the AC drive if damage is found.

Check that all items are present and that the type number is correct.

### 1.2 Warranty

The warranty applies when the equipment is installed, operated and maintained according to instructions in this instruction manual. Duration of warranty as per contract.

Faults that arise due to faulty installation or operation are not covered by the warranty.

### 1.3 Using of the instruction manual

Within this instruction manual the abbreviation “AC drive” is used to indicate the complete variable speed drive as a single unit.

### 1.4 Model Explanation

The Model shown on product label indicates the series name, applicable type of power supply, power class and hardware, etc. via the combination of numbers, symbols and letters.

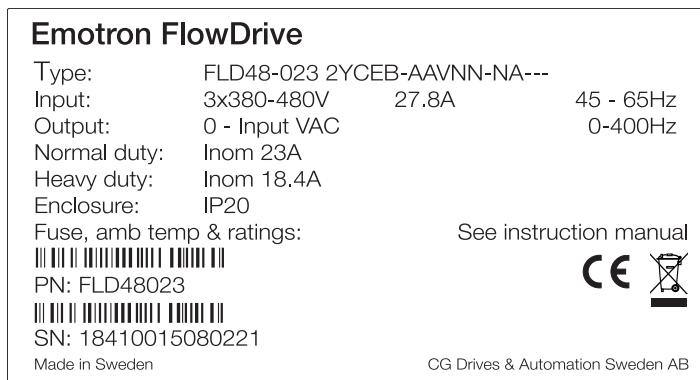

*Fig. 1 Product label*

## 1.4.1 Model Type code number

Fig. 2 gives an example of the type code numbering used on all AC drives. With this code number the exact type of the drive can be determined. This identification will be required for type specific information when mounting and installing. The code number is located on the product label, on the AC drive see Fig. 1.

Type code	FLD	48	-023	-2Y	C	E	B	-	A	A	V	N	N	-	N	A	-	-	-
Position No	1	2	3	4	5	6	7	8	9	10	11	12	13	14	15	16	17	18	19

Fig. 2 Type code number

Table 1 Type code explanation

Position	Configuration	
1	AC drive type	FLD
2	Supply voltage	48=480 V mains
3	Rated current (A) continuous	-2P5=2.5 A - -038=38 A
4	Protection class	2Y=IP20
5	Control panel	C=Standard panel
6	EMC option	E=Standard EMC (2 <sup>nd</sup> Environment, Category C3) I=IT-Net
7	Brake chopper option	B=Chopper built in, standard
8		--=Not used
9	Brand label	A=Standard
10	Painted AC drive	A=Standard paint
11	Coated boards, option	V=Coated boards, standard
12	Option position 1	N=No option I=Extended I/O- 2Y (micro) max2 T=PTC & RTC-2Y (micro), max 1 S=Safe Stop-2Y (micro), max 1 R=RS232/485-2Y (micro), max 1
13	Option position 2	

Table 1 Type code explanation

Position	Configuration	
14		-- Not used
15	Option position, communication	N=No option D=DeviceNet P=Profibus S=RS232/485 M=Modbus/TCP F=Modbus/TCP 2-port, M12 E= EtherCAT A=Profinet IO 1-port B=Profinet IO 2-port G=EtherNet/IP 2-port
16	Software type	A= Standard software, Language set 1 I = Std sw Language set 2 See menu "Language [211]" in separate Software instruction.
17		-- Not used
18		-- Not used
19	Approval/certification	--CE approved

## 2. Electrical specifications

General	
Mains voltage:	3 phase 230 - 480 V +10/-15 % (-10 % at 230 V)
Mains frequency:	45 to 65 Hz
Input power factor:	0.7 - 0.8
Output voltage:	0-Mains supply voltage:
Output frequency:	0-400 Hz
Output switching frequency:	3 kHz, adjustable 1,5-6 kHz
Efficiency at nominal load:	≥93 % for frame sizes A3 and B3 ≥95 % for frame size C3
Control signal inputs: Analogue (differential)	
Analogue Voltage/current:	0±10 V/0-20 mA via switch
Max. input voltage:	+30 V/30 mA
Input impedance:	20 kOhm (voltage) 250 kOhm (current)
Resolution:	11 bits + sign
Hardware accuracy:	1% type + 1 ½ LSB fsd
Non-linearity	1½ LSB
Digital:	
Input voltage:	High: >9 VDC, Low: <4 VDC
Max. input voltage:	+30 VDC
Input impedance:	<3.3 VDC: 4.7 kOhm ≥3.3 VDC: 3.6 kOhm
Signal delay:	≤8 ms
Control signal outputs: Analogue	
Output voltage/current:	0-10 V/0-20 mA via software setting
Max. output voltage:	+15 V @5 mA cont.
Short-circuit current (∞):	+15 mA (voltage), +140 mA (current)
Output impedance:	10 Ohm (voltage)
Resolution:	10 bit
Maximum load impedance for current	500 Ohm
Hardware accuracy:	1.9% type fsd (voltage), 2.4% type fsd (current)
Offset:	3 LSB
Non-linearity:	2 LSB
Digital	
Output voltage:	High: >20 V <sub>DC</sub> @50 mA, >23 V <sub>DC</sub> open Low: <1 V <sub>DC</sub> @50 mA
Shortcircuit current(∞):	100 mA max (together with +24 V <sub>DC</sub> )

<b>Relays</b>	
Contacts	0.1 – 2 A/Umax 250 V <sub>AC</sub> or 42 V <sub>DC</sub>
<b>References</b>	
+10 VDC	+10 V <sub>DC</sub> @10 mA Short-circuit current +30 mA max
-10 VDC	- 10 V <sub>DC</sub> @10 mA
+24 VDC	+24 V <sub>DC</sub> Short-circuit current +100 mA max (together with Digital Outputs)

## 2.1 Electrical specifications related to model

Table 2 Typical motor power at mains voltage 230, 400 and 460 V. AC drive main voltage range 380 - 480 V.

Model	Max. output current [A]*	Normal duty (120%, 1 min every 10 min)					Frame size
		Rated current [A]	Power @ 230 V [kW]	Power @ 230 V [hp]	Power @ 400 V [kW]	Power @ 460 V [hp]	
FLD48-2P5-2Y	3.0	2.5	0.37	0.5	0.75	1	A3
FLD48-3P4-2Y	4.1	3.4	0.55	0.75	1.1	1.5	
FLD48-4P1-2Y	4.9	4.1	0.75	1	1.5	2	
FLD48-5P6-2Y	6.7	5.6	1.1	1.5	2.2	3	
FLD48-7P2-2Y	8.6	7.2	1.1	1.5	3.0	4	
FLD48-9P5-2Y	11.4	9.5	2.2	3	4.0	5	
FLD48-012-2Y	14.4	12	2.2	3	5.5	7.5	B3
FLD48-016-2Y	19.2	16	4.0	5.5	7.5	10	
FLD48-023-2Y	27.6	23	5.5	7.5	11	15	C3
FLD48-032-2Y	37.2	31	7.5	10	15	20	
FLD48-038-2Y	45.6	38	11	15	18.5	25	

\* Available during limited time and as long as allowed by drive temperature.

### 2.2 Brake resistor

These AC drives are as standard equipped with built in Brake chopper and connection for DC+/DC-. The brake resistor must be mounted outside the AC drive.

*Table 3 Minimum resistance depending on drive size and supply voltage.*

Type	Rmin if supply 380–415 V <sub>AC</sub> [Ohm]	Rmin if supply 440–480 V <sub>AC</sub> [Ohm]
FLD48-2P5-2Y	120	150
-3P4-2Y	120	150
-4P1-2Y	120	150
-5P6-2Y	91	120
-7P2-2Y	91	120
-9P5-2Y	68	91
-012-2Y	51	68
-016-2Y	36	51
-023-2Y	27	33
-032-2Y	18	24
-038-2Y	15	20

## 2.3 Fuses and input current

### 2.3.1 According to IEC ratings

Use mains fuses of the type gL/gG conforming to IEC 269 or breakers with similar characteristics. Check the equipment first before installing the glands.

Max. Fuse = maximum fuse value that still protects the AC drive and upholds warranty.

---

**NOTE: The dimensions of fuse and cable cross-section are dependent on the application and must be determined in accordance with local regulations.**

---

Table 4 Fuses and input current

Model	Nominal input current		Maximum value fuse [A]
	with DC Choke [A]	without DC Choke [A]	
FLD48-2P5-2Y	2.0	3.5	10
-3P4-2Y	2.5	4.5	10
-4P1-2Y	2.7	4.7	10
-5P6-2Y	4.5	6.1	16
-7P2-2Y	6.0	9.0	16
-9P5-2Y	8.1	11.0	25
-012-2Y	10.2	15.3	25
-016-2Y	14.0	20.0	32
-023-2Y	20.4	27.8	40
-032-2Y	27.0	37.0	63
-038-2Y	34.0	46.0	63

## 2.4 Mounting

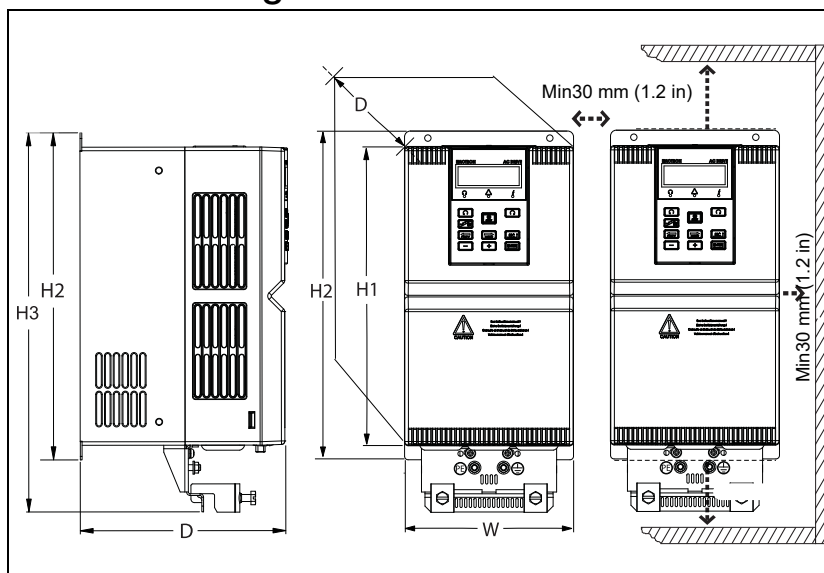

Fig. 3 Dimensions

Table 5 Dimensions

Frame size	Dim. H1/H2/H3 x W x D mm	Dim. H1/H2/H3 x W x D in	Weight kg (lbs)
A3	220/245/287 x 120 x 169	8.7/9.6/11.3 x 4.7 x 6.7	2.6 (5.7)
B3	255/280/325 x 145 x 179	9.8/11/12.8 x 5.7 x 7	3.9 (8.6)
C3	335/365/407 x 190 x 187	13.2/14.4/16 x 7.5 x 7.4	5 (11)

### 2.4.1 Cooling /cabinet mounting

If the AC-drive is installed in a cabinet, the rate of airflow supplied by the cooling fans must be taken into consideration.

Frame size	Emotron AC drive model	Flow rate m <sup>3</sup> /hour
A3	-2P5 to -012	39
B3	-016 to -023	89
C3	-032 to -038	177

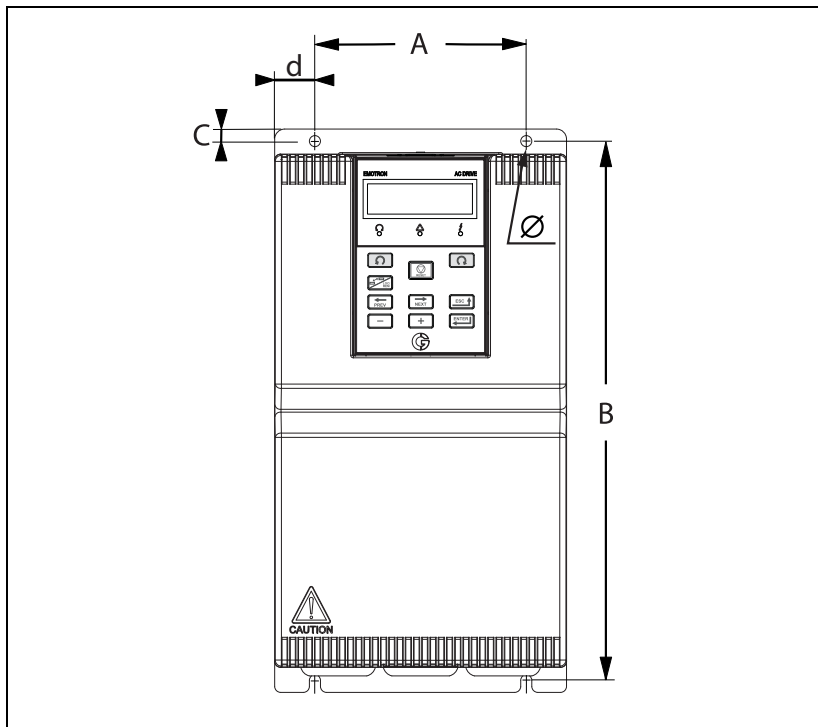

Fig. 4 Mounting dimensions.

Table 6 Mounting dimensions

Frame size	A mm (in)	B mm (in)	C mm (in)	D mm (in)	Ø mm (in)
A3	80 (3.15)	233 (9.17)	6 (0.24)	20 (0.79)	5.5 (0.20)
B3	105 (4.13)	268 (10.55)	6 (0.24)	20 (0.79)	5.5 (0.20)
C3	120 (4.72)	353 (13.89)	6 (0.24)	35 (1.38)	6 (0.24)

## 2.5 Remove dust cover

Remove the dust cover when installing the AC drive in a cabinet, see Fig. 5.

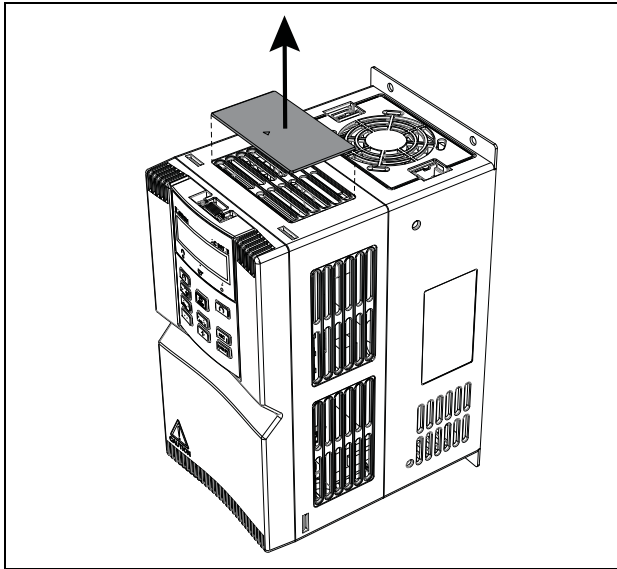

*Fig. 5 Remove the dust cover*

### 2.6 Remove Keypad and Cover

In order not to damage the keypad terminal plug, remove the keypad before you remove the front cover.

#### 2.6.1 Remove the keypad

Press the quick-release latch of keypad as indicated by number "1" in Fig. 6, then pull the keypad out to release as indicated by "2".

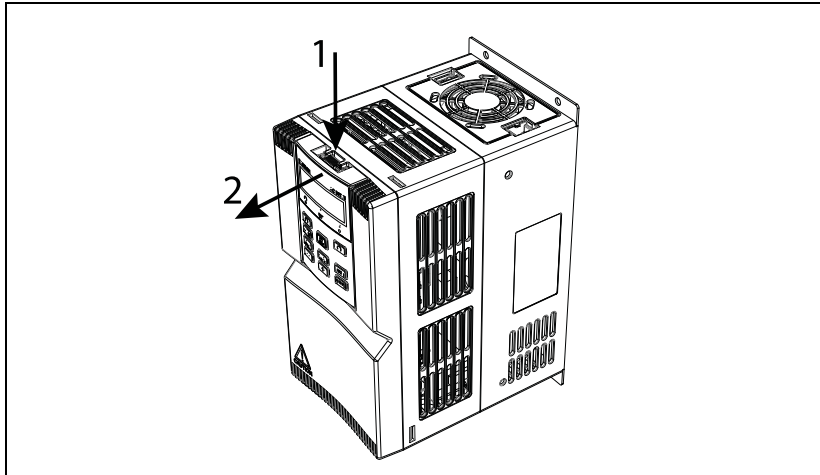

*Fig. 6 Remove the keypad*

#### 2.6.2 Open the Cover

First remove the keypad according to Figure 6.

##### **Frame size A3 and B3**

Use a flat screwdriver to press in the quick-release latches at the bottom of the cover to easily remove the cover, as indicated by "2", pull the cover out to release, as indicated by number "3".

##### **Frame size C3**

Loosen the captive cover screw with your fingers, as indicated by number "1" in Fig. 7 . Then use a flat screwdriver to press in the quick-release latches at the bottom of the cover to easily remove the cover, as indicated by "2", pull the cover out to release, as indicated by number "3".

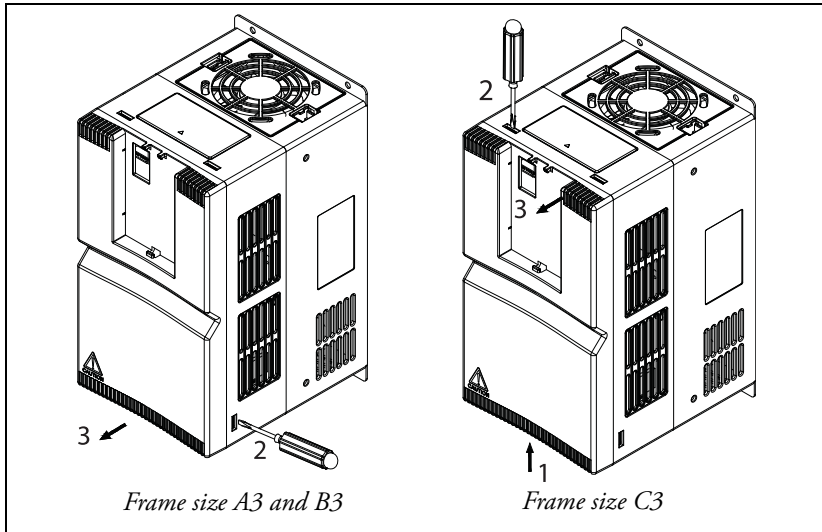

Fig. 7 Open the cover.

### 3. Cable connections

#### 3.1 Mains and motor cables

Dimension the mains and motor cables according to local regulations. The cable must be able to carry the AC drive load current.

##### 3.1.1 Cable connection data for mains, motor and PE cables according to IEC ratings

Table 7 Cable connector range and tightening torque according to IEC ratings.

Model FLD48	Frame size	Cable cross section connector range			Cable type
		Mains, motor, brake and PE			
		Cable area mm <sup>2</sup> /AWG	Screw	Tightening torque Nm /Lb-In	
-2P5-2Y	A3	2.5 / 13	M3.5	0.8/7	Copper (Cu) 75°C
-3P4-2Y					
-4P1-2Y		2.5 / 13	M4	1.4/12	
-5P6-2Y					
-7P2-2Y					
-9P5-2Y					
-012-2Y	4 / 11				
-016-2Y	B3	6 / 9			
-023-2Y					
-032-2Y	C3	6 / 9	M5	2.7/24	
-038-2Y					

##### 3.1.2 Mains and motor cables connection

Connect the mains and motor cables according to Fig. 8. Secure the cables with the EMC/strain relief clamps.

There are two Ferrites included in delivery, one ferrite for Mains wires and the other ferrite for the motor wires.

Lead the PE/earth wires directly to the Earth connection screws (not through the ferrites).

## Installation & Getting started

### Mains cable

- Use one ferrite for Mains wires L1, L2, L3. Wind the wires once around the ferrite. Connect the wires to the terminals R/L1, S/L2 and T/L3.

### Motor cable

- Connect the motor cable screen to the clamp according to Fig. 8.
- Use the other ferrite for the motor wires U, V and W, let the wires go straight through the ferrite. Connect the wires to the terminals U/T1, V/T2 and W/T3.

Secure all other cables such as DC or brake cables with tie wraps by using the slots.

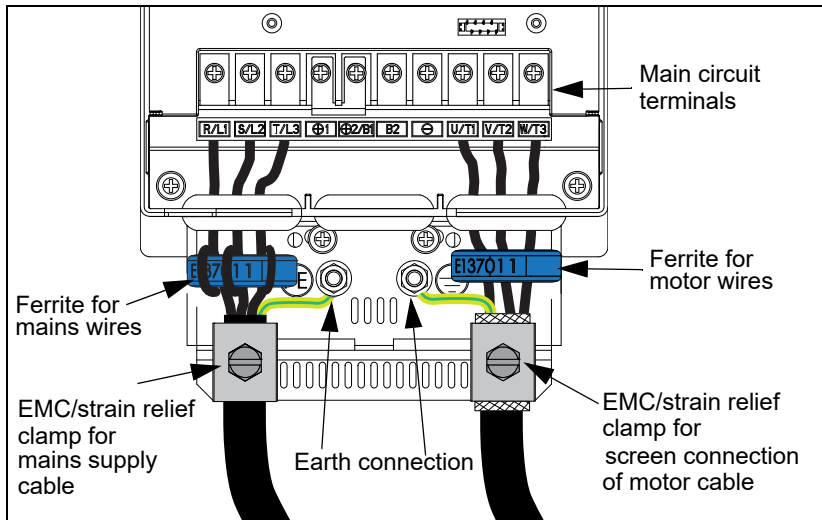

Fig. 8 Mains and motor cable connections

### Main Circuit Terminals

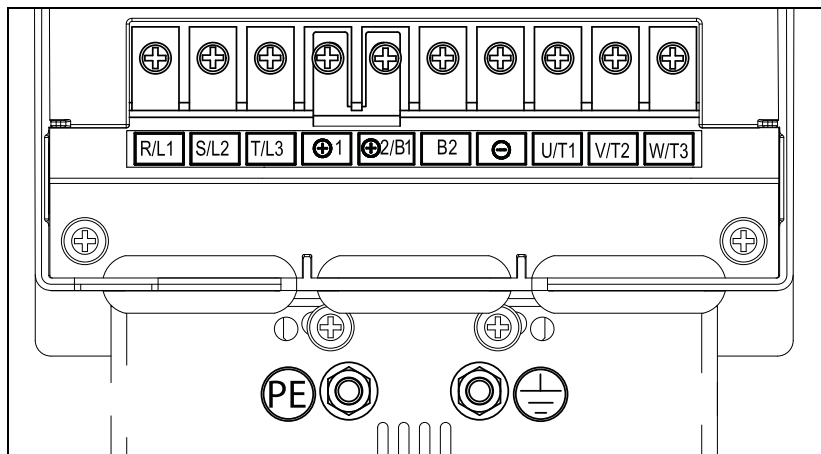
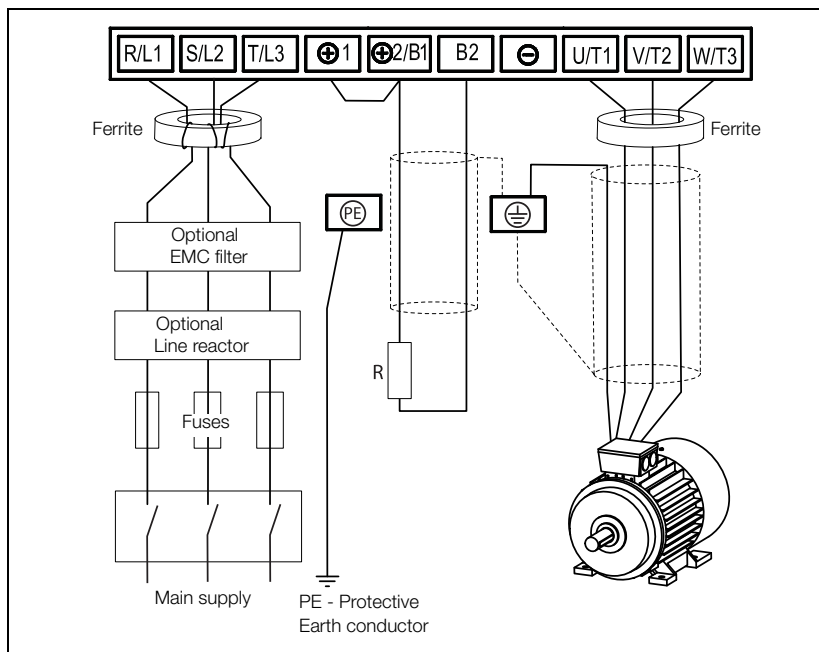

Fig. 9 Main circuit terminals.

Table 8 Terminal markings

Terminal marks	Designation and function of terminals
R/L1, S/L2, T/L3	Three-phase AC input terminals.
⊕1, ⊕2/B1	DC reactor connection terminals. Connected to +2/B1 with a jumper as factory default
⊕2/B1, B2	Braking resistor connection terminals
B2, ⊖	DC input terminals of externally mounted brake unit
⊕1, ⊖	DC power supply input terminals
U/T1, V/T2, W/T3	Three-phase AC output terminals
PE ⊥	Ground terminals, PE



## WARNING!

In order to work safely, the mains earth must be connected to PE and the motor earth to  $\perp$ .

### 3.2 Connecting the Control Signals

#### 3.2.1 Cables

Always use screened control signal cables. The standard control signal connections are suitable for stranded flexible wire up to 1.5 mm<sup>2</sup> (AWG15) and for solid wire up to 2.5 mm<sup>2</sup>(AWG13).

*Table 9 Cable connector range and tightening torque*

Cable cross section connector range mm <sup>2</sup> / AWG	Screw	Tightening torque (Nm/Lb-In)
1.5 - 2.5 / 15-13	M3	0.5 / 4.4

#### Screening

Connect the cable screen to the Earthing screw and secure it with cable ties see Fig. 11.

For all signal cables the best results are obtained if the screen is connected to both ends: the AC drive side and at the source (e.g. PLC, or computer).

It is strongly recommended that the signal cables be allowed to cross mains and motor cables at a 90° angle. Do not let the signal cable go in parallel with the mains and motor cable.

---

**NOTE:** The screening of control signal cables must comply with the immunity levels given in the EMC Directive (reduction of noise level).

---

---

**NOTE:** The control cables must be separated from motor and mains cables.

---

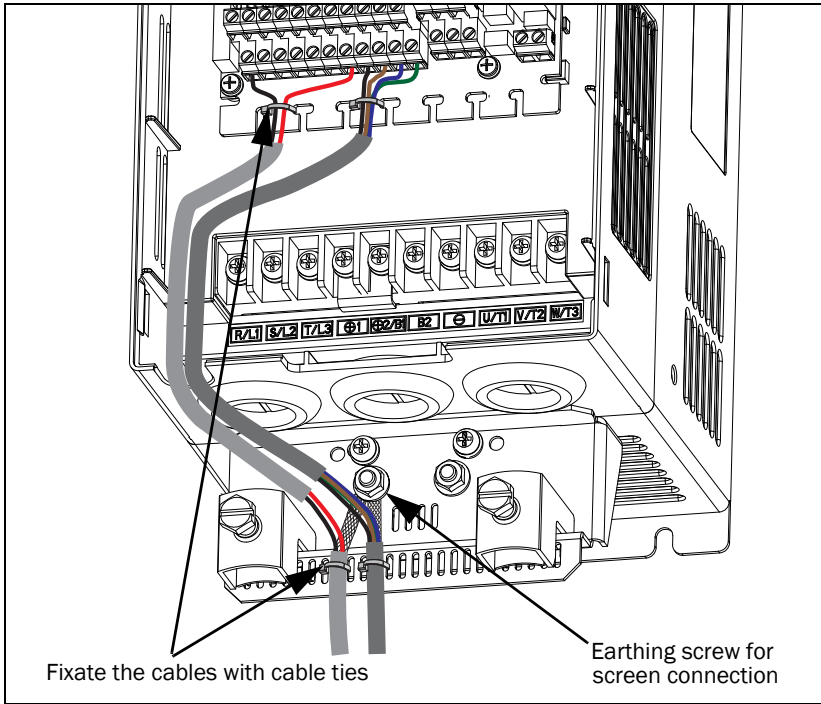

Fig. 11 Connecting the control signals and screen connection.

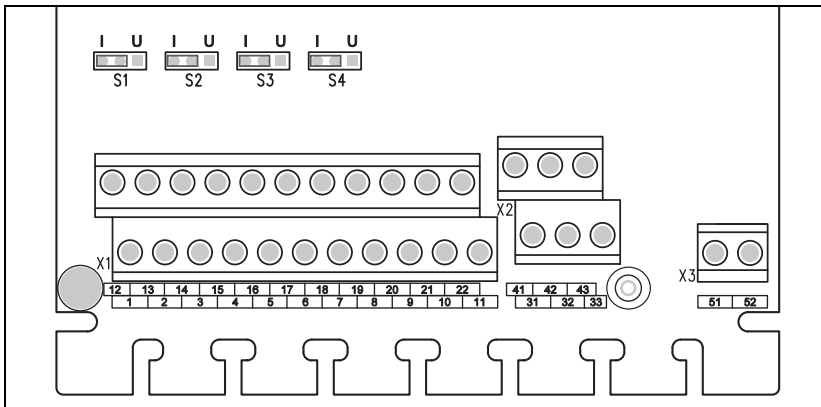

Fig. 12 Terminals for control signal connections and Jumpers S1 - S4,

### 3.2.2 Terminal connections

Table 10 describes the default functions for the signals. The inputs and outputs are programmable for other functions as described in the software instruction manual.

---

**NOTE:** The maximum total combined current for outputs 11, 20 and 21 is 100 mA.

---

---

**NOTE:** It is possible to use external 24 V DC if connection to Common (15).

---

*Table 10 Control signals default functions*

Terminal	Name	Function (Default)
Outputs		
1	+10 V	+ 10 V <sub>DC</sub> supply voltage
6	-10 V	
7	Common	Signal ground
11	+24 V	+24 V <sub>DC</sub> supply voltage
12	Common	
15	Common	
Digital inputs		
8	DigIn 1	Flow ManRun (Forced run)
9	DigIn 2	Flow AutoRun (Auto run)
10	DigIn 3	FlowLinkIn
16	DigIn 4	Off
17	DigIn 5	Off
18	DigIn 6	Overflow level switch (optional)
19	DigIn 7	Off
22	DigIn 8	Reset

## Installation & Getting started

---

Table 10 Control signals default functions

Terminal	Name	Function (Default)
Digital outputs		
20	DigOut 1	
21	DigOut 2	FlowLinkOut
Analogue inputs		
2	AnIn 1	Level sensor
3	AnIn 2	Off
4	AnIn 3	Off
5	AnIn 4	Off
Analogue outputs		
13	AnOut 1	
14	AnOut 2	
Relay outputs		
31	N/C 1	Relay 1 output Trip, active when the AC drive is in a TRIP condition.
32	COM 1	
33	N/O 1	
41	N/C 2	Relay 2 output Run, active when the AC drive is started.
42	COM 2	
43	N/O 2	
51	COM 3	Relay 3 output
52	N/O 3	Off

---

**NOTE:** N/C is opened when the relay is active and N/O is closed when the relay is active.

---



### WARNING!

The relay terminals 31-52 are single isolated. Do NOT mix SELV voltage with e.g. 230 VAC on these terminals. A solution when dealing with mixed SELV/system voltage signals is to install an additional I/O board option ( see chapter 6.2 page 61) and connect all SELV voltage signals to the relay terminals of this option board while connecting all 230VAC signals to the control board relay terminals 31 - 52.

## 3.3 Inputs configuration with the jumpers

The jumpers S1 to S4 are used to set the input configuration for the 4 analogue inputs AnIn1, AnIn2, AnIn3 and AnIn4 as described in table 11. See Fig. 12 for the location of the jumpers.

Table 11 Jumper settings

Input	Signal type	Jumper	
AnIn1	Voltage	S1	
	Current (default)	S1	
AnIn2	Voltage	S2	
	Current (default)	S2	
AnIn3	Voltage	S3	
	Current (default)	S3	
AnIn4	Voltage	S4	
	Current (default)	S4	

### 3.4 Connect minimum wiring

Here you will make up the minimum wiring for starting.

To comply with the EMC standard, use screened control cables with plaited flexible wire up to 1.5 mm<sup>2</sup> (AWG15) or solid wire up to 2.5 mm<sup>2</sup>(AWG13). We recommend using twisted pair cables between Master and follower for communication signals.

1. Connect a level sensor between terminals 1 (+10 VDC) and 2 (AnIn 1) as in Fig. 14 The default setting for the AnIn1 is 4-20 mA. If the level sensor has a 0-10 V interface, change the position of the jumper (S1) on control board (chapter 3.3 page 30).
2. Connect an external Full speed switch between terminal 11 (+24 VDC) and 8 (DigIn1, Flow Run) as in Fig. 14. Set the switch in the open position (digital input set to low state). (Do not activate the signal at this point.)
3. Connect an external Auto run switch between terminal 11 (+24 VDC) and 9 (DigIn2, Flow Auto) as in Fig. 14. Set the switch in the open position (digital input set to low state). (Do not activate the signal at this point.)
4. Connect a communication cable between Master terminal 10 (DigIn3) and Follower terminal 21 (DigOut2) as in Fig. 14. (Only if Master/Follower).
5. Connect a communication cable between Master terminal 21 (DigOut2) and Follower terminal 10 (DigIn3) as in Fig. 14. (Only if Master/Follower).
6. Connect an overflow level switch (optional) between terminal 11 (+24 VDC) and 18 (DigIn6, Lvl Overflow) as in Fig. 14 Connect the signal to the Follower drive instead in a Master-Follower configuration for redundancy.

### Single pump or two pump configuration

Emotron FlowDrive can work in three different modes:

- Stand alone - One single pump
- Master - Main unit in a two pump configuration
- Follower - Second pump in a two pump configuration

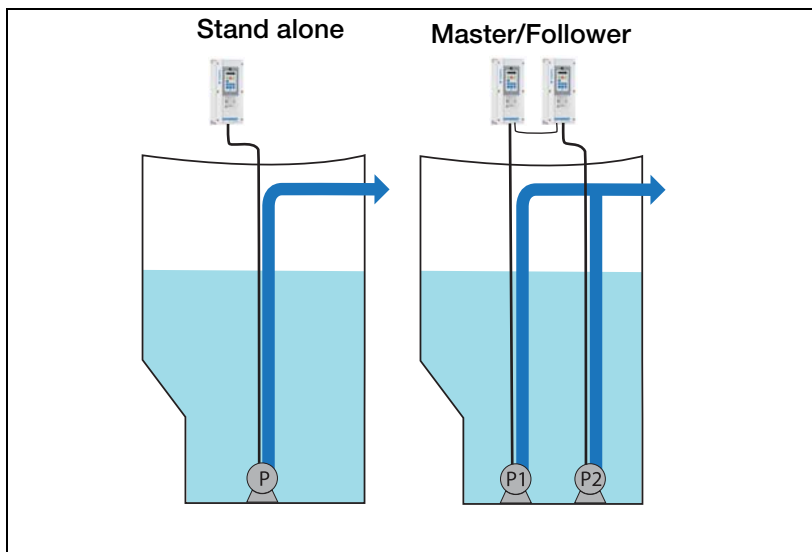

*Fig. 13 Stand alone and Master/Follower configuration.*

See next page for wiring examples of the different configurations.

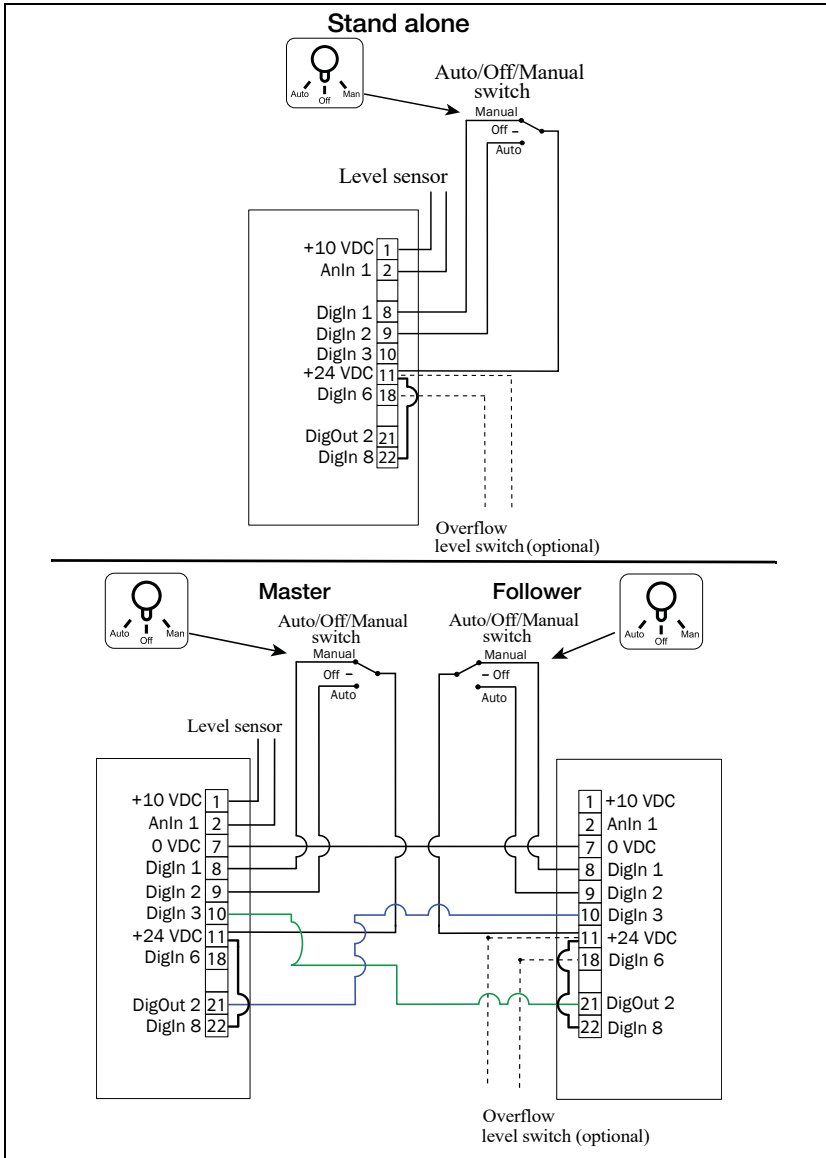

Fig. 14 General control I/O minimum wiring examples.

Table 12 Terminals and description of functions.

Stand alone / Master			Follower		
Term.	Name	Description	Term.	Name	Function
<b>Analogue inputs</b>					
2	AnIn 1	Level sensor			
<b>Outputs</b>					
1	+10V	+10V DC supply voltage			
7	0 VDC	Common	7	0 VDC	Common
11	+24V	+24V DC supply voltage	11	+24V	+24V DC supply voltage
<b>Digital inputs</b>					
8	DigIn 1	Flow ManRun (Forced run)	8	DigIn 1	Flow ManRun (Forced run)
9	DigIn 2	Flow AutoRun (Auto run)	9	DigIn 2	Flow AutoRun (Auto run)
10	DigIn 3	FlowLinkIn (Follower feedback)	10	DigIn 3	FlowLinkIn (Follower control)
18	DigIn 6	Overflow level switch (optional)	18	DigIn 6	Overflow level switch (optional)
22	DigIn 8	Reset	22	DigIn 8	Reset
<b>Digital outputs</b>					
21	DigOut 2	FlowLinkOut (Follower control)	21	DigOut 2	FlowLinkOut (Follower feedback)

### 3.4.1 Full wiring examples

#### FlowDrive Stand alone

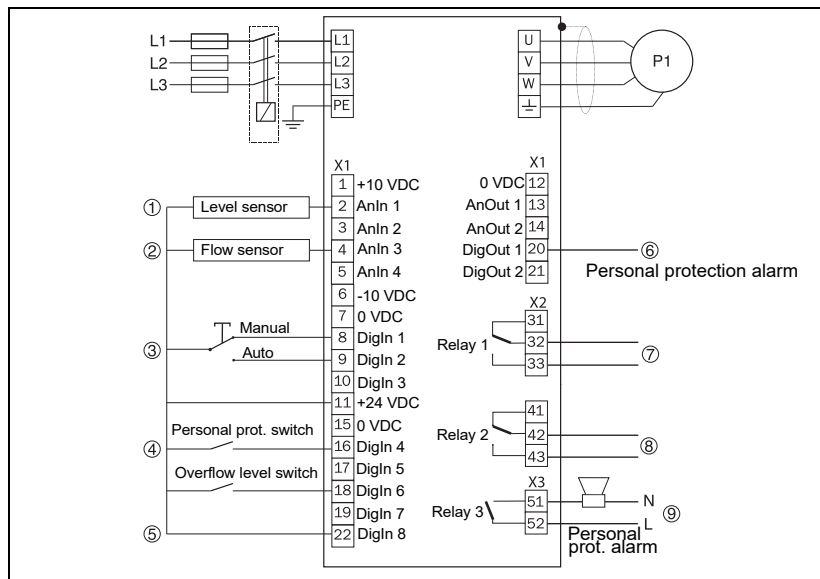

Fig. 15 FlowDrive standalone full wiring examples.

Pos. Nr	Function	Term.	De-scription	Menu	Default setting	Customer setting
1	Level sensor	2	AnIn 1	511	Level sensor	
2	Flow sensor	4	AnIn 3	517	Off	Flow sensor
3	Auto/Off/Manual switch	8	DigIn 1	521	Flow ManRun	
		9	DigIn 2	522	Flow AutoRun	
4	Personal protection switch	16	DigIn 4	524	Off	PP Timer
5	Autoreset enabling	22	DigIn 8	528	Reset	
6	Personal protection alarm	20	DigOut 1	541	Ready	PP alarm
7	Trip relay output	32 - 33	Relay 1	551	Trip	
8	Operation relay output	42 - 43	Relay 2	552	Run	
9	Personal protection pre-alarm	51 - 52	Relay 3	553	Off	PP PreAlarm

## FlowDrive Master / Follower

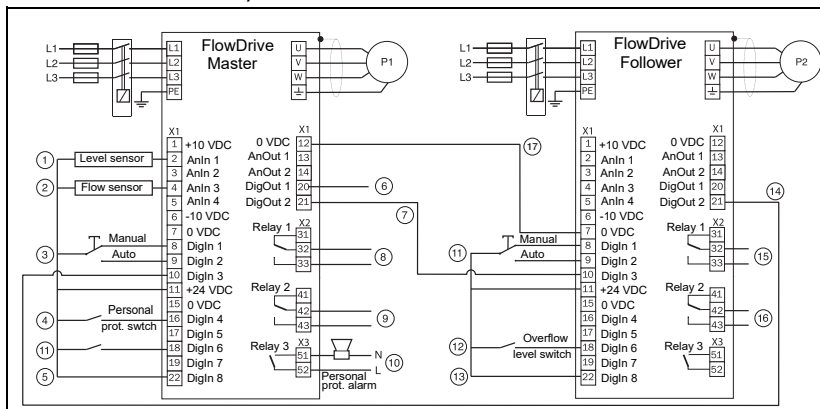

Fig. 16 FlowDrive Master/follower full wiring example.

Pos. Nr	Function	Unit	Term.	De-scription	Menu	Default setting	Customer setting
1	Level sensor	Master	2	AnIn 1	511	Level sensor	
2	Flow sensor	Master	4	AnIn 3	517	Off	Flow sensor
3	Auto/Off/Manual switch - Master	Master	8	DigIn 1	521	Flow Man-Run	
		Master	9	DigIn 2	522	Flow Auto-Run	
4	Personal protection switch	Master	16	DigIn 4	524	Off	PP Timer
5	Autoreset enabling	Master	22	DigIn 8	528	Reset	
6	Personal protection alarm	Master	20	DigOut 1	541	Ready	PP Alarm
7	Master/Follower communication	Master	21	DigOut 2	542	FlowLink-Out	
		Follower	10	DigIn 3	523	FlowLinkIn	
8	Trip relay output	Master	32 - 33	Relay 1	551	Trip	
9	Operation relay output	Master	42 - 43	Relay 2	552	Run	
10	Personal protection pre-alarm	Master	51 - 52	Relay 3	553	Off	PP PreAlarm

## Installation & Getting started

---

Pos. Nr	Function	Unit	Term.	Description	Menu	Default setting	Customer setting
11	Auto/Off/Manual switch - Follower	Follower	8	DigIn 1	521	FlowMan-Run	
		Follower	9	DigIn 2	522	FlowAuto-Run	
12	Overflow level switch	Master & Follower	18	DigIn 6	526	Lvl Overflow	
13	Autoreset enabling	Follower	22	DigIn 8	528	Reset	
14	Master/Follower communication	Follower	21	DigOut 2	542	FlowLink-Out	
		Master	10	DigIn 3	523	FlowLinkIn	
15	Trip relay output	Follower	32 - 33	Relay 1	551	Trip	
16	Operation relayoutput	Follower	42 - 43	Relay 2	552	Run	
17	Common, signal ground	Master	12	0 VDC			
		Follower	7				

## 4. Mount the cover

### Frame size A3 and B3

On the completion of wiring, insert the quick-release latches at the upper part of the cover into the grooves in the centre housing as indicated by number "1" in Fig. 17, then push in the lower part of the cover as indicated by number "2". A clicking noise indicates that the cover is correctly attached.

### Frame size C3

On the completion of wiring, insert the quick-release latches at lower part of the cover, fitting the screw and the quick-release latches into the grooves in the centre housing as indicated by number "1" in Fig. 17, then push in the upper part of the cover as indicated by number "2". A clicking noise indicates that the cover is correctly attached. Tighten the screw with your fingers (at position 1).

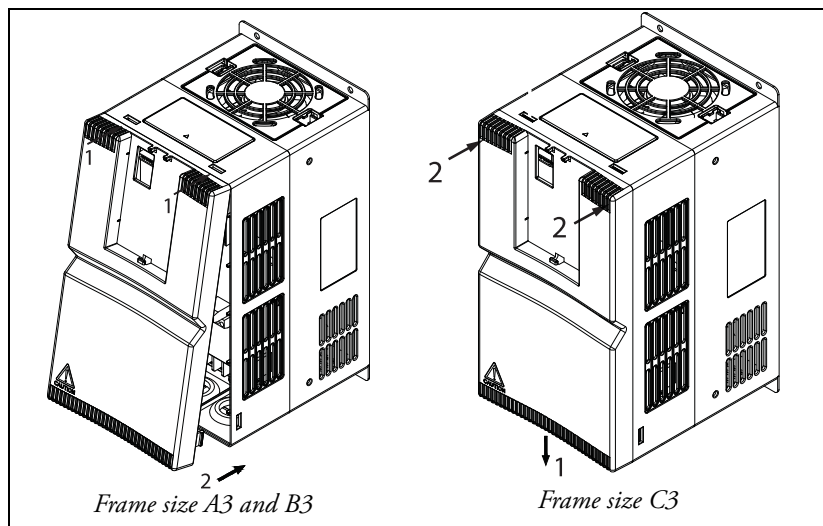
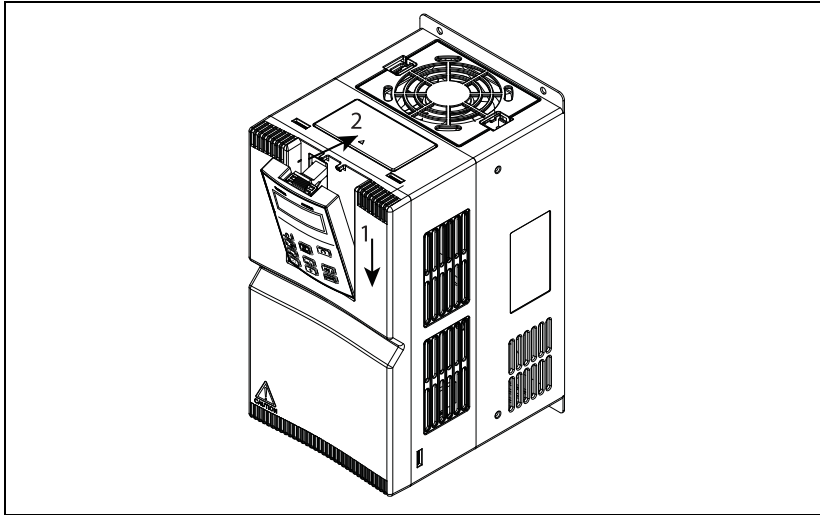

Fig. 17 Mount the cover.

### 4.1 Mount the keypad

Slightly tilt the keypad in the direction as indicated by number "1" in Fig. 6 and align it to quick-release latches at lower part of keypad bracket, then press it in as indicated by "2". A clicking noise indicates that the cover is correctly attached.



*Fig. 18 Mount the keypad*

# 5. Getting started

This chapter is a step by step guide that will show you the quickest way to get the pumps running.

We assume that:

- the AC drive is mounted on a wall or in a cabinet as in the chapter 2.4 page 17.
- mains and motor cable are connected according to chapter 3.1 page 22.
- control cables are connected according to chapter 3.2 page 26.

FlowDrive can operate as a Standalone unit (1 AC drive) or in a Master-Follower configuration (2 AC drives).

## Sections

Chapter 5.1- Describes the control panel and the display.

Chapter 5.2 - Describes how to use the function keys on the control panel.

Chapter 5.3 - Covers basic configuration like language and motor parameters for all drives.

Chapter 5.4 - Describes configuration of Standalone/Master drive.

Chapter 5.4.3 to Chapter 5.4.6 - Describes configuration of level control parameters related to the pump sump.

Chapter 5.6 - Describes how to start up the system and make sure everything is correctly configured.

Chapter 5.7 - Run the Auto Tune program.

Chapter 5.8 - Configuration of additional features.

## 5.1 Control panel

The control panel on Emotron FlowDrive - IP2Y version AC drives has a two lines display and buttons according to Fig. 19.

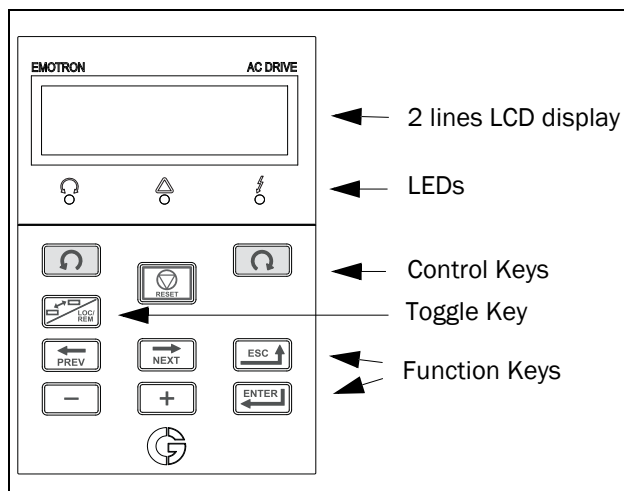

Fig. 19 Control panel display, LEDs and Keys.

### 5.1.1 The display

The display is back lit and consists of 2 rows, each with space for 16 characters. The display is divided into six areas.

The different areas in the display are described below:

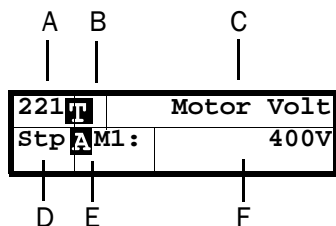

Fig. 20 The display

Area A: Shows the actual menu number (3 or 4 digits).

## Installation & Getting started

---

Area B Shows if the menu is in the toggle loop or the AC drive is set for Local operation.

Area C: Shows the heading of the active menu.

Area D \*: Shows the status of the AC drive (3 digits).

The following status indications are possible:

Digits	Description	Bit*
Stp	Motor is stopped	0
Run	Motor runs	1
Acc	Acceleration	2
Dec	Deceleration	3
Trp	Tripped	4
SST	Operating Safe Stop, is flashing when activated	5
VL	Operating at voltage limit	6
SL	Operating at speed limit	7
CL	Operating at current limit	8
TL	Operating at torque limit	9
OT	Operating at temperature limit	10
I <sup>2</sup> t	Active I <sup>2</sup> t protection	11
LV	Operating at low voltage	12
Sby	Operating from Standby power supply	13
LCL	Operating with low cooling liquid level	14
Slp	Sleep mode	15
SPS	Spin start active	16

\*) The status shown in Area D on the control panel can be read via a fieldbus or serial communication, e.g. using Modbus address nr 30053.

It is also possible to read all status indications, not just the highest prioritized one, via a fieldbus or serial communication, e.g. using Modbus address nr 30180 and 30182. This information is also shown in EmoSoftCom PC-tool (optional) see menu “Area D stat [72B]”.

Area E: Shows active parameter set and if it is a motor parameter.

Area F: Shows the setting or selection in the active menu. This area is empty at the 1st level and 2nd level menu. This area also shows warnings and alarm messages. In some situations this area could indicate “+++” or “- - -” please see further information in Chapter 5.1.2 page 43



```
300 Process
Stp A
```

*Fig. 21 Example 1st level menu*

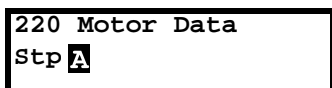

```
220 Motor Data
Stp A
```

*Fig. 22 Example 2nd level menu*

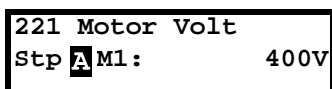

```
221 Motor Volt
Stp A M1:      400V
```

*Fig. 23 Example 3d level menu*

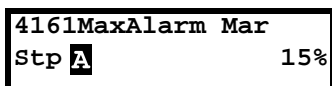

```
4161MaxAlarm Mar
Stp A      15%
```

*Fig. 24 Example 4th level menu*

### 5.1.2 Indications on the display

The display can indicate “+++” or “- - -” if a parameter is out of range. In the AC drive there are parameters which are dependent on other parameters. For example, if the speed reference is 500 and the maximum speed value is set to a value below 500, this will be indicated with “+++” on the

display. If the minimum speed value is set over 500, “- - -” is displayed.

### 5.1.3 LED indicators

The symbols on the control panel have the following functions:

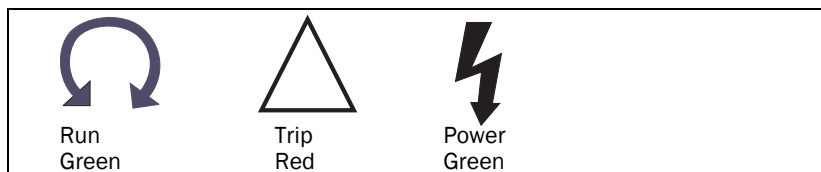

*Fig. 25 LED indications*

*Table 13 LED indication*

Symbol	Function		
	ON	FLASHING	OFF
<b>POWER (green)</b>	Power on	-----	Power off
<b>TRIP (red)</b>	AC drive tripped	Warning/Limit	No warning or trip
<b>RUN (green)</b>	Motor shaft rotates	Motor speed increase/decrease	Motor stopped

### 5.2 Function keys

The function keys operate the menus and are also used for programming and read-outs of all the menu settings.



step to lower menu level or confirm changed setting



step to higher menu level or ignore changed setting



step to next menu on the same level



step to previous menu on the same level



increase value or change selection



decrease value or change selection



- Toggle between menus in the toggle loop
  - Switching between local and remote control
  - Change the sign of a value
-

### 5.2.1 Using the function keys

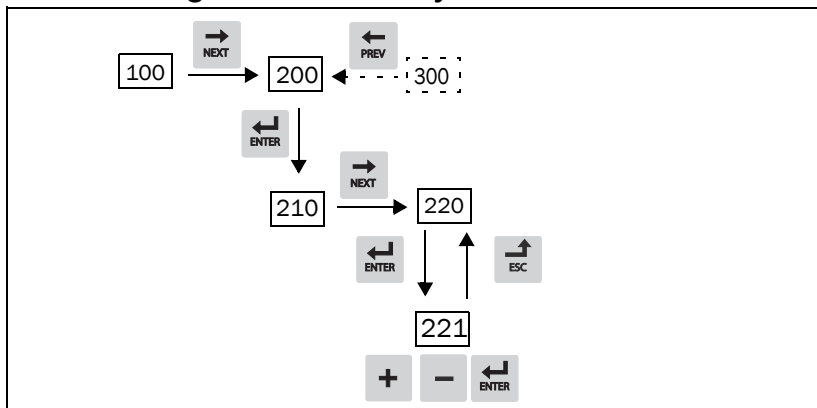

Fig. 26 Example of menu navigation when entering motor voltage

#### Example:

Setting Motor data.

Menu [100], “Preferred View” is displayed when started.

1. Press **NEXT** to display menu [200], “Main Setup”.
2. Press **ENTER** and then **NEXT** two times to display menu [220], “Motor Data”.
3. Press **ENTER** to display menu [221] and set motor voltage.
4. Change the value using the **+** and **-** keys. Confirm with **ENTER**.

### 5.2.2 Toggle loop

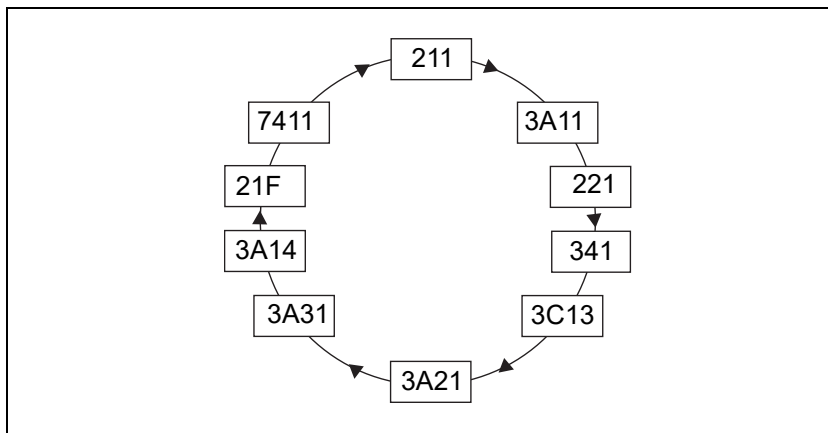

*Fig. 27 Default toggle loop*

To ease commissioning there is a pre-programmed default toggle loop that can be used to jump between the parameters described in this guide. Often other settings adjacent to these entry points should also be configured.

- [211] Language - Select language and supply voltage
- [3A11] Drive Conf.- Configuration of AC drive (Standalone/Master/Follower)
- [221] Motor Volts - Motor configuration
- [341] Min speed - Speed configuration
- [3C13] Sensor min – Level sensor configuration
- [3A21] Overflow – Configurations of levels (where to start, stop pumping etc.)
- [3A31] Level 1 – Reservoir configuration
- [3A14] RunTimeOFsw – Run time after overflow switch
- [21F] CopyToFLW – Copy to follower
- [7411] Sump level – Inspect values and test operation

### 5.3 Basic configuration (all AC drives)

The FlowDrive can work in two drive modes; WasteWater and Generic drive mode.

In WasteWater mode the AC drive is configured for reservoir level control and in Generic drive mode it behaves like a normal Emotron FDU drive. By default the AC drive is configured in WasteWater mode and the remaining quick start guide describes how to configure this mode.

In case you are interested in running the FlowDrive as a Generic drive, change parameter “[21D] Drive appl.” to “Generic” and consult the instruction manual for FDU in the download area (file archive) on [www.emotron.com](http://www.emotron.com). Please note that there is a slight difference in the menu layout and some parameters have changed fieldbus addresses.

#### 5.3.1 Switch on the mains

Once the mains is switched on, the internal fan in the AC drive will run for 5 seconds (In frame size A3 the fan runs continuously). The control panel is lighted up and the AC drive can be configured.

To change settings use the keys on the control panel or remote access program such as EmoSoftCom. For further information about the control panel, EmoSoftCom and menu structure, see the software instruction

#### 5.3.2 Language and supply voltage

Menu [100], “Preferred View” is displayed when started.

1. Navigate to menu [211] or press toggle button once and you will jump directly to menu “[211] Language” – Set preferred language.
2. Now navigate to “Mains supply voltage [21B]” and set supply voltage according to the actual drive supply voltage used.

### 5.3.3 Set FlowDrive configuration

In FlowDrive WasteWater mode the AC drive can operate as a Standalone unit (using one AC drive) or in a Master-Follower configuration (using two AC drives). Select the configuration that fits your setup:

#### Standalone configuration

1. Navigate to menu “[3A11] FLD Config” or press toggle button once more and you will jump directly to menu [3A11].
2. Verify that “FLD Config” is configured to “Standalone” (factory default). If not change it to “Standalone”.
3. Continue with “5.4 Standalone / Master configuration”.

#### Master-Follower configuration

1. On the follower unit navigate to menu “[3A11] FLD Config” or press toggle button once more and you will jump directly to menu [3A11].
2. Set “FLD Config” to “Follower”.  
This concludes the setup for the Follower unit! Continue with configuration of Master unit below and then copy common parameters as outlined later in this guide.  
NOTE: Setting the parameter to “Follower” will cause a warning (blinking red triangle on PPU). Warning is “P2 Comm Err”, can be seen in menu [722], and occurs because there is no configured Master unit to communicate with yet.
3. On the Master unit navigate to menu “[3A11] FLD Config” or press toggle button once more and you will jump directly to menu [3A11].
4. Set “FLD Config” to “Master”.
5. Make sure that there are no warnings/errors (triangle on PPU should not blink nor be lit) on either Master or Follower.
6. Continue with “5.4 Standalone / Master configuration”

### 5.4 Standalone / Master configuration

---

**NOTE: “5.3 Basic configuration (all AC drives)” should be done before entering here.**

---

#### 5.4.1 Set the Motor Data

Navigate to menu [221] or press toggle button once and you will jump directly to menu [221].

Enter correct motor data for the connected motor. Change settings using the keys on the control panel. For further information about the control panel and menu structure, see the software instruction.

1. Set motor voltage [221].
2. Set motor frequency [222].
3. Set motor power [223].
4. Set motor current [224].
5. Set motor speed [225].
6. Set power factor ( $\cos \varphi$ ) [227].

---

**Note: User with 60Hz motors must change the values in menus: “Flush speed [3B12]” & “Rev speed [3B34]” from 50 to 60 Hz.**

---

#### 5.4.2 Minimum frequency

Navigate to “[341] Min frequency” or press toggle button again to set the minimum allowed frequency.

[341] Min frequency

Minimum frequency is by default set to nominal motor frequency and must be changed by the user. Generally 70% of nominal motor frequency is a good value to start with. I.e. 35Hz in case nominal motor frequency is 50Hz. This is low enough to be able to find the best efficiency point and high enough to ensure that the pump generates a sufficient flow. Adjust upwards if the default value is considered to be too low for keeping up with normal inflow.

### 5.4.3 Level sensor configuration

The level sensor connected to the standalone or master unit needs to be configured based on its type and placement. Navigate to menu [3C13] or press the toggle button.

1. “[3C13] Sensor min”  
This is configuration of which level, in meters, the min analogue signal from the sensor should represent. Generally this is 0 for a pressure sensor placed in the bottom of the sump. Press  to continue.
2. “[3C14] Sensor max”  
This is configuration of which level, in meters, the max analogue signal from the sensor represents. This data is dependent on the sensor but often sensors with a range of 5 or 10 meters is used.





See also Fig. 28, page 53.

Regarding more advanced functions please refer to the Software instruction manual

### 5.4.4 Set sump levels

Set the desired levels for actions to be taken (starting and stopping of the pumps), see Fig. 28, page 53.

Navigate to menu [3A21] or press the toggle button again and set following.

1. “[3A21] Overflow “ Level where the overflow alarm is triggered. Press  to continue.
2. “[3A22] Start level” Level where the pump is started, Press  to continue.
3. “[3A23] Stop level” Level where the pump is stopped Press  to continue.
4. “[3A27] Full speed” Level where all available pumps are started, running at full speed. Press  to continue.

---

**Note: Overflow level has to be higher than Start level which has to be higher than Stop level. Full speed level should be between overflow and start level. In general, the overflow level shall be set somewhat below the Overflow switch (If installed) see Fig. 28.**

---

### 5.4.5 Set reservoir geometry

The reservoir geometry settings are crucial for the Auto Tune program and flow estimations. Enter values as precisely as possible, failing to do so will result in inaccurate measurements.

Navigate to menu “[3A31] Level 1” or press toggle button.

Start from the bottom level (level 1) and set a corresponding area for each change of shape in the reservoir. Remember to deduct the area of the pumps if this area is large enough to affect the flow estimations.

It is possible to use 5 levels and areas. Use as many as required, unused levels/ areas should be set to 0/Off.

Last level defined is extrapolated, hence in a uniformed sump only one level/ area is required.

Level 1 [3A31]	Area 1 [3A32]
Level 2 [3A33]	Area 2 [3A34]
Level 3 [3A35]	Area 3 [3A36]
Level 4 [3A37]	Area 4 [3A38]
Level 5 [3A39]	Area 5 [3A3A]

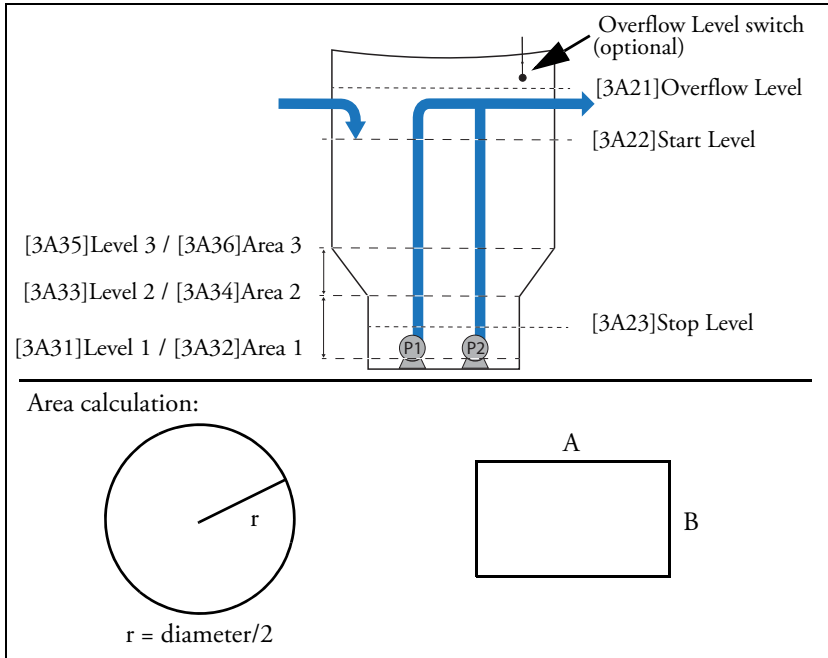

Fig. 28 Sump areas and levels, examples.

## Example with round reservoir:

Level= X m,

$$\text{Area} = \pi r^2$$

Level 1 = 0 m

Area 1 = Radius is 0.60 m, area 1 is calculated:

$$\pi 0.60^2 = 1.13\text{m}^2$$

Level 2 = 0.50 m,

Area 2 = Radius is 0.60 m, area 2 is calculated:

$$\pi 0.60^2 = 1.13\text{m}^2$$

Level 3 = 0.60 m

Area 3 = Radius 0.90 m, area 3 is calculated:

$$\pi 0.90^2 = 2.54\text{m}^2$$

Example with rectangular reservoir:

Level= X m,

Area = A x B m<sup>2</sup>

Level 1: 0 m

Area 1 : A= 1.20 m, B= 0.50 m, area 1 is calculated:

$$1.20 \times 0.50 = 0.60 \text{ m}^2$$

Level 2 = 0.50 m,

Area 2 : A= 1.20 m, B= 0.50 m, area 2 is calculated:

$$1.20 \times 0.50 = 0.60 \text{ m}^2$$

Level 3 = 0.60 m

Area 3 : A= 1.80 m, B= 0.50m, area 3 is calculated:

$$1.80 \times 0.50 = 0.90 \text{ m}^2$$

### Examples of reservoir shapes and levels

Following are examples of different reservoir shapes and levels required.

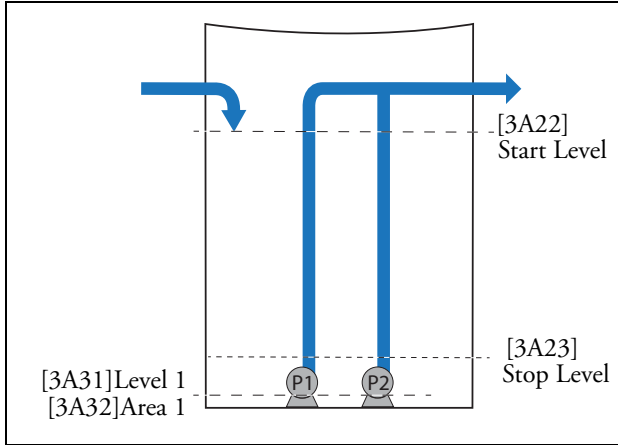

Fig. 29 With a uniform shape, only one level (area) is required as the area is the same.

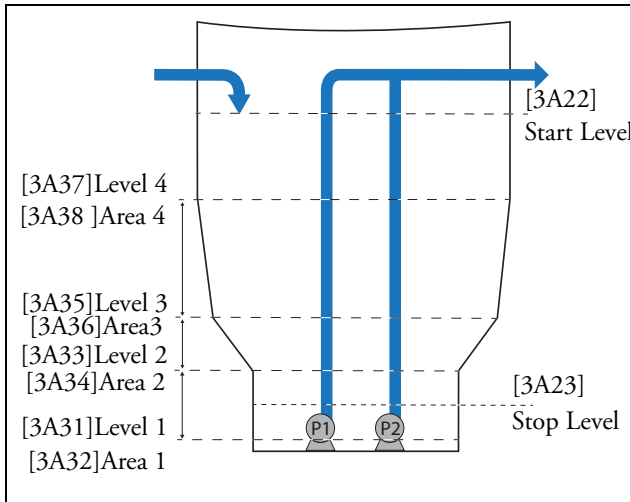

Fig. 30 With this shape, 4 levels and areas are required.

### 5.4.6 Overflow level switch runtime

If there is an overflow level switch connected to digital in on either Master or Follower unit (not to mix up with “[3A21] Overflow” level) consider changing the minimum run time in menu “[3A14] RnTimeOFsw” when switch is activated. Default is 0 minutes implying only run when activated.

[3A14] RunTimeOFsw

Number of minutes to run after overflow switch is activated.

## 5.5 Copy to follower

In case of a Master and Follower system it is now time to copy parameters to the follower. On a “Standalone” system skip this part.

Navigate to menu “[21F] CopyToFlw” or press the toggle button.

1. Make sure the drives are in stopped mode.
2. Set to “Copy” and press Enter.
3. Verify that “Done” emerge after a while.

## 5.6 Test run

Now the configuration is finished; time to test that everything works as expected.

### Sump level

Sump level is shown in menu “[7411] Sump level” (and by default as first row in [100] menu).

Navigate to menu “[7411] Sump level” or press toggle button and make sure the current sump water level displayed corresponds to actual level in the sump.

### Auto/Off/Manual switches

Make sure the external Auto/Off/Manual switches are set in correct position and connected correctly as described in chapter 3.4 page 31.

1. Set both switches in “Off” position.
2. Go to menu “[746] Pump mode” on the Master AC drive. In this menu the mode for the pumps are shown.

3. Make sure “Off” is shown for both pumps in this menu.  
In case not “Off” is shown for both pumps, make sure the switches are in correct position and connected correctly. Also inspect the configuration in menu “[52X] DigIn X” where X is the digital input number.
4. Turn the Auto/Off/Manual switch to Manual for one of the pumps. The corresponding pump should start and “[746] Pump mode” should change to “Manual” for the corresponding pump (the other pump should stay in “Off” state). Test both pumps. Switch both back to “Off”.
5. Change both switches to Auto.
6. “[746] Pump mode” should change to “Auto” mode.

### Verify “Auto mode” operation

In “Auto” pump mode the pump should start when “[7411] Sump level” has reached “[7412] ActStartLvl” (that should be same as configured “[3A22] Start level” unless “[3B2] Start lvl Δ” is configured). Monitor how the pump decreases the level and eventually comes to a stop when “[7411] Sump level” goes below “[3A23] Stop level”.

## 5.7 Engage “Auto Tune” program to optimize energy consumption

When concluded that the FlowDrive appears to be running correctly in Auto mode as described earlier, the “Auto Tune” program can be started. It is designed to measure reference outflows and find the best efficiency point. In addition the Auto Tune program can configure the load monitor enabling detection of obstructed pumps.

### Load monitor

- Auto Tune program starts with measuring the normal load at different frequencies.  
It is possible to deselect the Load monitoring in menu “[3A42] LoadMonTune” if you for some reason need to repeat the BEP calculation.

### Start Auto Tune

The Auto Tune program will do a lot of measurements and will take several hours, up to days, to complete. If pump cleaning is allowed the program will start with cleaning the pumps, making sure pumps are cleaned before taking measurements. Then continue with load monitor tuning if enabled and finally run the flow and efficiency measurements. During flow and efficiency measurements the FlowDrive will use a narrow start/stop interval located slightly below the normal start level.

The AutoTune program will do "[3A43] BEP samples" of measurements at each frequency. However, if a sample measurement is considered faulty (e.g. when inflow is changed a lot or is too high) that measurement will be discharged and redone. The progress of the AutoTune program can be seen in menu "[752] BEP progress" as a percentage. When successfully finalized "[751] BEP State" will show "Finished". Under certain conditions (too many faulty measurements in a row) the AutoTune program will be aborted. In that case menu "[751] BEP State" will show "Aborted" and abort reason can then be seen in "[7531]AbortReason".

After completion, or if aborted, the AC drive will automatically jump into normal running mode.

- Navigate to menu [3A41].  
"[3A41] Start AutoT" – Set to "Start" to initiate the Auto Tune program

The progress can be seen in menu "[752] BEP progress" as a percentage. When finished the result can be seen in the following parameters:

"[349] BEP Speed" – The frequency where it is most efficient to pump at.

"[94X] Flow log 1P" – Log of outflow and energy data for one pump at different frequencies.

"[95X] Flow log 2P" – Log of flows and energy data for two pumps at different frequencies.

"[41CX] Load Curve" – If load monitor was configured load data at different frequencies can be found here.

### 5.8 Configuration of additional features (optional)

Here is an overview of some of the additional features built into the FlowDrive. More detailed information can be found in the Software instruction

#### 5.8.1 Flush start

Function to always ramp up to full speed to get sludge and sediment moving. Flushing time and frequency can be configured in [3B1X] menus. By default this feature is turned on.

#### 5.8.2 Random start level

To avoid building up residues at start level on the sump wall, it is possible to randomize where the pumps are started. By default randomized start level is turned off.

Activate this function by setting start level in “[3B2]Start lvl Δ”, by default this is set to off.

“[3B2] Start lvl Δ “ – Set the desired variation in meters.

#### Example

Start level is set to: 1.5 meters

Start lvl Δ is set to: 0.4m

Actual start level will then be randomized between 1.1m-1.5m.

#### 5.8.3 Pump cleaning

Pump cleaning runs the pump in a specific pattern in both forward and reverse direction to clean the pump from rugs and dirt buildup. By default this feature is turned off since not all pumps can operate in reverse direction.

---

**NOTE: Pump cleaning will reverse the pumps. Check with the pump manufacturer that the connected pump can operate in the reverse direction.**

---

“[3B31] Act.PumpCln”

Set to ‘Yes’ to allow pump cleaning.

“[3B36] CleanTorque”

Set maximum allowed clean torque. Often there will be a need for some additional torque when cleaning compared to normal run conditions.

### 5.8.4 Sump cleaning

This function helps getting rid of accumulated residues in the pump sump. Pump sump cleaning empties the pump sump by running the selected pump(s) below the normal stop level until slurping air. Detection of when to stop is based on the decrease in load when starting to slurping air.

---

**NOTE 1: Running pumps below their normal stop level might cause the pump to overheat.**

**NOTE 2: Problems might emerge from sucking air into the pump/pipes in some installations (generally dry setups).**

**NOTE 3: The load drop percentage ([3B43] Off Torque  $\Delta$ ), i.e. when to stop, must be configured and tested for optimal functionality.**

---

### 5.8.5 Pipe cleaning

Pipe cleaning function produce maximum flow for as long time as possible to clean the pipes from loose residues. Pipe cleaning can be activated at any time and will be performed as soon as the start level is reached.

## 6. Options

The standard options available are described here briefly. Some of the options have their own instruction or installation manual. For more information please contact your supplier. See also in “Technical catalogue Emotron FlowDrive” for more info.

### 6.1 EmoSoftCom

EmoSoftCom is an optional software that runs on a personal computer. It can also be used to load parameter settings from the AC drive to the PC for backup and printing. Recording can be made in oscilloscope mode. Please contact CG Drives & Automation sales for further information.

### 6.2 I/O Board

Part number	Description
01-6070-01	I/O option board 2.0 (micro) - Coated

Each I/O option board 2.0 provides three extra relay outputs and three extra isolated digital inputs (24V). The I/O Board works in combination with the Pump/Fan Control, but can also be used as a separate option. Maximum 2 I/O boards possible. This option is described in a separate manual.

### 6.3 RS232/485

Part number	Description
01-6070-07	RS232/485-2Y (micro) option board- Coated

The RS232/485 option board for serial communication is described in a separate manual. The interface has galvanic isolation.

### 6.4 PTC/RTC

Part number	Description
01-6070-08	PTC/RTC-2Y (micro) option board - Coated

The PTC /RTC option board is a combined option board for:

- connecting motor thermistors as described in a separate manual.
- RTC-Realtime clock function, makes it possible to start functions e.g. sump cleaning or pipe cleaning at desired date, time or weekday.

### 6.5 Serial communication and fieldbus

Part number	Description*
01-6070-04	RS232/485
01-6070-05	Profibus DP
01-6070-06	DeviceNet
01-6070-09	Modbus/TCP, Industrial Ethernet
01-6070-14	Modbus/TCP, two port m M12 Industrial Ethernet
01-6070-10	EtherCAT, Industrial Ethernet
01-6070-11	Profinet IO, one port Industrial Ethernet
01-6070-12	Profinet IO, two port Industrial Ethernet
01-6070-13	EtherNet/IP, two port industrial EtherNet

\*) Note that all option boards in FlowDrive shall be ordered coated.

For communication with the AC drive there are several option boards for communication. There are different options for Fieldbus communication and one serial communication option with RS232 or RS485 interface which has galvanic isolation.

### 6.6 Standby supply board option

Part number	Description
01-6070-00	Standby power supply kit for after mounting. - Coated

The standby supply board option provides the possibility of keeping the communication system up and running without having the 3-phase mains connected. One advantage is that the system can be set up without mains power. The option will also give backup for communication failure if main power is lost.

The standby supply board option shall be supplied with external  $\pm 10\%$  24 V<sub>DC</sub> protected by a 2 A slow acting fuse, from a double isolated transformer. The terminals - and + are voltage polarity dependent.

### 6.7 Safe Stop option

Part number	Description
01-6070-02	Safe Stop-2Y (micro) option board - Coated

To realize a Safe Stop configuration in accordance with Safe Torque Off (STO) EN-IEC 62061:2005 SIL 2 & EN-ISO 13849-1:2006, the following three parts need to be attended to:

1. Inhibit trigger signals with safety relay K1 (via Safe Stop option board).
2. Enable input and control of AC drive (via normal I/O control signals of AC drive).
3. Power conductor stage (checking status and feedback of driver circuits and IGBT's).

To enable the AC drive to operate and run the motor, the following signals should be active:

- "Inhibit" input, terminals 1 (DC+) and 2 (DC-) on the Safe Stop option board should be made active by connecting 24 V<sub>DC</sub> to secure the supply voltage for the driver circuits of the power conductors via safety relay K1. See also Fig. 32.

- High signal on the digital input, e.g. terminal 10 in Fig. 32, which is set to "Enable". For setting the digital input please refer to the Software instruction.

These two signals need to be combined and used to enable the output of the AC drive and make it possible to activate a Safe Stop condition.

---

**NOTE: The "Safe Stop" condition according to EN-IEC 62061:2005 SIL 2 & EN-ISO 13849-1:2006, can only be realized by de-activating both the "Inhibit" and "Enable" inputs.**

---

When the "Safe Stop" condition is achieved by using these two different methods, which are independently controlled, this safety circuit ensures that the motor will not start running because:

- The 24VDC signal is disconnected from the "Inhibit" input, terminals 1 and 2, the safety relay K1 is switched off.

The supply voltage to the driver circuits of the power conductors is switched off. This will inhibit the trigger pulses to the power conductors.

- The trigger pulses from the control board are shut down.

The Enable signal is monitored by the controller circuit which will forward the information to the PWM part on the Control board.

To make sure that the safety relay K1 has been switched off, this should be guarded externally to ensure that this relay did not refuse to act. The Safe Stop option board offers a feedback signal for this via a second forced switched safety relay K2 which is switched on when a detection circuit has confirmed that the supply voltage to the driver circuits is shut down. See Table 14 for the contacts connections.

To monitor the "Enable" function, the selection "RUN" on a digital output can be used. For setting a digital output, e.g. terminal 20 in the example Fig. 32, please refer to Menu [540] in the Software instruction.

When the "Inhibit" input is de-activated, the AC drive display will show a flashing "SST" indication in section D (bottom left corner) and the red Trip LED on the Control panel will be flashing.

To resume normal operation, the following steps have to be taken:

- Release "Inhibit" input; 24V<sub>DC</sub> (High) to terminal 1 and 2.
- Give a STOP signal to the AC drive, according to the set Run/Stop Control

in menu [215].

- Give a new Run command, according to the set Run/Stop Control in menu [215].

---

**NOTE:** The method of generating a STOP command is dependent on the selections made in Start Signal Level/Edge [21A] and the use of a separate Stop input via digital input.

---



**WARNING!**

The safe stop function can never be used for electrical maintenance. For electrical maintenance the AC drive should always be disconnected from the supply voltage.

---

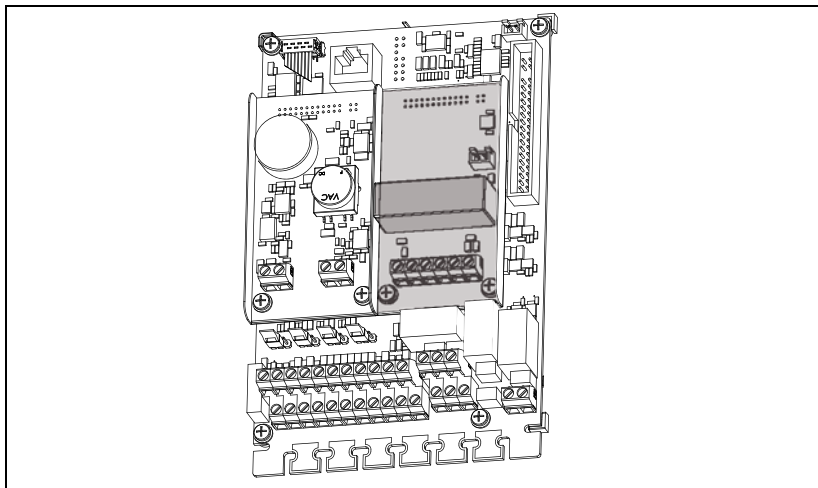

*Fig. 31 Connection of safe stop option.*

Table 14 Specification of Safe Stop option board

X1 pin	Name	Function	Specification
1	Inhibit +	Inhibit driver circuits of power conductors	DC 24 V (20–30 V)
2	Inhibit -		
3	NO contact relay K2	Feedback; confirmation of activated inhibit	48 V <sub>DC</sub> / 30 V <sub>AC</sub> /2 A
4	P contact relay K2		
5	GND	Supply ground	
6	+24 V <sub>DC</sub>	Supply Voltage for operating Inhibit input only.	+24 V <sub>DC</sub> , 50 mA

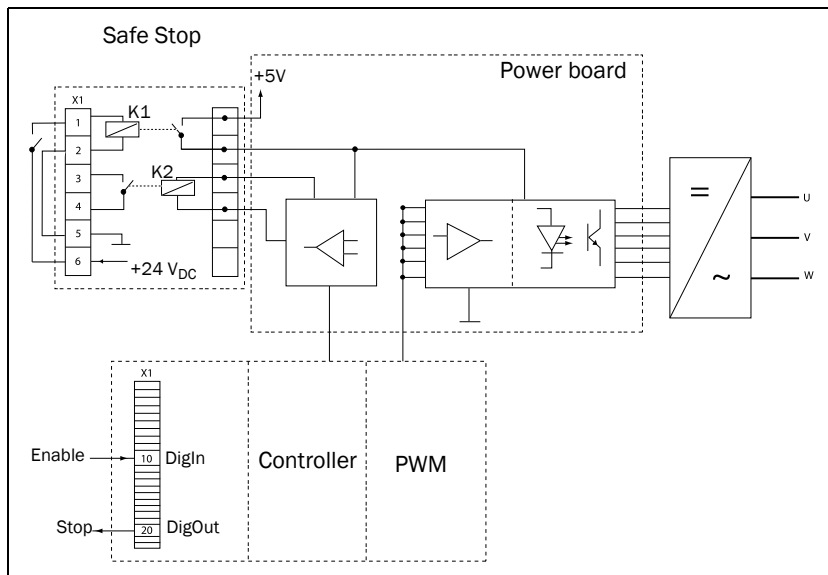

Fig. 32 Safe Stop connection

### 6.8 EMC filter class C2

EMC filter according to EN61800-3:2004 class C2 - 1st environment restricted distribution.

For more information see in “Technical catalogue AC drives”.

**Note:** EMC filter according to class C3 - 2nd environment included as standard in all drive units.

### 6.9 Other options

Following options are also available, for more information regarding these options, see in “Technical catalogue AC drives”.

Overshoot clamp

Sine wave filter

Common mode filter



Brake resistors

## 7. Menu List

On our home page in the download area, you could find a "Communication information" list and a list to note Parameter set information.

Some menus are marked with grey, see below, these menus are so called "Advanced menus":

3A24	BEP start	No	
------	-----------	----	--

To access the advanced menus, press  and  buttons simultaneously for 3 seconds. It is also possible to go to menu "[21E] MenuMode" and select FLD Advanced.

		Factory setting	Customer
100	Preferred View		
	110	1st Line	Sump level
	120	2nd Line	Frequency
200	Main Setup		
	210	Operation	
	211	Language	English
	212	Select Motor	M1
	213	Drive Mode	V/Hz
	214	Ref Control	Flow ctrl
	215	Run/Stp Ctrl	Flow ctrl
	216	Reset Ctrl	Rem+Keyb+Com
	218	Lock Code?	0
	219	Rotation	R+L
	21A	Level/Edge	Level
	21B	Supply Volts	Not Defined
	21C	Supply Type	AC supply
	21D	Drive Appl.	Waste water
	21E	MenuMode	Basic
	21F	CopyToFlw	Off
	21G	Autotoggle	
		21G1	Start delay 0s
		21G2	Toggle Time 5s
220	Motor Data		
	221	Motor Volts	$U_{NOM}$ V
	222	Motor Freq	50Hz
	223	Motor Power	$(P_{NOM})$ kW

## Installation & Getting started

		Factory setting	Customer
224	Motor Curr	(I <sub>MOT</sub> ) A	
225	Motor Speed	(n <sub>MOT</sub> ) rpm	
226	Motor Poles	4	
227	Motor Cosφ	Cosφ <sub>NOM</sub>	
228	Motor Vent	Self	
229	Motor ID-Run	Off	
22A	Motor Sound	F	
22E	Motor PWM		
	22E1	PWM Fswitch	3.00 kHz
	22E2	PWM Mode	Standard
	22E3	PWM Random	Off
22H	Phase order	Normal	
230	Mot Protect		
231	Mot I <sup>2</sup> t Type	Trip	
232	Mot I <sup>2</sup> t Curr	100%	
233	Mot I <sup>2</sup> t Time	60s	
234	Thermal Prot	Off	
235	Motor Class	F 140°C	
236	PT100 Inputs	PT100 1+2+3	
237	Motor PTC	Off	
240	Set Handling		
241	Select Set	A	
242	Copy Set	A>B	
243	Default>Set	A	
244	Copy to CP	No Copy	
245	Load from CP	No Copy	
250	Autoreset		
251	No of Trips	10	
252	Overtemp	Off	
253	Overvolt D	Off	
254	Overvolt G	Off	
255	Overvolt	6s	
256	Motor Lost	Off	
257	Locked Rotor	Off	
258	Power Fault	Off	
259	Undervoltage	6s	
25A	Motor I <sup>2</sup> t	60s	
25B	Motor I <sup>2</sup> t TT	Trip	

## Installation & Getting started

		Factory setting	Customer
25C	PT100	Off	
25D	PT100 TT	Trip	
25E	PTC	Off	
25F	PTC TT	Trip	
25G	Ext Trip	Off	
25H	Ext Trip TT	Trip	
25I	Com Error	Off	
25J	Com Error TT	Trip	
25K	Min Alarm	Off	
25L	Min Alarm TT	Trip	
25M	Max Alarm	Off	
25N	Max Alarm TT	Trip	
25O	Over curr F	Off	
25Q	Over speed	Off	
25R	Ext Mot Temp	Off	
25S	Ext Mot TT	Trip	
25T	LC Level	Off	
25U	LC Level TT	Trip	
260	Serial Com		
261	Com Type	RS232/485	
262	RS232/485		
	2621	Baudrate	38400
	2622	Address	1
263	Fieldbus		
	2631	Address	62
	2632	PrData Mode	Basic
	2633	Read/Write	RW
	2634	AddPrValues	0
264	Comm Fault		
	2641	ComFlt Mode	Off
	2642	ComFlt Time	0.5 s
265	Ethernet		
	2651	IP Address	0.0.0.0
	2652	MAC Address	000000000000
	2653	Subnet Mask	0.0.0.0
	2654	Gateway	0.0.0.0
	2655	DHCP	Off

# Installation & Getting started

			Factory setting	Customer
266	FB Signal			
	2661	FB Signal 1	0	
	2662	FB Signal 2	0	
	2663	FB Signal 3	0	
	2664	FB Signal 4	0	
	2665	FB Signal 5	0	
	2666	FB Signal 6	0	
	2667	FB Signal 7	0	
	2668	FB Signal 8	0	
	2669	FB Signal 9	0	
	266A	FB Signal 10	0	
	266B	FB Signal 11	0	
	266C	FB Signal 12	0	
	266D	FB Signal 13	0	
	266E	FB Signal 14	0	
	266F	FB Signal 15	0	
	266G	FB Signal 16	0	
	269	FB Status		
300	Process			
	3A0	Level Ctrl		
	3A1	Mode config		
		3A11	Drive conf.	Stand alone
		3A12	Start Sel.	Run time
		3A13	Empty time	240min
		3A14	RnTimeOfsw	0min
	3A2	Level config		
		3A21	Overflow	0
		3A22	Start Level	0
		3A23	Stop Level	0
		3A24	BEP start	0
		3A25	BEP stop	0
		3A26	PreOverflow	0
		3A27	Full speed	0
	3A3	Sump Geometry		
		3A31	Level 1	0
		3A32	Area 1	Off
		3A33	Level 2	0
		3A34	Area 2	Off

## Installation & Getting started

		Factory setting	Customer
3A35	Level 3	0	
3A36	Area 3	Off	
3A37	Level 4	0	
3A38	Area 4	Off	
3A39	Level 5	0	
3A3A	Area 5	Off	
3A4	Autotune		
3A41	Start AutoT	Off	
3A42	LoadMonTune	Yes	
3A43	BEP samples	5	
3A44	BEP step	2Hz	
3A45	MeasType	Off	
3B0	Functions		
3B1	Flush start		
3B11	Flush time	10s	
3B12	Flush speed	50Hz	
3B2	Start lvl $\Delta$	Off	
3B3	PumpCleaning		
3B31	Act.PumpCln	No	
3B32	ForcePumpCl	Off	
3B33	PumpCperiod	Off	
3B34	Rev. speed	50Hz	
3B35	ReverseTime	10s	
3B36	CleanTorque	Off	
3B37	Attempts	3	
3B3A	PC interval	Off	
3B3B	PCstartDate	2015-01-01	
3B3C	PCstartTime	Off	
3B4	SumpCleaning		
3B41	Act.SumpCln	Off	
3B42	ForceSumpCl	No	
3B43	Off Torque $\Delta$	50%	
3B44	Timeout	10min	
3B45	SumpCPeriod	Off	
3B4A	RecurInterv	0days	
3B4B	SCstartDate	2015-01-01	
3B4C	SCstartTime	00:00:00	

## Installation & Getting started

		Factory setting	Customer
3B5	PipeCleaning		
	3B51	ForcePipeC	No
	3B52	PipeCperiod	Off
3B6	LoadMonitor		
	3B61	LoadMonTune	Not Done
3B7	Reduced level		
	3B71	Reduction	25%
	3B71	Time	Off
3C0	Sensors		
3C1	Level sensor		
	3C11	Level Unit	m
	3C12	User unit	0
	3C13	Sensor min	0
	3C14	Sensor max	10
	3C15	Ratio	Linear
	3C16	Source	Local
3C2	Flow sensor		
	3C21	Flow Unit	Off
	3C23	Flow Min	0
	3C24	Flow Max	1000
	3C25	Ratio	Linear
	3C26	Source	Local
330	Start/Stop		
	331	Acc Time	4s
	332	Dec Time	4s
	335	Acc>Min Spd	4s
	336	Dec<Min Spd	4s
	337	Acc Rmp	Linear
	338	Dec Rmp	Linear
	339	Start Mode	Fast
340	Speed		
	341	Min speed	50Hz
	343	Max speed	Sync speed
	349	BEP Speed	0Hz
350	Torques		
	351	Max Torque	120%
	352	IxR Comp	Off
	353	IxR CompUsr	0%

## Installation & Getting started

		Factory setting	Customer
354	Flux optim	Off	
355	Max Power	Off	
370	Spd Ctrl PI		
371	Spd PI Auto	Off	
372	Spd P Gain	5	
373	Spd I Time	0.14s	
400	Monitor/Prot		
410	Load Monitor		
411	Alarm Select	Off	
412	Alarm trip	Off	
413	Ramp Alarm	Off	
414	Start Delay	5s	
415	Load Type	Load Curve	
416	Max Alarm		
4161	MaxAlarmMar	30%	
4162	MaxAlarmDel	10s	
417	Max Pre alarm		
4171	MaxPreAlMar	20%	
4172	MaxPreAlDel	5s	
418	Min Pre Alarm		
4181	MinPreAlMar	20%	
4182	MinPreAlDel	5s	
419	Min Alarm		
4191	MinAlarmMar	30%	
4192	MinAlarmDel	10s	
41A	Autoset Alm	No	
41B	Normal Load	100%	
41C	Load Curve		
41C1	Load Curve 1	0 rpm 100%	
41C2	Load Curve 2	0 rpm 100%	
41C3	Load Curve 3	0 rpm 100%	
41C4	Load Curve 4	0 rpm 100%	
41C5	Load Curve 5	0 rpm 100%	
41C6	Load Curve 6	0 rpm 100%	
41C7	Load Curve 7	0 rpm 100%	
41C8	Load Curve 8	0 rpm 100%	
41C9	Load Curve 9	0 rpm 100%	

## Installation & Getting started

		Factory setting	Customer
420	Process Prot		
421	Low Volt OR	On	
422	Rotor Locked	Off	
423	Motor Lost	Off	
424	OverVolt Ctl	On	
425	OverflowPol	High	
426	Sensor lost	Off	
430	Person Prot		
431	PreAlarm	30min	
432	Alarm	5min	
440	User trips		
441	User trip 1		
4411	Action 1	No action	
4412	Delay 1	0s	
4413	Active pol 1	High	
4414	Autoreset 1	Off	
4415	Trip name 1	User defined	
4416	Trip text 1	User trip 1	
442	User trip 2		
4421	Action 2	No action	
4422	Delay 2	0s	
4423	Active pol 2	High	
4424	Autoreset 2	Off	
4425	Trip name 2	User defined	
4426	Trip text 2	User trip 2	
443	User trip 3		
4431	Action 3	No action	
4432	Delay 3	0s	
4433	Active pol 3	High	
4434	Autoreset 3	Off	
4435	Trip name 3	User defined	
4436	Trip text 3	User trip 3	
444	User trip 4		
4441	Action 4	No action	
4442	Delay 4	0s	
4443	Active pol 4	High	
4444	Autoreset 4	Off	
4445	Trip name 4	User defined	

# Installation & Getting started

			Factory setting	Customer
	4446	Trip text 4	User trip 4	
500	I/Os			
	510	An Inputs		
	511	AnIn1 Fc	Level sensor	
	512	AnIn1 Setup	4-20mA	
	513	AnIn1 Advn		
	5131	AnIn1 Min	4mA	
	5132	AnIn1 Max	20.00mA	
	5133	AnIn1 Bipol	20.00mA	
	5134	AnIn1 FcMin	Min	
	5135	AnIn1 VaMin	0	
	5136	AnIn1 FcMax	Max	
	5137	AnIn1 VaMax	0	
	5138	AnIn1 Oper	Add+	
	5139	AnIn1 Filt	0.1s	
	513A	AnIn1 Enabl	On	
	514	AnIn2 Fc	Off	
	515	AnIn2 Setup	4-20mA	
	516	AnIn2 Advan		
	5161	AnIn2 Min	4mA	
	5162	AnIn2 Max	20.00mA	
	5163	AnIn2 Bipol	20.00mA	
	5164	AnIn2 FcMin	Min	
	5165	AnIn2 VaMin	0	
	5166	AnIn2 FcMax	Max	
	5167	AnIn2 VaMax	0	
	5168	AnIn2 Oper	Add+	
	5169	AnIn2 Filt	0.1s	
	516A	AnIn2 Enabl	On	
	517	AnIn3 Fc	Off	
	518	AnIn3 Setup	4-20mA	
	519	AnIn3 Advan		
	5191	AnIn3 Min	4mA	
	5192	AnIn3 Max	20.00mA	
	5193	AnIn3 Bipol	20.00mA	
	5194	AnIn3 FcMin	Min	
	5195	AnIn3 VaMin	0	
	5196	AnIn3 FcMax	Max	

## Installation & Getting started

		Factory setting	Customer
	5197	AnIn3 VaMax	0
	5198	AnIn3 Oper	Add+
	5199	AnIn3 Filt	0.1s
	519A	AnIn3 Enabl	On
51A	AnIn4 Fc		Off
51B	AnIn4 Setup		4-20mA
51C	AnIn4 Advan		
	51C1	AnIn4 Min	4mA
	51C2	AnIn4 Max	20.00mA
	51C3	AnIn4 Bipol	20.00mA
	51C4	AnIn4 FcMin	Min
	51C5	AnIn4 VaMin	0
	51C6	AnIn4 FcMax	Max
	51C7	AnIn4 VaMax	0
	51C8	AnIn4 Oper	Add+
	51C9	AnIn4 Filt	0.1s
	51CA	AnIn4 Enabl	On
520	Dig Inputs		
	521	DigIn 1	Flow ManRun
	522	DigIn 2	Flow AutoRun
	523	DigIn 3	FlowLink In
	524	DigIn 4	Off
	525	DigIn 5	Off
	526	DigIn 6	Lvl overflow
	527	DigIn 7	Off
	528	DigIn 8	Reset
	529	B(oard)1 DigIn 1	Off
	52A	B(oard)1 DigIn 2	Off
	52B	B(oard)1 DigIn 3	Off
	52C	B(oard)2 DigIn 1	Off
	52D	B(oard)2 DigIn 2	Off
	52E	B(oard)2 DigIn 3	Off
	52F	B(oard)3 DigIn 1	Off
	52G	B(oard)3 DigIn 2	Off
	52H	B(oard)3 DigIn 3	Off
530	An Outputs		
	531	AnOut1 Fc	Frequency
	532	AnOut1 Setup	4-20mA

## Installation & Getting started

		Factory setting	Customer
533	AnOut1 Advan		
	5331	AnOut 1 Min	4mA
	5332	AnOut 1 Max	20.0mA
	5333	AnOut1Bipol	20.0mA
	5334	AnOut1 FcMin	Min
	5335	AnOut1 VaMin	0
	5336	AnOut1 FcMax	Max
	5337	AnOut1 VaMax	0
534	AnOut2 FC		Current
535	AnOut2 Setup		4-20mA
536	AnOut2 Advan		
	5361	AnOut 2 Min	4mA
	5362	AnOut 2 Max	20.0mA
	5363	AnOut2Bipol	20.0mA
	5364	AnOut2 FcMin	Min
	5365	AnOut2 VaMin	0
	5366	AnOut2 FcMax	Max
	5367	AnOut2 VaMax	0
540	Dig Outputs		
	541	DigOut 1	Ready
	542	DigOut 2	FlowLinkOut
550	Relays		
	551	Relay 1	Trip
	552	Relay 2	Running
	553	Relay 3	Off
	554	B(oard)1 Relay 1	Off
	555	B1 Relay 2	Off
	556	B1 Relay 3	Off
	557	B2 Relay 1	Off
	558	B2 Relay 2	Off
	559	B2 Relay 3	Off
	55A	B3 Relay 1	Off
	55B	B3 Relay 2	Off
	55C	B3 Relay 3	Off
55D	Relay Advan		
	55D1	Relay 1 Mode	N.O
	55D2	Relay 2 Mode	N.O
	55D3	Relay 3 Mode	N.O

# Installation & Getting started

		Factory setting	Customer	
	55D4	B1R1 Mode	N.O	
	55D5	B1R2 Mode	N.O	
	55D6	B1R3 Mode	N.O	
	55D7	B2R1 Mode	N.O	
	55D8	B2R2 Mode	N.O	
	55D9	B2R3 Mode	N.O	
	55DA	B3R1 Mode	N.O	
	55DB	B3R2 Mode	N.O	
	55DC	B3R3 Mode	N.O	
560	Virtual I/Os			
	561	VIO 1 Dest	Off	
	562	VIO 1 Source	Off	
	563	VIO 2 Dest	Off	
	564	VIO 2 Source	Off	
	565	VIO 3 Dest	Off	
	566	VIO 3 Source	Off	
	567	VIO 4 Dest	Off	
	568	VIO 4 Source	Off	
	569	VIO 5 Dest	Off	
	56A	VIO 5 Source	Off	
	56B	VIO 6 Dest	Off	
	56C	VIO 6 Source	Off	
	56D	VIO 7 Dest	Off	
	56E	VIO 7 Source	Off	
	56F	VIO 8 Dest	Off	
	56G	VIO 8 Source	Off	
600	Logical&Timers			
	610	Comparators		
	611	CA1 Setup		
		6111	CA1 Value	Speed
		6112	CA1 Level HI	300
		6113	CA1 Level LO	200
		6114	CA1 Type	Hysteresis
		6115	CA1 Polar	Unipolar
	612	CA2 Setup		
		6121	CA2 Value	Torque
		6122	CA2 LevelHI	20
		6123	CA2 LevelLO	10

## Installation & Getting started

		Factory setting	Customer
	6124	CA2 Type	Hysteresis
	6125	CA2 Polar	Unipolar
613	CA3 Setup		
	6131	CA3 Value	Process Val
	6132	CA3 LevelHI	30
	6133	CA3 LevelLO	20
	6134	CA3 Type	Hysteresis
	6135	CA3 Polar	Unipolar
614	CA4 Setup		
	6141	CA4 Value	Process Err
	6142	CA4 LevelHI	10
	6143	CA4 LevelLO	- 10
	6144	CA4 Type	Window
	6145	CA4 Polar	Bipolar
615	CD Setup		
	6151	CD1	Run
	6152	CD2	DigIn 1
	6153	CD3	Trip
	6154	CD4	Ready
620	Logic Y		
	621	Y Comp 1	CA1
	622	Y Operator 1	&
	623	Y Comp 2	!A2
	624	Y Operator 2	&
	625	Y Comp 3	CD1
630	Logic Z		
	631	Z Comp 1	CA1
	632	Z Operator 1	&
	633	Z Comp2	!A2
	634	Z Operator 2	&
	635	Z Comp 3	CD1
640	Timer1		
	641	Timer1 Trig	Off
	642	Timer1 Mode	Off
	643	Timer1 Delay	00:00:00
	644	Timer 1 T1	00:00:00
	645	Timer1 T2	00:00:00
	649	Timer1 Value	00:00:00

## Installation & Getting started

		Factory setting	Customer
650	Timer2		
651	Timer2 Trig	Off	
652	Timer2 Mode	Off	
653	Timer2 Delay	00:00:00	
654	Timer 2 T1	00:00:00	
655	Timer2 T2	00:00:00	
659	Tmer2 Value	00:00:00	
660	Counters		
661	Counter 1		
6611	C1 Trig	Off	
6612	C1 Reset	Off	
6613	C1 High Val	0	
6614	C1 Low Val	0	
6615	C1 DecTimer	Off	
6619	C1 Value	0	
662	Counter 2		
6621	C2 Trig	Off	
6622	C2 Reset	Off	
6623	C2 High Val	0	
6624	C2 Low Val	0	
6625	C2 DecTimer	Off	
6629	C2 Value	0	
670	Clock logic		
671	Clock 1		
6711	Clk 1 TimeOn	00:00:00	
6712	Clk 1 TimeOff	00:00:00	
6713	Clk 1 DateOn	2013-01-01	
6714	Clk 1 DateOff	2013-01-01	
6715	Clk 1 Weekday	MTWTFSS	
672	Clock 2		
6721	Clk 2 TimeOn	00:00:00	
6722	Clk 2 TimeOff	00:00:00	
6723	Clk 2 DateOn	2013-01-01	
6724	Clk 2 DateOff	2013-01-01	
6725	Clk 2 Weekday	MTWTFSS	

# Installation & Getting started

		Factory setting	Customer
700	Oper/Status		
710	Operation		
712	Speed		
713	Torque		
714	Shaft Power		
715	El Power		
716	Current		
717	Output volt		
718	Frequency		
719	DC Voltage		
71A	Heatsink Tmp		
71B	PT100_1_2_3		
720	Status		
721	VSD Status		
722	Warning		
723	Warning P2		
724	DigIn Status		
725	DigOutStatus		
726	AnIn 1 2		
727	AnIn 3 4		
728	AnOut 1 2		
729	IO Status B1		
72A	IO Status B2		
72B	IO Status B3		
72C	Area D Stat		
	72C1	Area D LSB	
	72C2	Area D MSB	
72D	VIO Status		
730	Stored Val		
731	Run Time		
	7311	RunTime Tot	
	7312	P1 Run Time	00:00:00
	7313	P2 Run Time	00:00:00
	7314	RunTime Day	
	7315	P1 RunT Day	00:00:00
	7316	P2 RunT Day	00:00:00
732	Mains Time	00:00:00	
733	Energy		

## Installation & Getting started

		Factory setting	Customer
7331	Energy tot	...kWh	
7332	Energy P1	...kWh	
7333	Energy P2	...kWh	
7334	Energy Day		
7335	P1EnergyDay		
7336	P2EnergyDay		
734	Pump starts		
7341	Pstarts tot		
7342	P1 starts P2 starts		
7344	StartsToday		
7345	P1StartsDay P2StartsDay		
736	EnergySaving		
737	Overflow		
7371	LastDurTime	00:00:00	
7373	TotDurTime	00:00:00	
740	Flow Status		
741	Sump level		
742	Inflow		
743	Outflow		
7431	Outflow Tot		
7432	Outflow P1		
7433	Outflow P2		
7434	NetFlow		
744	Pumped vol		
7441	Vol pumped		
7442	P1 Volume		
7443	P2 Volume		
7444	VolumeDaily		
7445	P1Vol Daily		
7446	P2Vol Daily		
745	Frequency		
746	Pump mode	Off	
747	Current	Off	
74A	FlowState		
750	BEP Status		
751	BEP state		
752	BEPprogress		

# Installation & Getting started

		Factory setting	Customer
753	BEP Aborts		
	7531	AbortReason	
	7532	UnevenFlow	
	7533	PrePostFlow	
	7534	CalcSave	
	7535	NoRefFlow	
	7536	RuntimeLow	
	7537	NoPostFlow	
	7538	NoPreFlow	
800	View TripLog		
810	Trip Message (log list 1)		
811	Operation		
	8111	Process Val	
	8112	Speed	
	8113	Torque	
	8114	Shaft Power	
	8115	El Power	
	8116	Current	
	8117	Output volt	
	8118	Frequency	
	8119	DC Voltage	
	811A	HeatsinkTmp	
	811B	PT100 1,2,3	
	812	Speed	
8121		VSD Status	
8123		Warning P2	
8124		DigInStatus	
8125		DigOutStat	
8126		AnIn 1 2	
8127		AnIn 3 4	
8128		AnOut1 2	
8129		IO StatusB1	
812A		IO StatusB2	
812B		IO StatusB3	
813		Stored Val	
	8131	P1 Run Time	
	8132	Mains Time	
	8133	Energy P1	

## Installation & Getting started

		Factory setting	Customer
	8134	Pstarts tot	
	8135	Pump starts	
	8136	Time	
	8137	Date	
814	Flow Status		
	8141	Sump level	
	8142	Pump mode	
	8143	Flow state	
	8144	BEP state	
820	Trip Message 821- 8244(log list 2)		
830	Trip Message 831 - 8344 (log list 3)		
840	Trip Message 841 - 8444 (log list 4)		
850	Trip Message 851 - 8544 (log list 5)		
860	Trip Message 861 - 8644 (log list 6)		
870	Trip Message 871 - 8744 (log list 7)		
880	Trip Message 881 - 8844 (log list 8)		
890	Trip Message 891 - 8944 (log list 9)		
8A0	Reset Trip L	No	
900	System Data		
920	VSD Data		
	921	VSD Type	
	922	Software	
		9221 Build Info	
		9222 Build ID	
	923	Unit name	0
	924	Bluetooth ID	
930	Clock		
	931	Time	00:00:00
	932	Date	13-01-01
	933	Weekday	Monday
940	Flow log 1P		
	941	Valid points	0
	942	Freq: XX.x Hz	
		9421 Outflow	0lit/s
		9422 Flow energy	0Wh
		9423 DataMeasured	0
	943	Freq: XX.x Hz + submenus 9431 - 9433	

## Installation & Getting started

		Factory setting	Customer
944	Freq: XX.x Hz + submenus 9441 - 9443		
945	Freq: XX.x Hz + submenus 9451 - 9453		
946	Freq: XX.x Hz + submenus 9461 - 9463		
947	Freq: XX.x Hz + submenus 9471 - 9473		
948	Freq: XX.x Hz + submenus 9481 - 9483		
949	Freq: XX.x Hz + submenus 9491 - 9493		
94A	Freq: XX.x Hz + submenus 94A1 - 94A3		
94B	Freq: XX.x Hz + submenus 94B1 - 94B3		
94C	Freq: XX.x Hz + submenus 94C1 - 94C3		
94D	Freq: XX.x Hz + submenus 94D1 - 94D3		
94E	Freq: XX.x Hz + submenus 94E1 - 94E3		
94F	Freq: XX.x Hz + submenus 94F1 - 94F3		
94G	Freq: XX.x Hz + submenus 94G1 - 94G3		
94H	Freq: XX.x Hz + submenus 94H1 - 94H3		
94I	Freq: XX.x Hz + submenus 94I1 - 94I3		
94J	Freq: XX.x Hz + submenus 94J1 - 94J3		
94K	Freq: XX.x Hz + submenus 94K1 - 94K3		
950	Flow log 2P		
951	Valid points	0	
952 - 95K same menus as 943 - 94K for Pump 2			
990	Reset		
991	Reset Energy	No	
992	Savings	No	
993	Reset Volume	No	
994	Reset starts	No	
995	Daily Reset	No	
996	Overflow	No	
997	Reset runtime	No	



**CG Drives & Automation Sweden AB**

Mörsaregatan 12

Box 222 25

SE-250 24 Helsingborg

Sweden

T +46 42 16 99 00

F +46 42 16 99 49

[www.emotron.com/www.cgglobal.com](http://www.emotron.com/www.cgglobal.com)