



# Emotron VFX 2.1 AC drive



Instruction manual

English

Valid from software version 5.1x

**emotron**

DEDICATED DRIVE

 | A CG Product



# **Emotron VFX 2.1**

## **INSTRUCTION MANUAL - ENGLISH**

Valid from Software version 5.1x

Document number: 01-7492-01

Edition: r2

Date of release: 2026-03-26

© Copyright CG Drives & Automation Sweden AB 2005 - 2023

CG Drives & Automation Sweden AB retains the right to change specifications and illustrations in the text, without prior notification. The contents of this document may not be copied without the explicit permission of CG Drives & Automation Sweden AB.



# Safety Instructions

Congratulations for choosing a product from CG Drives & Automation!

Before you begin with installation, commissioning or powering up the unit for the first time it is very important that you carefully study this Instruction manual. Following symbols can appear in this instruction or on the product itself. Always read these first before continuing.

---

**NOTE: Additional information as an aid to avoid problems.**

---



**CAUTION!**  
Failure to follow these instructions can result in malfunction or damage to the AC drive.

---



**Warning!**  
Failure to follow these instructions can result in serious injury to the user in addition to serious damage to the AC drive.

---



**HOT SURFACE!**  
Failure to follow these instructions can result in injury to the user.

---

## Handling the AC drive

Installation, commissioning, demounting, taking measurements, etc, of or on the AC drive may only be carried out by personnel technically qualified for the task. A number of national, regional and local regulations govern handling, storage and installation of the equipment. Always observe current rules and legislation.

## Opening the AC drive



**WARNING!**  
Always switch off the mains voltage before opening the AC drive and wait at least 7 minutes to allow the capacitors to discharge.

---

Always take adequate precautions before opening the AC drive. Although the connections for the control signals and the switches are isolated from the main voltage, do not touch the control board when the AC drive is switched on.

## Incorrect connection

The AC drive is not protected against incorrect connection of the mains voltage, and in particular against connection of the mains voltage to the motor outlets U, V and W. The AC drive can be damaged in this way. Risk for personal injury.

## Precautions to be taken with a connected motor

If work must be carried out on a connected motor or on the driven machine, the mains voltage must always be disconnected from the AC drive first. Wait at least 7 minutes before starting work.

## Earthing

The AC drive must always be earthed via the mains safety earth connection.

## Earth leakage current



**CAUTION!**  
This AC drive has an earth leakage current which does exceed 3.5 mA AC. Therefore the minimum size of the protective earth conductor on the supply side must comply with the local safety regulations for high leakage current equipment which means that according to the standard IEC61800-5-1 the protective earth connection must be assured by one of following conditions:

PE conductor cross-sectional area shall for phase cable size  $\leq 16 \text{ mm}^2$  (6 AWG) be  $>10 \text{ mm}^2$  Cu ( $16 \text{ mm}^2$  Al) or use a second PE conductor with same area as original PE conductor.

For cable size above  $16 \text{ mm}^2$  (6 AWG) but smaller or equal to  $35 \text{ mm}^2$  (2 AWG) the PE conductor cross-sectional area shall be at least  $16 \text{ mm}^2$  (6 AWG).

For cables  $>35 \text{ mm}^2$  (2 AWG) the PE conductor cross-sectional area should be at least 50 % of the used phase conductor.

When the PE conductor in the used cable type is not in accordance with the above mentioned cross-sectional area requirements, a separate PE conductor should be used to establish this.

---

## Residual current device (RCD) compatibility

This product can cause a DC current in the protective earthing conductor. Where a residual current-operated protective device (RCD) or a monitoring device (RCM) is used for protection in case of direct or indirect contact, only a Type B RCD/RCM is allowed on the supply side of this product. Use RCD of 300 mA minimum.

## EMC Regulations

In order to comply with the EMC Directive, it is absolutely necessary to follow the installation instructions. All installation descriptions in this manual follow the EMC Directive.

## Mains voltage selection

The AC drive may be ordered for use with the mains voltage range listed below.

VFX48: 230-480 V

VFX52: 440-525 V

VFX69: 500-690 V

## Voltage tests (Megger)

Do not carry out voltage tests (Megger) on the motor, before all the motor cables have been disconnected from the AC drive.

## Condensation

If the AC drive is moved from a cold (storage) room to a room where it will be installed, condensation can occur. This can result in sensitive components becoming damp. Do not connect the mains voltage until all visible dampness has evaporated.

## Power factor capacitors for improving $\cos\phi$

Remove all capacitors from the motor and the motor outlet.

## Precautions during Autoreset

When the automatic reset is active, the motor will restart automatically provided that the cause of the trip has been removed. If necessary take the appropriate precautions.

## Transport

To avoid damage, keep the AC drive in its original packaging during transport. This packaging is specially designed to absorb shocks during transport.

## IT Mains supply

The AC drives can be modified for an IT mains supply, (non-earthed neutral), please contact your supplier for details.

## Alarms

Never disregard an alarm. Always check and remedy the cause of an alarm.

## Heat warning



**HOT SURFACE!**

Be aware of specific parts on the AC drive having high temperature.

---

## DC-link residual voltage



**WARNING!**

After switching off the mains supply, dangerous voltage can still be present in the AC drive. When opening the AC drive for installing and/or commissioning

activities wait at least 7 minutes. In case of malfunction a qualified technician should check the DC-link or wait for one hour before dismantling the AC drive for repair.

---

## Communication Fault

The default setting for communication supervision is **OFF** which means no action will be taken if a COMM error occurs and a Fieldbus fault is detected.

If supervision is required, adjust the settings in parameters [2641] and [2643].

# Contents

<b>Safety Instructions .....</b>	<b>1</b>
<b>Contents .....</b>	<b>3</b>
<b>1. Introduction.....</b>	<b>7</b>
1.1 Delivery and unpacking .....	7
1.2 Using of the instruction manual .....	7
1.2.1 Instruction manuals for optional equipment.....	7
1.3 Warranty .....	8
1.4 Type code number.....	8
1.5 Standards .....	10
1.5.1 Product standard for EMC .....	10
1.6 Dismantling and scrapping.....	12
1.6.1 Disposal of old electrical and electronic equipment .....	12
1.7 Glossary .....	12
1.7.1 Abbreviations and symbols.....	12
1.7.2 Definitions.....	12
<b>2. Mounting.....</b>	<b>13</b>
2.1 Lifting instructions.....	13
2.2 Stand-alone units .....	17
2.2.1 Cooling .....	17
2.2.2 Mounting schemes.....	18
2.3 Cabinet mounting.....	25
2.3.1 Cooling .....	25
2.3.2 Recommended free space in front of cabinet .....	25
2.3.3 Mounting schemes, cabinets .....	26
<b>3. Installation .....</b>	<b>29</b>
3.1 Before installation .....	29
3.1.1 Remove/open front cover .....	29
3.1.2 Remove/open the lower front cover on Frame size E2, F2 and FA2 (IP20/21).....	30
3.2 Cable connections for small and medium frame sizes .....	30
3.2.1 Mains cables .....	30
3.2.2 Motor cables.....	33
3.3 Connection of motor and mains cables for larger frame sizes.....	35
3.3.1 Connection of mains and motor cables on IP20 modules .....	38
3.4 Cable specifications.....	39
3.4.1 Stripping lengths .....	39
3.4.2 Fuse data.....	41
3.4.3 Cable connection data for mains, motor and PE cables according to IEC ratings.....	42
3.4.4 Cable connection data for mains, motor and PE cables according to NEMA ratings .....	46
3.5 Thermal protection on the motor .....	48
3.6 Motors in parallel .....	48
<b>4. Control Connections.....</b>	<b>49</b>
4.1 Control board.....	49
4.2 Terminal connections .....	50
4.2.1 Stand by supply interface (SBS).....	51
4.3 Configuration with jumpers and switches .....	51
4.3.1 Analogue input configuration (S1 - S4).....	51
4.3.2 RS-485 termination (S5) .....	52
4.4 Connection example .....	53
4.5 Connecting the control signals.....	54
4.5.1 Cables .....	54
4.5.2 Types of control signals .....	56
4.5.3 Screening.....	56
4.5.4 Single-ended or double-ended connection? .....	56
4.5.5 Current signals ((0)4-20 mA).....	57
4.5.6 Twisted cables.....	57
4.6 Connecting options .....	57
<b>5. Getting Started.....</b>	<b>59</b>
5.1 Connect the mains and motor cables .....	59
5.1.1 Mains cables .....	59
5.1.2 Motor cables.....	59
5.2 Using the function keys .....	60
5.3 Remote control.....	60
5.3.1 Connect control cables .....	60
5.3.2 Switch on the mains .....	60
5.3.3 Set the Motor Data.....	61
5.3.4 Run the AC drive.....	61
5.4 Local control .....	61
5.4.1 Switch on the mains .....	61
5.4.2 Select manual control.....	61
5.4.3 Set the Motor Data.....	61
5.4.4 Enter a Reference Value.....	61
5.4.5 Run the AC drive.....	61
<b>6. Applications.....</b>	<b>63</b>
6.1 Application overview .....	63
6.1.1 Cranes.....	63
6.1.2 Crushers.....	63
6.1.3 Mills.....	64
6.1.4 Mixers .....	64
<b>7. Main Features .....</b>	<b>65</b>
7.1 Parameter sets.....	65
7.1.1 Define parameter sets.....	65
7.1.2 Select and copy parameter set .....	65
7.1.3 One motor and one parameter set .....	66
7.1.4 One motor and two parameter sets.....	66
7.1.5 Two motors and two parameter sets .....	66
7.1.6 Autoreset at trip .....	66
7.1.7 Reference priority.....	67
7.1.8 Preset references.....	67
7.2 Remote control functions .....	67
7.2.1 Default settings of the Run/Stop/Enable/Reset functions .....	67
7.3 Performing an Identification Run .....	70
7.4 Using the Control Panel Memory.....	70
7.5 Load Monitor and Process Protection [400].....	71
7.5.1 Load Monitor [410].....	71
7.6 Emotron Dedicated Pump [390].....	73
7.6.1 Introduction .....	73
7.6.2 Fixed MASTER .....	74
7.6.3 Alternating MASTER .....	74

7.6.4	Feedback 'Status' input .....	74	11.3	Process and Application Parameters [300] .....	132
7.6.5	Fail safe operation .....	75	11.3.1	Set/View Reference Value [310] .....	132
7.6.6	PID control .....	76	11.3.2	Process Settings [320] .....	133
7.6.7	Wiring Alternating Master .....	77	11.3.3	Start/Stop settings [330] .....	136
7.6.8	Checklist and tips.....	78	11.3.4	Mechanical brake control.....	140
7.6.9	Functional Examples of Start/Stop Transitions ....	79	11.3.5	Speed [340] .....	144
7.7	Pump and fan control [391].....	81	11.3.6	Torques [350].....	146
7.8	Pump cleaning [392] .....	81	11.3.7	Preset References [360] .....	148
7.8.1	Load monitor - automatic detection .....	81	11.3.8	PI Speed Control [370] .....	150
7.8.2	Different ways a pump can get clogged .....	82	11.3.9	PID Process Control [380].....	151
<b>8.</b>	<b>EMC and standards .....</b>	<b>83</b>	11.3.10	Emotron Dedicated Pump 390 .....	154
8.1	EMC standards .....	83	11.3.11	Crane Option [3A0] .....	161
8.2	Stop categories and emergency stop .....	83	11.4	Load Monitor and Process Protection [400].....	165
<b>9.</b>	<b>Communication .....</b>	<b>85</b>	11.4.1	Load Monitor [410].....	165
9.1	Modbus RTU .....	85	11.4.2	Process Protection [420].....	169
9.2	Parameter sets.....	85	11.4.3	Trip text [430].....	170
9.3	Motor data .....	86	11.5	I/Os and Virtual Connections [500].....	171
9.4	Start and stop commands.....	86	11.5.1	Analogue Inputs [510] .....	171
9.5	Reference signal .....	86	11.5.2	Digital Inputs [520].....	177
9.5.1	Process value .....	86	11.5.3	Analogue Outputs [530] .....	179
9.6	Description of the Elnt formats .....	87	11.5.4	Digital Outputs [540] .....	182
9.7	32-bit read/write support .....	89	11.5.5	Relays [550] .....	185
<b>10.</b>	<b>Operation via the</b>		11.5.6	Virtual Connections [560] .....	186
	<b>Control Panel .....</b>	<b>91</b>	11.6	Logical Functions and Timers [600] .....	186
10.1	General .....	91	11.6.1	Comparators [610] .....	186
10.2	Control panel with 4-line display.....	91	11.6.2	Analogue Multiplexer [620].....	192
10.2.1	The display.....	91	11.6.3	Not Gate [630] .....	194
10.2.2	Menu [100] Start Window .....	93	11.6.4	Logic output [640] .....	194
10.2.3	Editing mode.....	93	11.6.5	Timers [650].....	197
10.2.4	Fault logger.....	94	11.6.6	Flip flops [660] .....	199
10.2.5	Real Time clock .....	94	11.6.7	Counters [670].....	201
10.2.6	LED indicators .....	94	11.6.8	Clock Logic [680] .....	203
10.2.7	Control keys.....	94	11.7	View Operation/Status [700] .....	204
10.2.8	The Toggle and Loc/Rem Key .....	95	11.7.1	Operation [710].....	204
10.2.9	Function keys .....	96	11.7.2	Status [720] .....	205
10.3	The menu structure.....	96	11.7.3	Stored values [730] .....	209
10.3.1	The main menu .....	97	11.8	View Trip Log [800] .....	210
10.4	Programming during operation .....	97	11.9	System Data [900].....	212
10.5	Editing values in a menu .....	97	11.9.1	VSD Data [920] .....	212
10.6	Copy current parameter to all sets .....	98	11.9.2	Real Time clock .....	214
10.7	Programming example.....	98	11.9.3	Inspection [940].....	214
<b>11.</b>	<b>Functional description .....</b>	<b>99</b>	11.9.4	Service cont [950].....	215
11.1	Menus .....	99	<b>12.</b>	<b>Troubleshooting, Diagnoses and</b>	
11.1.1	Description of menu table layout.....	99		<b>Maintenance .....</b>	<b>217</b>
11.1.2	Resolution of settings .....	100	12.1	Trips, warnings and limits.....	217
11.1.3	1st Line [110].....	100	12.2	Trip conditions, causes and remedial action .....	218
11.2	Main Setup [200].....	101	12.2.1	Technically qualified personnel.....	219
11.2.1	Operation .....	101	12.2.2	Opening the AC drive .....	219
11.2.2	Motor Data [220] .....	106	12.2.3	Precautions to take with a connected motor .....	219
11.2.3	Motor Protection [230] .....	113	12.2.4	Autoreset Trip .....	219
11.2.4	Parameter Set Handling [240].....	116	12.3	Maintenance .....	224
11.2.5	Trip Autoreset/Trip Conditions [250].....	119	<b>13.</b>	<b>Options.....</b>	<b>225</b>
11.2.6	Serial Communication [260] .....	125	13.1	Control panel .....	225
11.2.7	Wireless [270].....	129	13.2	External control panel kits.....	225
			13.2.1	Control panel kit, including blank panel.....	225

13.2.2	Control panel kit, including control panel.....	225
13.3	Handheld Control Panel 2.0 .....	226
13.4	Gland kits.....	226
13.5	EmoSoftCom.....	226
13.6	EmoDrive App .....	226
13.7	Brake chopper.....	227
13.8	I/O Board .....	228
13.9	Encoder.....	228
13.10	PTC/PT100 .....	228
13.11	Crane option board .....	229
13.12	Communication options.....	229
13.13	Safe Torque Off (STO) .....	229
13.14	EMC filter class C1/C2 .....	229
13.15	Output chokes .....	229
13.16	Liquid cooling .....	229
13.17	Top cover for IP20/21 version .....	230
13.18	Other options.....	230
13.19	AFE - Active Front End.....	230
<b>14.</b>	<b>Technical Data .....</b>	<b>231</b>
14.1	Electrical specifications related to model .....	231
14.2	General electrical specifications.....	238
14.3	Operation at higher temperatures .....	239
14.3.1	Possible derating.....	239
14.4	Dimensions and Weights.....	240
14.5	Environmental conditions.....	243
14.6	Fuses and glands .....	244
14.6.1	According to IEC ratings.....	244
14.6.2	Fuses according to NEMA ratings .....	248
14.7	Control signals.....	249
<b>15.</b>	<b>Menu List.....</b>	<b>251</b>
<b>16.</b>	<b>EcoDesign product information per EU Directive 2019/1781 .....</b>	<b>283</b>
16.1	EcoDesign data for 400 V - IP20 and IP54 drive units .....	283
16.2	EcoDesign data for 400 V - IP54 drive units .....	284
16.3	EcoDesign data for 525 V - IP54 drive units .....	285
16.4	EcoDesign data for 690 V - IP20 and IP54 drive units .....	286
	<b>Index .....</b>	<b>287</b>



# 1. Introduction

Emotron VFX is intended for controlling the speed and torque of standard three phase asynchronous electrical motors. The AC drive (Frequency converter) is equipped with direct torque control which uses built-in digital signal processor - DSP, giving the AC drive the capability of high dynamic performance even at very low speeds without using feedback signals from the motor. Therefore the inverter is designed for use in high dynamic applications where low speed high torque and high-speed accuracy are demanded. In “simpler” application such as fans or pumps, the VFX direct torque control offers other great advantages such as insensitivity to mains disturbances or load shocks. Several options are available, listed in Chapter 13. page 225, that enable you to customize the AC drive for your specific needs.

---

**NOTE: Read this instruction manual carefully before starting installation, connection or working with the AC drive.**

---

## Users

This instruction manual is intended for:

- installation engineers
- maintenance engineers
- service engineers

## Motors

The AC drive is suitable for use with standard 3-phase asynchronous motors. Under certain conditions it is possible to use other types of motors. Contact your supplier for details.

## 1.1 Delivery and unpacking

Check for any visible signs of damage. Inform your supplier immediately of any damage found. Do not install the AC drive if damage is found.

Check that all items are present and that the type number is correct.

## 1.2 Using of the instruction manual

Within this instruction manual the abbreviation “AC drive” is used to indicate the complete variable speed drive as a single unit.

Check that the software version number on the first page of this manual matches the software version in the AC drive. See Section 11.9.1 page 212.

With help of the index and the table of contents it is easy to track individual functions and to find out how to use and set them.

The Quick Setup Card can be put in a cabinet door, so that it is always easy to access in case of an emergency.

## 1.2.1 Instruction manuals for optional equipment

In the following table we have listed available options and the name of the Instruction manual or data sheet/ Instruction plus document number. Further in this main manual we are often referring to these instructions.

*Table 1 Available options and documents*

Option	Valid instruction manual/ document number
I/O board	I/O board 2.0, instruction manual / 01-5916-01
Encoder board	Emotron Encoder board 2.0, Instruction manual / 01-5917-01
PTC/PT100 board	PTC/PT100 board 2.0, instruction manual / 01-5920-01
I/O interface 24V (for cranes)	Emotron AC Drive Crane option 2.0, Instruction manual
I/O interface 230V (for cranes)	
Fieldbus - Profibus	Fieldbus Option, Instruction manual / 01-3698-01
Fieldbus - DeviceNet	
Fieldbus - CANopen	
Ethernet - Modbus TCP	
Ethernet - EtherCAT	
Ethernet - Profinet IO 1-port	
Ethernet - Profinet IO 2-port	
Ethernet - EtherNet/IP 2-port	
Ethernet - Profinet IO S2, 2-port M40	
RS232/RS485 isolated	Emotron isolated RS232 / 485 2.0 option Instruction manual / 01-5919-01
Control panel kit, Incl blank panel	Emotron FDU/VFX 2.0 External Control Panel, instruction manual / 01-5928-01
Control panel kit, Incl control panel	
Handheld Control Panel HCP2.0	Emotron HCP 2.0, instruction manual / 01-5925-01
OSTO_100 option board	Emotron OSTO_100 Safe Torque Off (STO) Instruction manual / 01-7513-11
Overshoot clamp	Overshoot clamp Datasheet/Instruction / 01-5933-11
Liquid cooling	Emotron FDU/VFX 2.0 Liquid Cooling, instruction manual / 01-4636-01
Output choke	Output coils Datasheet/Instruction / 01-3132-11
AFE- Active front end	Emotron VFX/VDU 2.0 AFE- Active Front End option, Instruction manual / 01-5386-01

Table 1 Available options and documents

Option	Valid instruction manual/ document number
EmoDrive App	EmoDrive App Instruction manual / 01-7776-01

The code number is located on the product label, on the unit.

New type code for all FDU/VFX drive sizes (002-3K0), valid from 2021-01-01 (serial no from: PPPPRR2101SSSS\*).

### 1.3 Warranty

The warranty applies when the equipment is installed, operated and maintained according to instructions in this instruction manual. Duration of warranty as per contract. Faults that arise due to faulty installation or operation are not covered by the warranty.

### 1.4 Type code number

Fig. 1 gives an example of the type code numbering used on all AC drives. With this code number the exact type of the drive can be determined. This identification will be required for type specific information when mounting and installing.

Type code	VFX	48	-017	-20	C	E	-	-	-	A	-	N	N	N	N	A	N	-	-	A
Position No	1	2	3	4	5	6	7	8	9	10	11	12	13	14	15	16	17	18	19	20

Fig. 1 Type code number

Position for 002-3K0	Configuration	
1	AC drive type	VFX
2	Supply voltage	48=480 V mains 52=525 V mains 69=690 V mains
3	Rated current (A) continuous	-002=2.0 A - -3K0=3000 A
4	Protection class	20=IP20 - Intended for mounting inside a cabinet 21=IP21 - Intended for wall-mounting 54=IP54 - Intended for wall-mounting
5	Control panel	--=Blank panel D=4-line Control panel, standard IP2X/54 E=4-line Control panel with Bluetooth (option IP2X/54) F=4-line Control panel with WiFi (option IP2X/54)
6	EMC option	E=Standard EMC (Category C3) F=Extended EMC (Category C2) I=IT-Net
7	Brake chopper option	--=No chopper B=Chopper built in D=DC+/- interface
8	Stand-by power supply option	--=No SBS (24V input included in Control board 2.1) S=SBS included (code not used with Control board 2.1)
9	Safe Torque Off option	--=No Safe Torque Off O=Safe Torque Off included
10	Brand label	A=Standard
11	Coated boards, option	--=Standard, not coated boards IP54 V=Coated boards, option IP54 (standard IP2X)

Position for 002-3K0	Configuration	
12	Option position 1	N=No option C=Crane I/O (max. 1) E=Encoder (max. 1) P=PTC/PT100 (max. 2) I=Extended I/O (max. 3)
13	Option position 2	
14	Option position 3	
15	Option position, communication	N= No option D= DeviceNet P= Profibus S= RS232/485 M= Modbus/TCP 1-port H= Modbus/TCP 2-port E= EtherCAT A= Profinet IO 1-port B= Profinet IO 2-port G= EtherNet/IP 2-port C= CANopen J=Profinet IO S2, 2-port M40
16	Software type	A= Standard software
17	Motor PTC. (Only valid for 002-105/B-D2(69))	N= No option P= PTC
18	Gland kit. (Only valid for 002-074/IP54)	-- Glands not included G= Gland kit included
19	Approval/certification	-- CE approved D= Marine DNV Product certificate (above 100 kW) + CE approved M= Marine version + CE approved U=UL/cUL approved
20	Painted AC drive	A=Standard paint

\*) Serial no coding: PPPPRRYWWSSSS

PPPP = Manufacturing plant

RR = Product revision no

YY = Manufacturing year

WW = Manufacturing week

SSSS = Serial no

E.g. 18410121010001

## 1.5 Standards

The AC drives described in this instruction manual comply with the standards listed in Table 2. For the declarations of conformity and manufacturer's certificate, contact your supplier for more information or visit [www.emotron.com/](http://www.emotron.com/) [www.cgglobal.com](http://www.cgglobal.com).

### 1.5.1 Product standard for EMC

Product standard EN IEC 61800-3:2018.

**First Environment** (Extended EMC) as environment that includes domestic premises. It also includes establishments directly connected without intermediate transformers to a low voltage power supply network that supplies buildings used for domestic purposes.

Category C2: Power Drive System (PDS) of rated voltage <1.000 V, which is neither a plug in device nor a movable device and, when used in the first environment, is intended to be installed and commissioned only by a professional.

**Second environment** (Standard EMC) includes all other establishments.

Category C3: PDS of rated voltage <1.000 V, intended for use in the second environment and not intended for use in the first environment.

Category C4: PDS or rated voltage equal or above 1.000 V, or rated current equal to or above 400 A, or intended for use in complex systems in the second environment.

The AC drive complies with the product standard EN IEC 61800-3:2018 (Any kind of metal screened cable may be used). The standard AC drive is designed to meet the requirements according to category C3, for a motor cable length of maximum 80 m.

By using the optional "Extended EMC" filter the AC drive fulfils requirements according to category C2.



**WARNING!**

In a domestic environment this product may cause radio interference, in which case it may be necessary to take adequate additional measures.



**WARNING!**

The standard AC drive, complying with category C3, is not intended to be used on a low-voltage public network which supplies domestic premises; radio interference is expected if used in such a network. Contact your supplier if you need additional measures.

---

Table 2 Standards

Market	Standard	Description
European	EMC Directive	2014/30/EU
	Low Voltage Directive	2014/35/EU
	WEEE Directive	2012/19/EU
	Ecodesign Directive	2009/125/EC
	RoHS II Directive	2011/65/EU
	RED Directive	2014/53/EU
Great Britain (England, Scotland, Wales) UKCA	ECR	Electromagnetic Compatibility Regulations - 2016/1091
	EESR	Electrical Equipment (Safety) Regulations - 2016/1101
	EERPEI	Ecodesign for Energy-Related Products and Energy Information Regulation - 2021/745
	RUCHSEEE	Restriction of the Use of Certain Hazardous Substances in Electrical and Electronic Equipment - 2012/3032
	RER	Radio Equipment Regulations - 2017/1206
All	EN 60204-1:2018	Safety of machinery - Electrical equipment of machines Part 1: General requirements.
	EN IEC 61800-3:2018	Adjustable speed electrical power drive systems Part 3: EMC requirements and specific test methods. <b>EMC Directive: Declaration of Conformity and CE marking</b>
	EN(IEC)61800-5-1:2007 + A1:2017 + A11:2021	Adjustable speed electrical power drive systems Part 5-1. Safety requirements - Electrical, thermal and energy. <b>Low Voltage Directive: Declaration of Conformity and CE marking</b>
	IEC 60721-3-3:2019	Classification of environmental conditions. Air quality chemical vapours, unit in operation. Chemical gases 3C2, Solid particles 3S2. Optional with coated boards Unit in operation. Chemical gases Class 3C3, Solid particles 3S2.
	EN 50581:2012	Restriction of hazardous substances
North & South America	ULC508C	UL Safety standard for Power Conversion Equipment
	USL	USL (United States Standards - Listed) complying with the requirements of UL508C Power Conversion Equipment
	UL 840	UL Safety standard for Power Conversion Equipment. Insulation coordination including clearances and creepage distances for electrical equipment.
	CNL	CNL (Canadian National Standards - Listed) complying with the requirements of CAN/CSA C22.2 No. 14-10 Industrial Control Equipment.
Russian	EAC	For all sizes.

## 1.6 Dismantling and scrapping

The enclosures of the drives are made from recyclable material as aluminium, iron and plastic. Our AC-drives comply to RoHS II directive, and contain electronic waste (e-waste). Any local or national regulations in force for the disposal and recycling of e-waste must be complied with.

### 1.6.1 Disposal of old electrical and electronic equipment



This symbol on the product or on its packaging indicates that this product shall be taken to the applicable collection point for the recycling of electrical and electronic equipment. By ensuring this product is disposed of correctly, you will help prevent potentially negative consequences for the environment and human health, which could otherwise be caused by inappropriate waste handling of this product. The recycling of materials will help to conserve natural resources. For more detailed information about recycling this product, please contact the local distributor of the product.

## 1.7 Glossary

### 1.7.1 Abbreviations and symbols

In this manual the following abbreviations are used:

Table 3 Abbreviations

Abbreviation/symbol	Description
DSP	Digital signals processor
AC drive	Frequency converter
PEBB	Power Electronic Building Block
IGBT	Insulated Gate Bipolar Transistor
CP	Control panel, the programming and presentation unit on the AC drive
HCP	Handheld control panel (option)
Elnt	Communication format
Uln	Communication format (Unsigned integer)
ln	Communication format (Integer)
Long	Communication format
SELV	Safety Extra Low Voltage
	The function cannot be changed in run mode

### 1.7.2 Definitions

In this manual the following definitions for current, torque and frequency are used:

Table 4 Definitions

Name	Description	Quantity
$I_{IN}$	Nominal input current of AC drive	$A_{RMS}$
$I_{NOM}$	Nominal output current of AC drive	$A_{RMS}$
$I_{MOT}$	Nominal motor current	$A_{RMS}$
$P_{NOM}$	Nominal power of AC drive	kW
$P_{MOT}$	Motor power	kW
$T_{NOM}$	Nominal torque of motor	Nm
$T_{MOT}$	Motor torque	Nm
$f_{OUT}$	Output frequency of AC drive	Hz
$f_{MOT}$	Nominal frequency of motor	Hz
$n_{MOT}$	Nominal speed of motor	rpm
$I_{CL}$	Maximum output current	$A_{RMS}$
Speed	Actual motor speed	rpm
Torque	Actual motor torque	Nm
Sync speed	Synchronous speed of the motor	rpm

## 2. Mounting

This chapter describes how to mount the AC drive.

Before mounting it is recommended that the installation is planned out first.

- Be sure that the AC drive suits the mounting location.
- The mounting site must support the weight of the AC drive.
- Will the AC drive continuously withstand vibrations and/or shocks?
- Consider using a vibration damper.
- Check ambient conditions, ratings, required cooling air flow, compatibility of the motor, etc.
- Know how the AC drive will be lifted and transported.

---

**Note:** IP20 units are intended for cabinet mounting.

---

### 2.1 Lifting instructions

---

**Note:** To prevent personal risks and any damage to the unit during lifting, it is advised that the lifting methods described below are used.

---

Recommended for IP 54 AC drive models -090 to -365

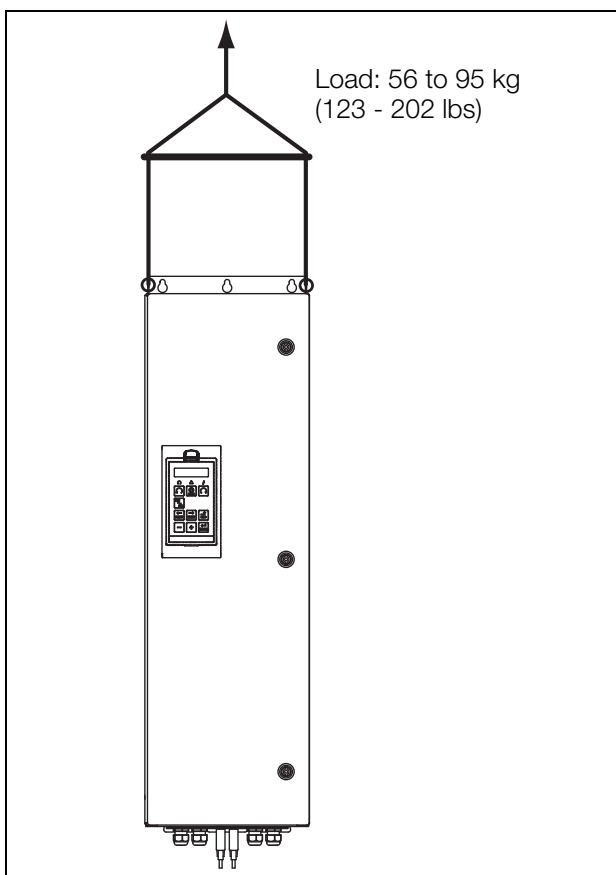
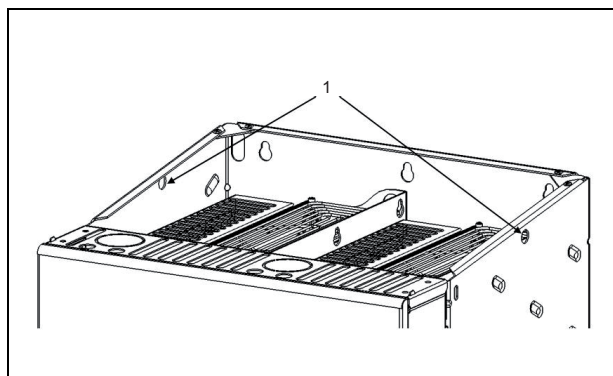

Fig. 2 Lifting IP 54 AC drive model -090 to -365.

Recommended lifting points for IP 20 modules size H/H69 and up



1	Hole diameter =17 mm (x2)
---	---------------------------

Fig. 3 Lifting holes.

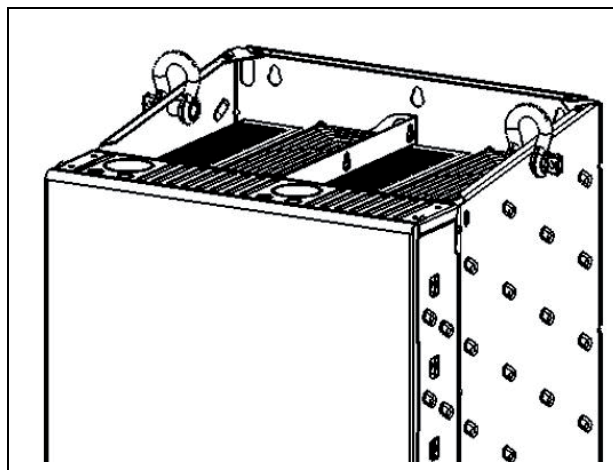

Fig. 4 Lifting holes with lifting shackles.

---

**Note:** Lifting shackles not included in the drive delivery.

---

## Recommended for AC drive cabinet models -430 to -3K0

**Note: To prevent personal risks and any damage to the unit during lifting, it is advised that the lifting methods described below are used.**

### Transport by crane

All enclosures are suitable for transporting by crane, either as free-standing enclosures or as bayed suites.

### With eyebolts

Individual enclosures are safely transported using the eyebolts.

For symmetrical loads, the following maximum permissible overall loads apply:

Cable/chain angle A	Permitted load (F)
45 °	4 800 N (1080 lbf)
60 °	6 400 N (1439 lbf)
90 °	13 600N (3057 lbf)

**Note: Calculated load F as  $F [N] = m [kg] \times 9.81$ .**

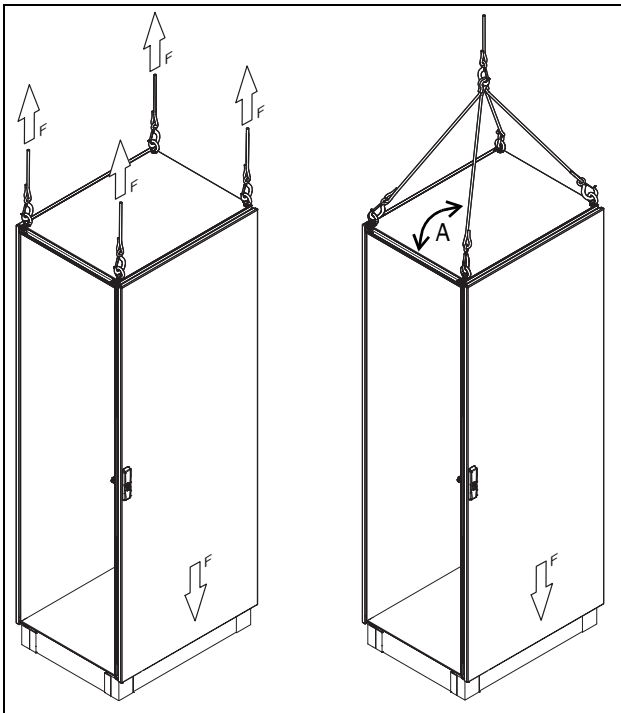

Fig. 5 Lifting enclosures with eyebolts.

### With combination angle

For the enclosure combination with internal baying brackets and combination angles shown here, the load capacity with a cable pull angle of 60° is as follows:

F1 = 7000 N

F2 = 7000 N

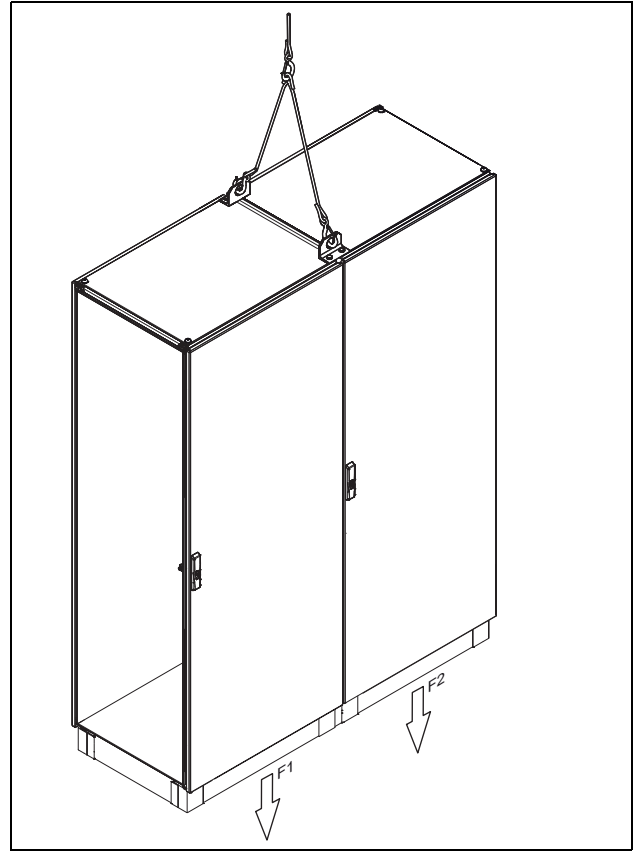

Fig. 6 Enclosure combination with internal brackets.

For the enclosure combination with internal baying brackets and combination angles shown here, the load capacity with a cable pull angle of 60° is as follows:

- F1 = 7000 N
- F2 = 14000 N
- F3 = 7000 N

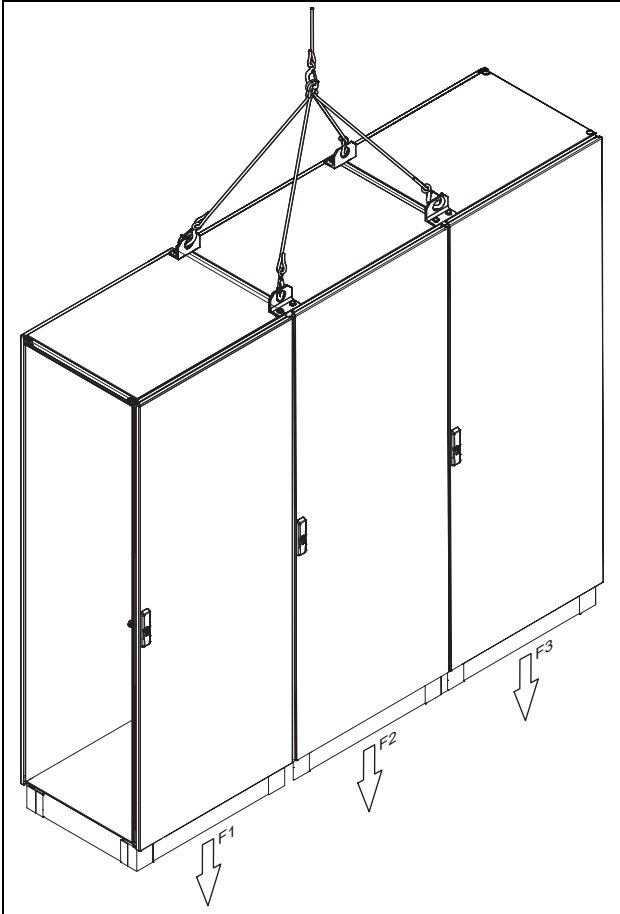

Fig. 7 Enclosure combination with internal brackets.

## Transport by fork-lift truck

When transporting individual and bayed enclosures, please take care to ensure that the base/plinth trim panels are fitted, and loads are restricted to the immediate vicinity of the base/plinth corner pieces.

### Transport of individual enclosures

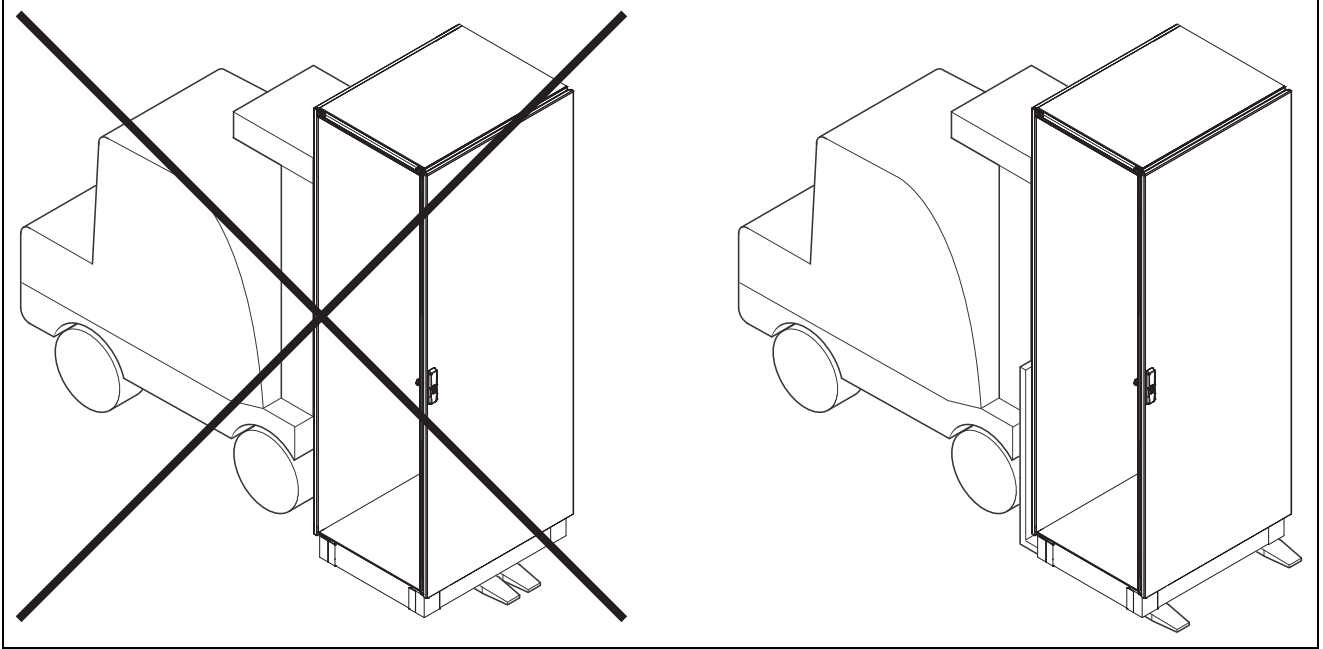

Fig. 8 Transport of individual enclosure with fork-lift truck.

### Transport of bayed enclosure suites

For the enclosure combination with internal baying brackets the following load capacities are supported:

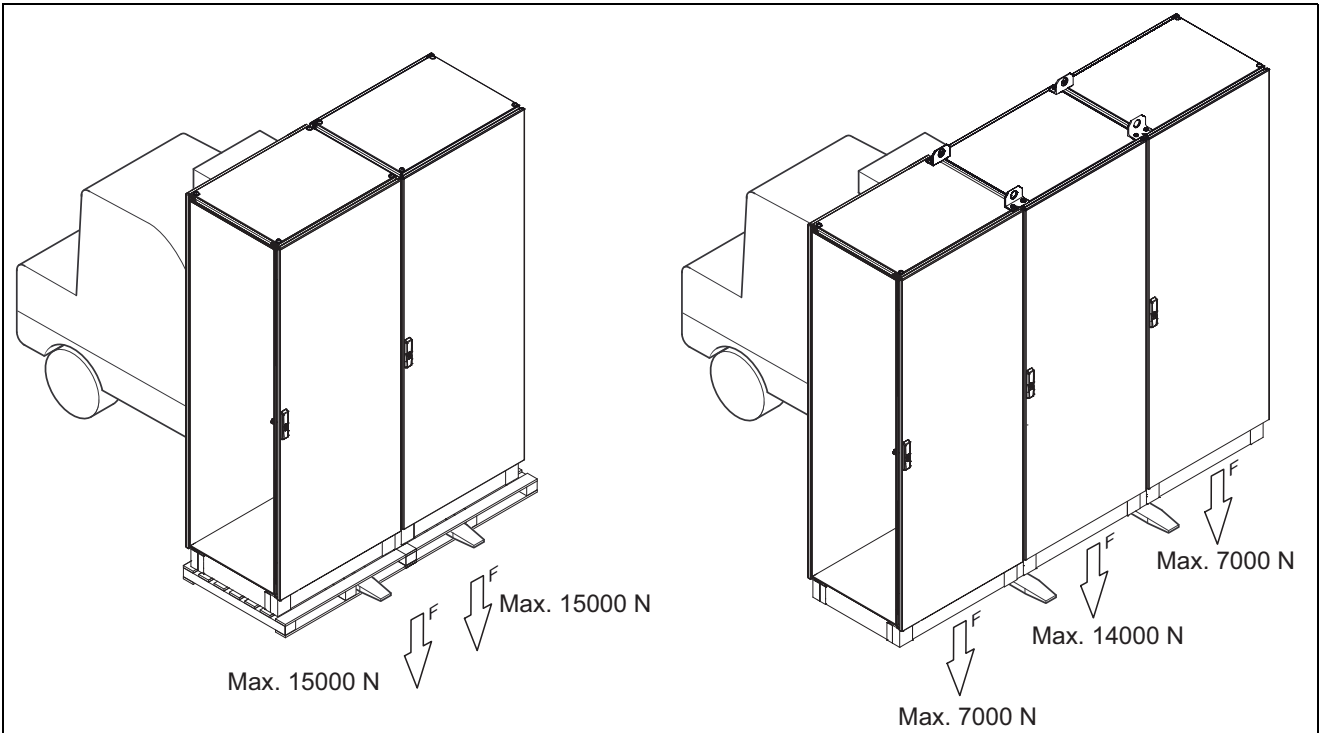

Fig. 9 Transport of enclosure combination with fork-lift truck.

## 2.2 Stand-alone units

The AC drive must be mounted in a vertical position against a flat surface. Use the template (in the File archive on our homepage) to mark out the position of the fixing holes.

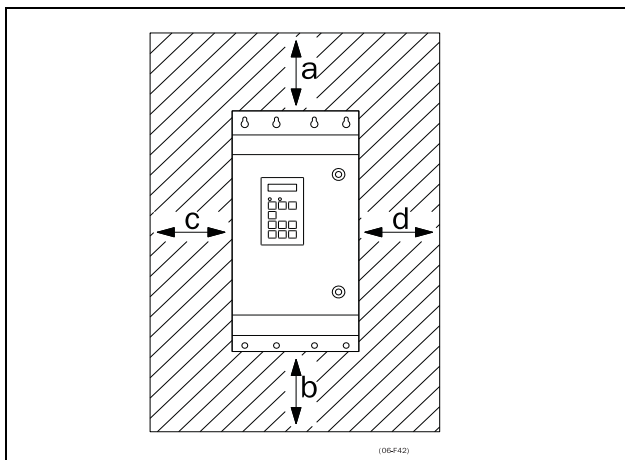

Fig. 10 AC drive mounting model 002 to 3K0

### 2.2.1 Cooling

Fig. 10 shows the minimum free space required around the AC drive for the models 002 to 3K0 in order to guarantee adequate cooling. Because the fans blow the air from the bottom to the top it is advisable not to position an air inlet immediately above an air outlet.

The following minimum separation between two AC drives, or a AC drive and a non-dissipating wall must be maintained. Valid if free space on opposite side.

Table 5 Mounting and cooling

		Frame size B - FA, C2-FA2, C69-F69, C2(69)-D2(69) [mm(in)]	Frame size C2, D2, E2, F2 with IP21 top cover option [mm(in)]	430-3K0 cabinet [mm(in)]
2xVFX, side- by-side mm (in)	a	200 (7.9)	200 (7.9)	100 (3.9)
	b	200 (7.9)	200 (7.9)	0
	c	0	50 (1.97)	0
	d	0	50 (1.97)	0
3 or more VFX units B/C/D/C2/ D2 side-by- side mm (in)	a	200 (7.9)	200 (7.9)	100 (3.9)
	b	200 (7.9)	200 (7.9)	0
	c	50 (1.97)	50 (1.97)	0
	d	50 (1.97)	50 (1.97)	0
3 or more VFX units E/F/E2/F2 side-by-side mm (in)	a	200 (7.9)	200 (7.9)	100 (3.9)
	b	200 (7.9)	200 (7.9)	0
	c	100 (3.9)	50 (1.97)	0
	d	100 (3.9)	50 (1.97)	0
VFX-wall, wall-one side mm (in)	a	100 (3.9)	100 (3.9)	100 (3.9)
	b	100 (3.9)	100 (3.9)	0
	c	0	50 (1.97)	0
	d	0	50 (1.97)	0

**NOTE:** When a 430 to 3K0 model is placed between two walls, a minimum distance at each side of 200 mm (7.9 in) must be maintained.

## 2.2.2 Mounting schemes

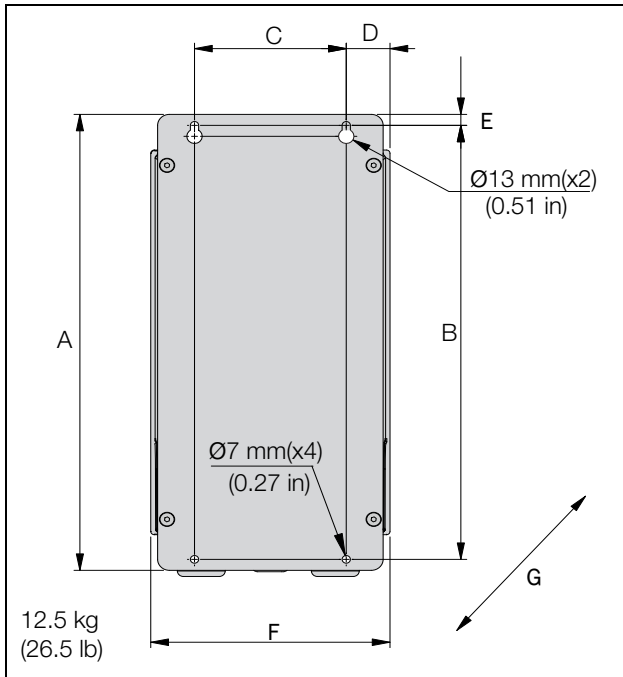

Fig. 11 Emotron VFX Model 48/52-003 to 018 (Frame size B).

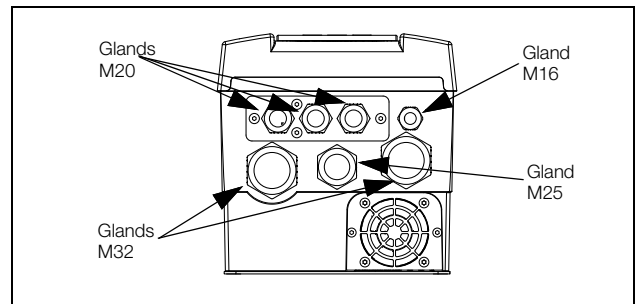

Fig. 12 Cable interface for mains, motor and communication, Emotron VFX Model 48/52-003 to 018 (Frame size B).

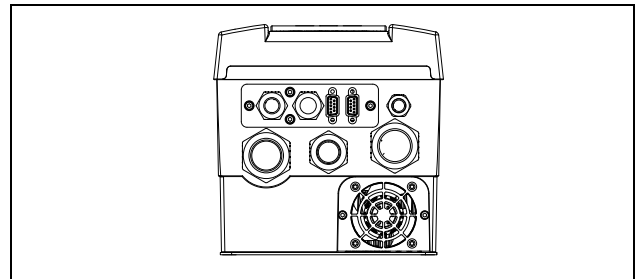

Fig. 13 Emotron VFX Model 48/52-003 to 018 (Frame size B) example with optional CRIO interface and D-sub connectors.

Table 6 Dimensions connected to Fig. 11.

Frame size	Emotron VFX model	Dimensions in mm (in)						
		A	B	C	D	E	F	G (depth)
B	003 - 018	416 (16.4)	396 (15.6)	128.5 (5.04)	37 (1.46)	10 (0.39)	202.6 (7.98)	203 (7.99)

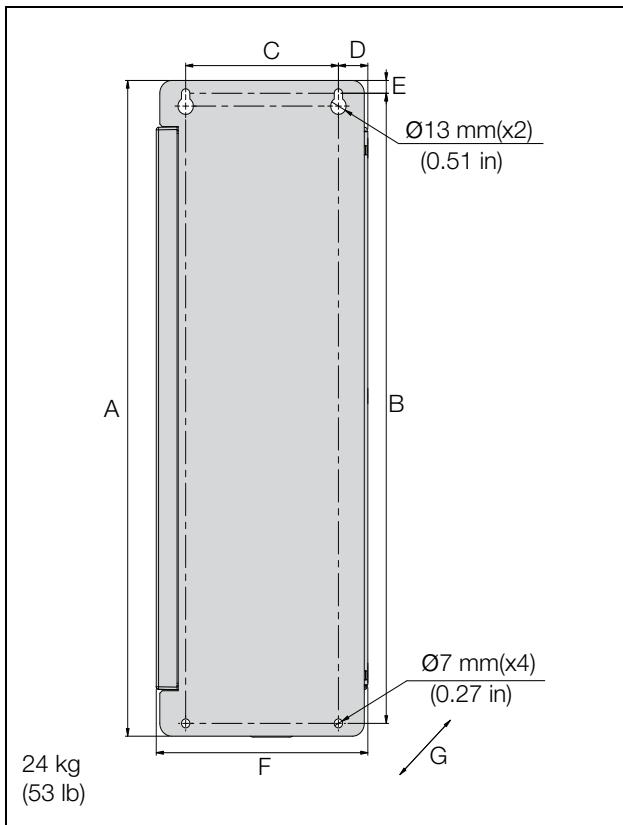

Fig. 14 Emotron VFX Model 48/52-026 to 046 (Frame size C).

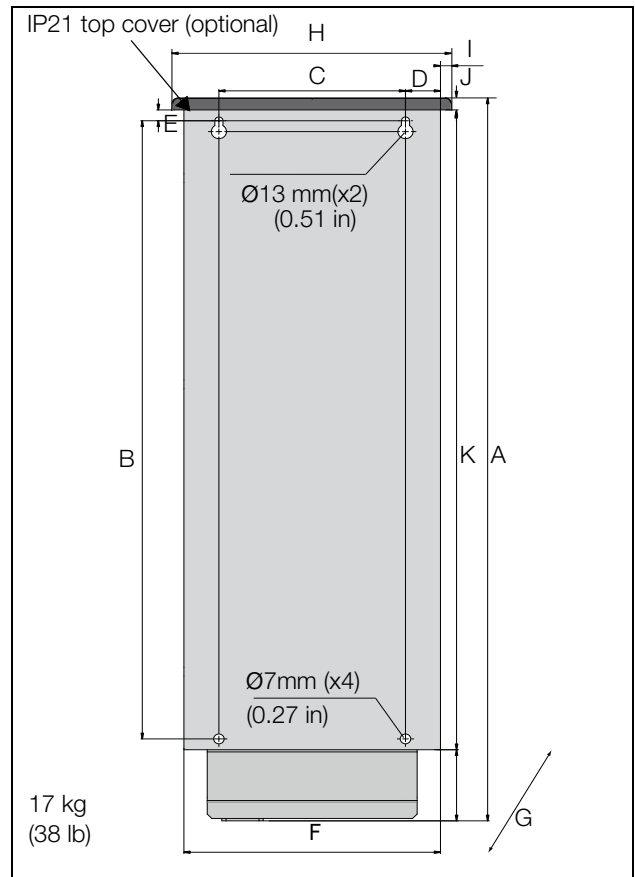

Fig. 16 Emotron VFX Model 48-025 to 48-058 (Frame size C2), Model 69-002 to 69-025 (Frame size C2(69)), backside view.

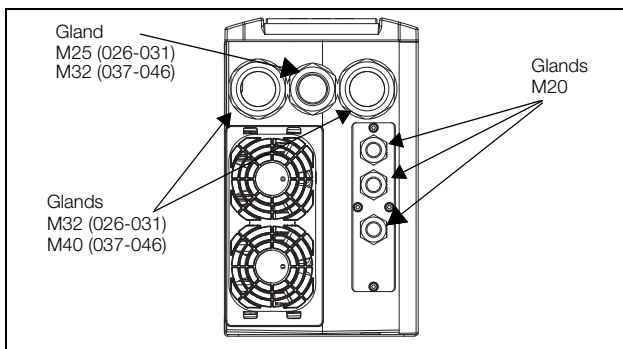

Fig. 15 Cable interface for mains, motor and communication, Emotron VFX Model 48/52-026 to 046 (Frame size C).

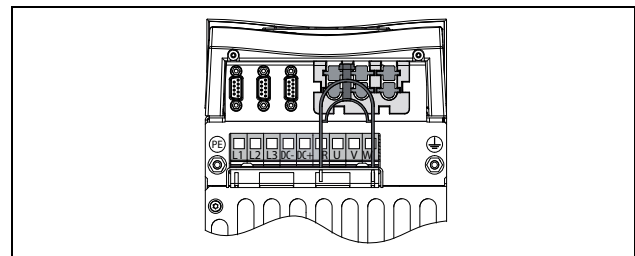

Fig. 17 Bottom view Emotron VFX Model 48-025 to 48-058 (Frame size C2) Model 69-002 to 69-025 (Frame size C2(69)), with cable interface for mains, motor, DC+/DC-, brake resistor and control.

Table 7 Dimensions connected to Fig. 14 and Fig. 16.

Frame size	Emotron VFX model	Dimensions in mm (in)										
		A	B	C	D	E	F	G (depth)	H	I	J	K
C	026 - 046	512 (20.2)	492 (19.4)	128.5 (5.04)	24.8 (0.95)	10 (0.39)	178 (7)	292 (11.5)	-	-	-	-
C2	025 - 058	585.5 (23)	471 (18.5)	128.5 (5.04)	23.8 (0.91)	13 (0.51)	167 (7)	267 (10.5)	196 (7.7)	10 (0.39)	23.5 (0.9)	496 (19.5)
C2(69)	002 - 025							IP21 282 (11.1)				

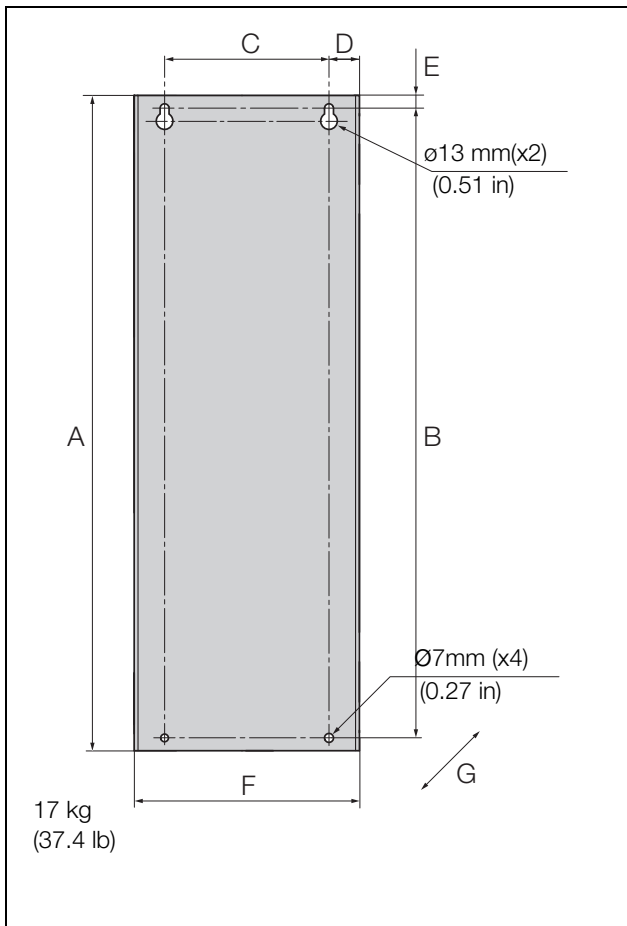

Fig. 18 Emotron VFX Model 69-002 to 025 (Frame size C69).

Table 8 Dimensions connected to Fig. 18.

Frame size	Emotron VFX model	Dimensions in mm (in)						
		A	B	C	D	E	F	G (depth)
C69	002-025	512 (20.2)	492 (19.4)	128.5 (5.06)	24.8 (0.98)	10 (0.39)	178 (7.01)	314 (12.36) Excl. PPU G 291.5 (11.5)

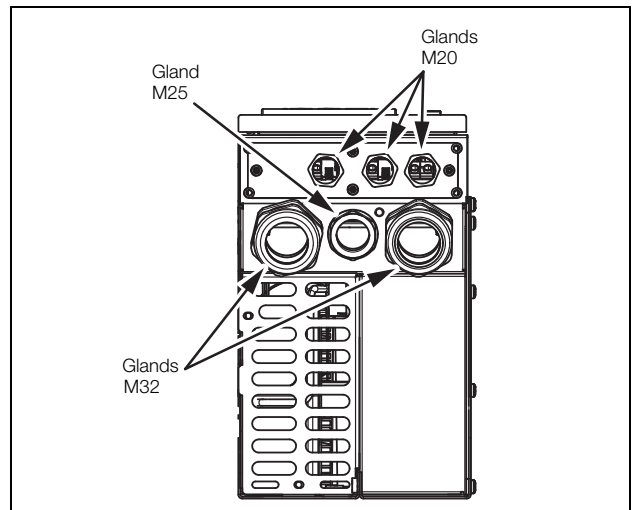

Fig. 19 Cable interface for mains, motor and communication, Emotron VFX Model 69-002 to 025 (Frame size C69).

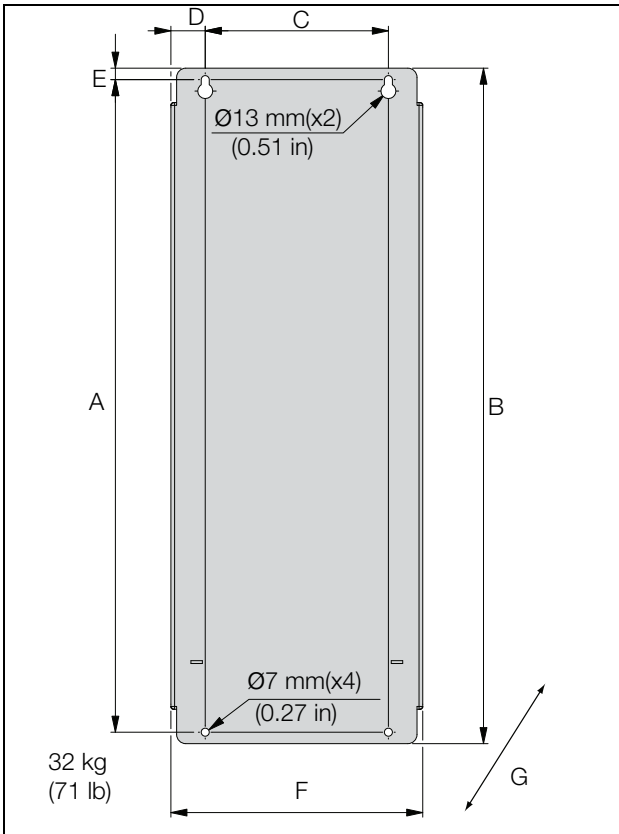

Fig. 20 Emotron VFX Model 48/52-061 to 074 (Frame size D), Model 69-033 to 69-058, (Frame size D69).

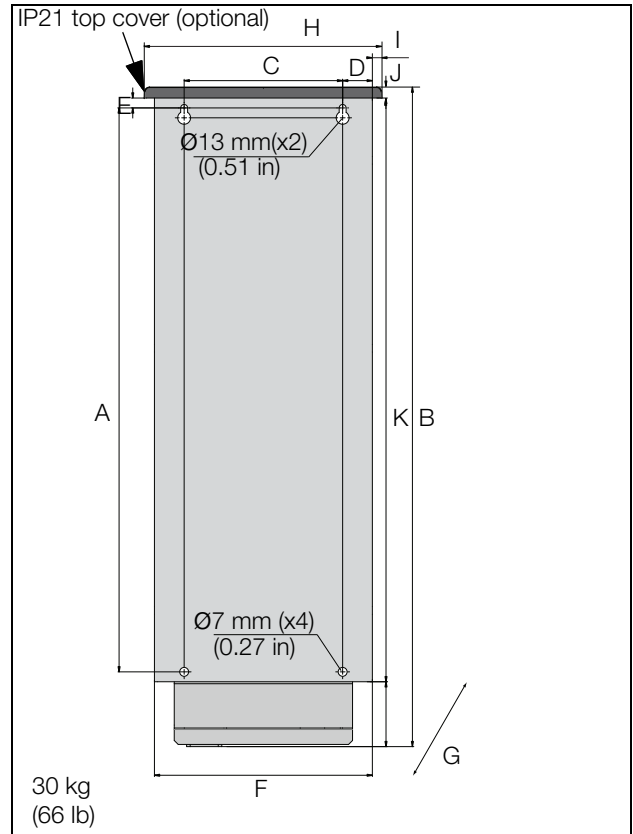

Fig. 22 Emotron VFX Model 48-060 to 48-105 (Frame size D2), Model 69-033 to 69-058 (Frame size D2(69)), backside view.

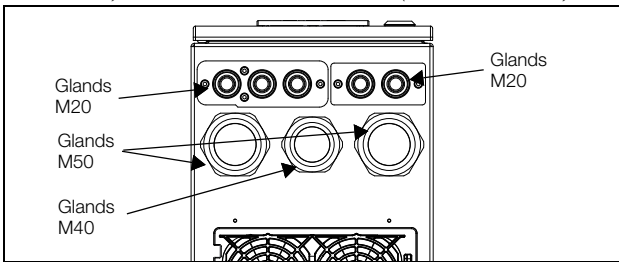

Fig. 21 Cable interface for mains, motor and communication, Emotron VFX Model 48/52-061 and 074 (Frame size D), Model 69-033 to 69-058 (Frame size D69).

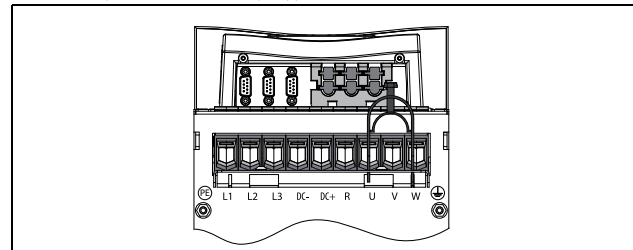

Fig. 23 Bottom view Emotron VFX Model 48-060 to 48-105 (Size D2), Model 69-033 to 69-058 (Frame size D2(69)), with cable interface for mains, motor, DC+/DC-, brake resistor and control.

**NOTE:** Glands for size B, C, D, C69 and D69 are available as option kit.

Table 9 Dimensions connected to Fig. 20 and Fig. 22.

Frame size	Emotron VFX model	Dimensions in mm (in)										
		A	B	C	D	E	F	G (depth)	H	I	J	K
D	061 - 074	570	590	160	30	10	220	295	-	-	-	-
D69	033 - 058	(22.4)	(23.2)	(6.3)	(0.9)	(0.39)	(8.7)	(11.6)				
D2	060 - 105	570	669.5	160	30	13	220	291 (11.5)	240	10	12.5	590
D2(69)	033 - 058	(22.4)	(26.3)	(6.3)	(0.9)	(0.51)	(8.7)	IP21 - 307 (12.1)	(9.5)	(0.39)	(0.47)	(23.2)

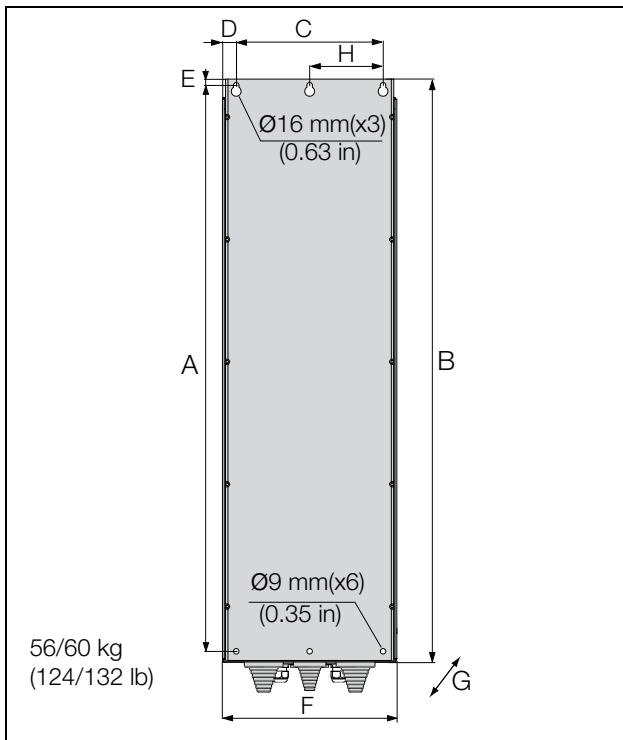

Fig. 24 Emotron VFX Model 48-090 to 175 (Frame size E).

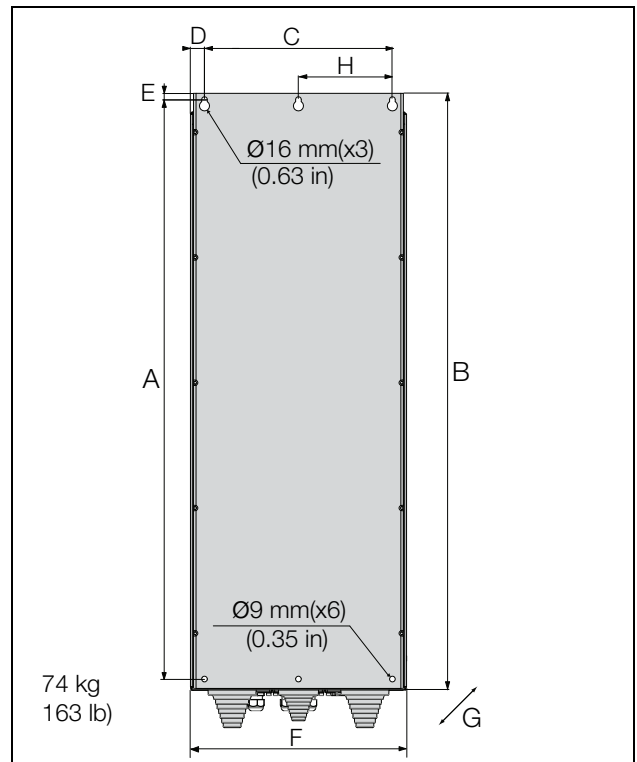

Fig. 26 Emotron VFX Model 48-210 to 295 (Frame size F), Emotron VFX Model 69-82 to 200 (Frame size F69).

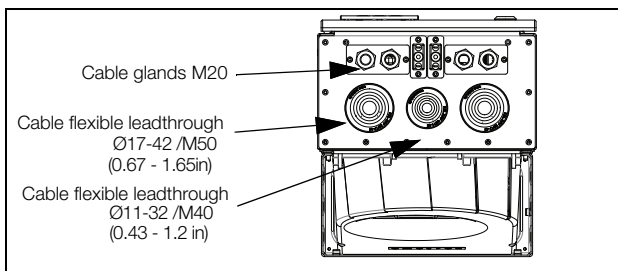

Fig. 25 Cable interface for mains, motor, DC+/DC-, brake resistor and communication, Emotron VFX Model 48-090 to 175 (Frame size E).

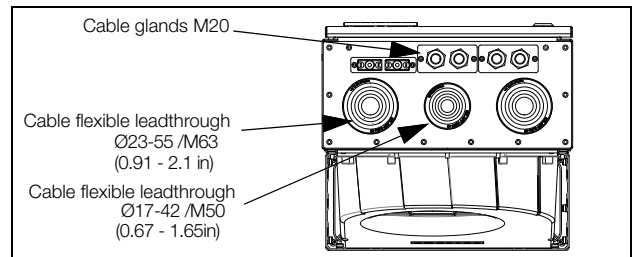

Fig. 27 Cable interface for mains, motor, DC+/DC-, brake resistor and communication, Emotron VFX Model 48-210 to 295 (Frame size F), Emotron VFX Model 69-082 to 200 (Frame size F69).

Table 10 Dimensions IP54 connected to Fig. 24 and Fig. 26.

Frame size	Emotron VFX model	Dimension in mm (in)							
		A	B	C	D	E	F	G (depth)	H
E	090 - 175	925 (36.4)	950 (37.4)	240 (9.5)	22.5 (0.88)	10 (0.39)	284.5 (11.2)	314 (12.4)	120 (4.7)
F	210 - 295	925 (36.4)	950 (37.4)	300 (11.8)	22.5 (0.88)	10 (0.39)	344.5 (13.6)	314 (12.4)	150 (5.9)
F69	082 - 200	1065 (41.9)	1090 (42.9)						

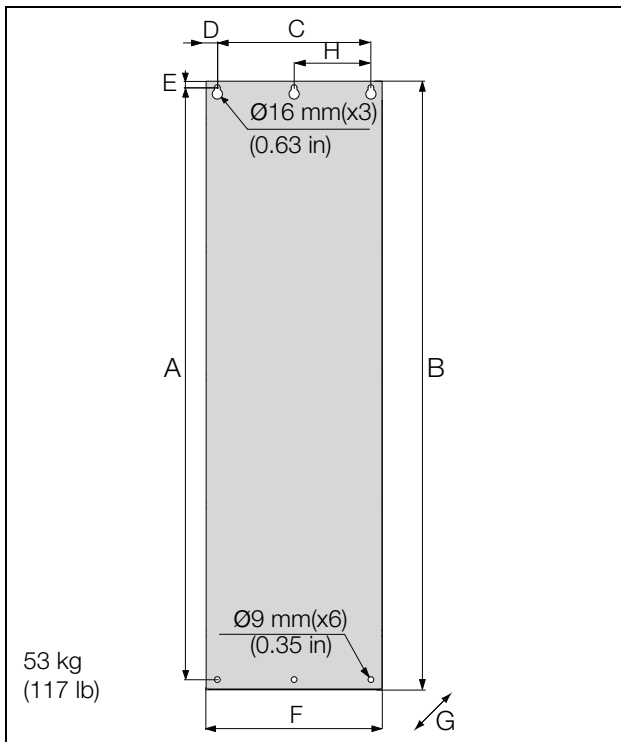

Fig. 28 Emotron VFX/ Model 48-142 to 48-171 (Frame size E2).

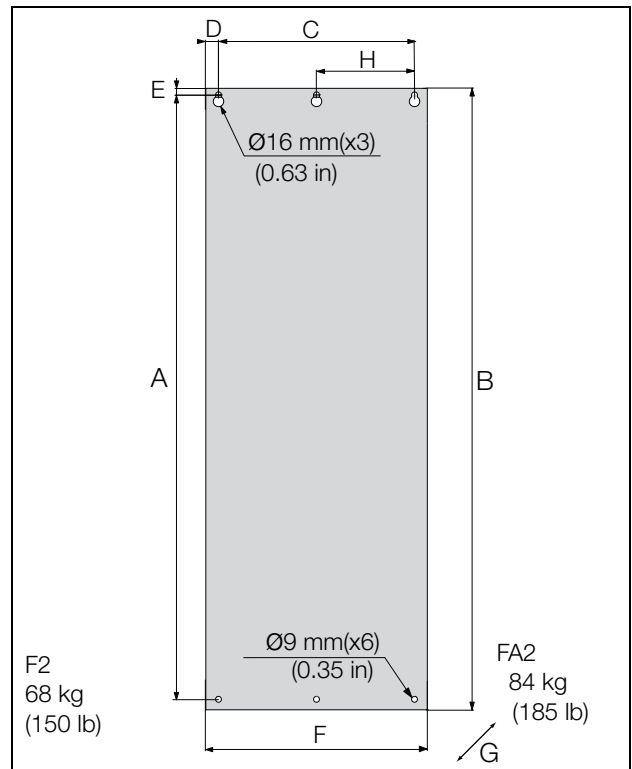

Fig. 30 Emotron VFX/ Model 48-205 to 48-293 (Frame size F2) and 48-365-20 (Frame size FA2).

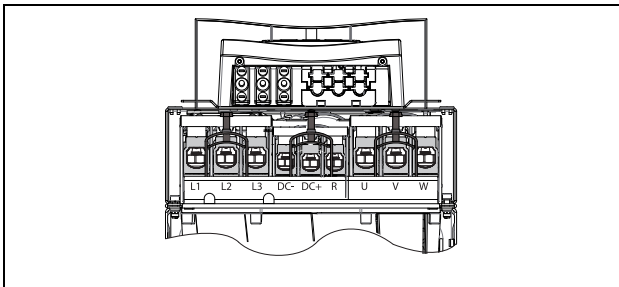

Fig. 29 Bottom view Emotron VFX/ Model 48-142 to 48-293 (Frame size E2 and F2), with cable interface for mains, motor, DC+/DC-, brake resistor and control. (principle drawing).

Table 11 Dimensions IP20 connected to Fig. 28 and Fig. 30.

Frame size	Emotron VFX model	Dimension in mm (in)							
		A	B	C	D	E	F	G (depth)	H
E2	142 - 171	925 (36.4)	950 (37.4)	240 (9.5)	17.5 (0.68)	10 (0.39)	275 (10.8)	294 (11.6) IP21 - 323 (12.7)	120 (4.7)
F2	205 - 293			300 (11.8)				335 (13.2)	294 (11.6) IP21 - 323 (12.7)
FA2	365	1065 (41.9)	1090 (42.9)					306 (12.1) IP21 - 323 (12.7)	

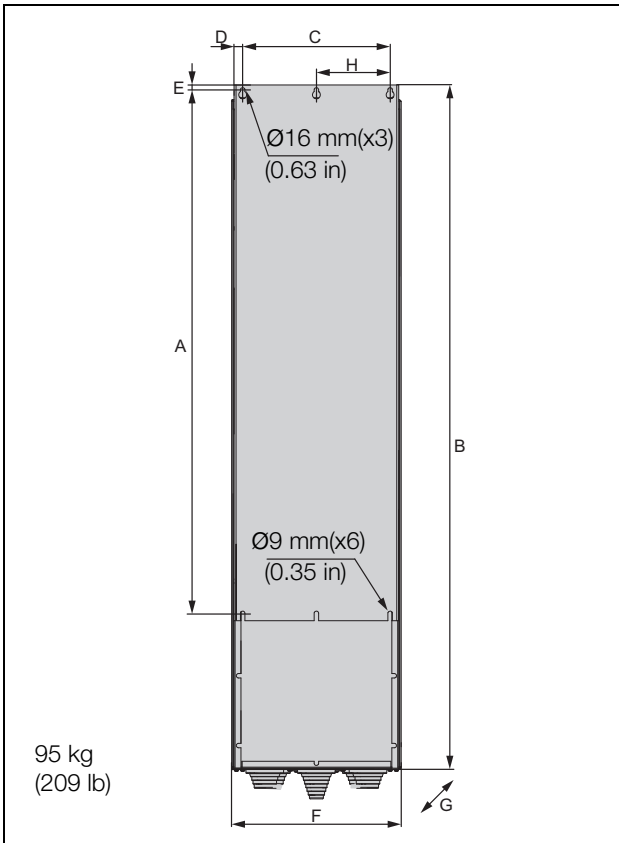

Fig. 31 Emotron VFX Model 48-365-54 (Frame size FA).

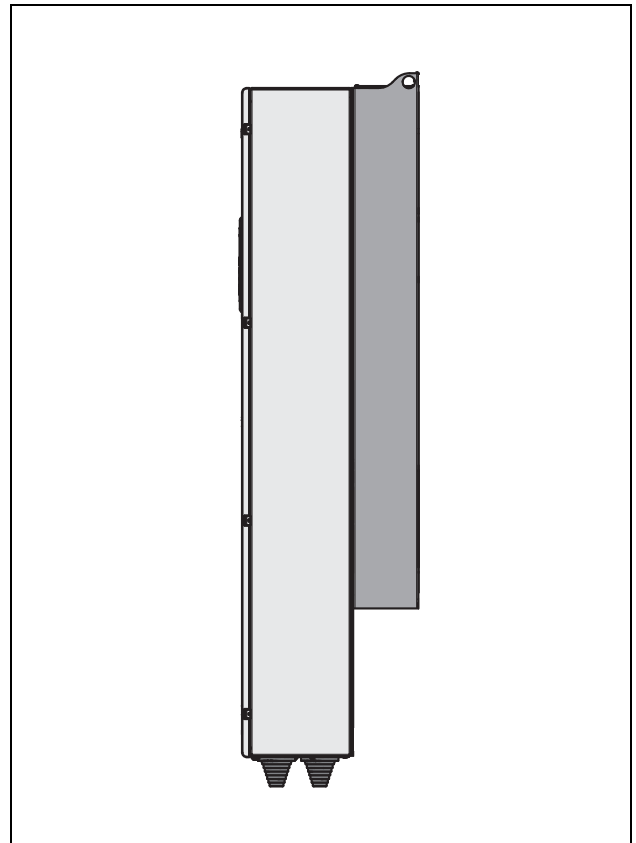

Fig. 33 Side view Emotron VFX Model 48-365-54 (Frame size FA).

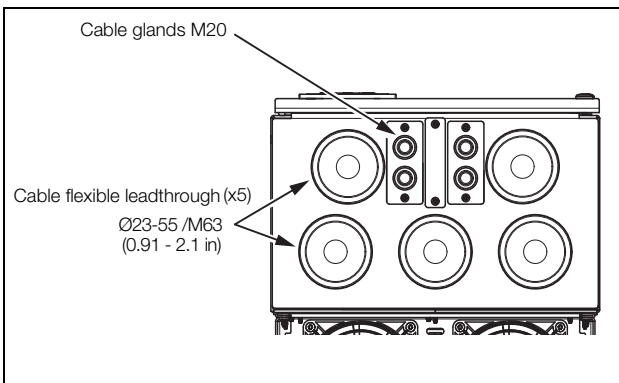

Fig. 32 Cable interface for mains, motor, DC+/DC-, brake resistor and communication, Emotron VFX Model 48-365-54 (Frame size FA).

Table 12 Dimensions IP54 connected to Fig. 31.

Frame size	Emotron VFX model	Dimension in mm (in)							
		A	B	C	D	E	F	G (depth)	H
FA	365	1065 (41.9)	1395 (54.9)	300 (11.8)	17.5 (0.68)	10 (0.39)	345 (13.6)	365 (14.4)	150 (5.9)

## 2.3 Cabinet mounting

### 2.3.1 Cooling

If the variable speed drive is installed in a cabinet, the rate of airflow supplied by the cooling fans must be taken into consideration.

Frame	Emotron VFX Model	Flow rate m <sup>3</sup> /h (ft <sup>3</sup> /min)
B	003 - 018	75 (44)
C - C2	025 - 031	120 (71)
C - C2	036 - 058	170 (100)
C69	002 - 025	170 (100)
C2(69)	002 - 025	170 (100)
D - D2	060 - 105	170 (100)
D69	033 - 058	170 (100)
D2(69)	033 - 058	170 (100)
E - E2	090 - 175	510 (300)
F - F2	205 - 295	800 (471)
FA - FA2	365	1020 (600)
F69	090 - 200	800 (471)
G2	590	2500 (1471)
G3	810-885	3250 (1913)
H	430 - 500	1600 (942)
H2	660-730	2700 (1589)
H3	1010-1100	4050 (2384)
H4	1300-1460	5400 (3178)
H5	1710-1820	6750 (3973)
H6	2190	8100 (4767)
H69	250 - 400	1600 (942)
H7	2550	9450 (5562)
H8	2920	10800 (6357)
I69	430 - 595	2400 (1413)
J69	650 - 800	3200 (1883)
KA69	905 - 995	4000 (2354)
K69	1K2	4800 (2825)
L69	1K4	5600 (3296)
M69	1K6	6400 (3767)
N69	1K8	7200 (4238)
O69	2K0	8000 (4709)
P69	2K2	8800 (5179)
Q69	2K4	9600 (5650)
R69	2K6	10400 (6121)
S69	2K8	11200 (6592)
T69	3K0	12000 (7063)

**NOTE:** For the models 48-1300/69-650 to 69-3K0 the mentioned amount of air flow should be divided equally over the cabinets.

### 2.3.2 Recommended free space in front of cabinet

All cabinet mounted AC drives are designed in modules, so called PEBBs. These PEBBs can be folded out to be replaced. To be able to remove a PEBB in the future, we recommend at least 1.30 meter (39.4 in) free space in front of the cabinet, see Fig. 34.

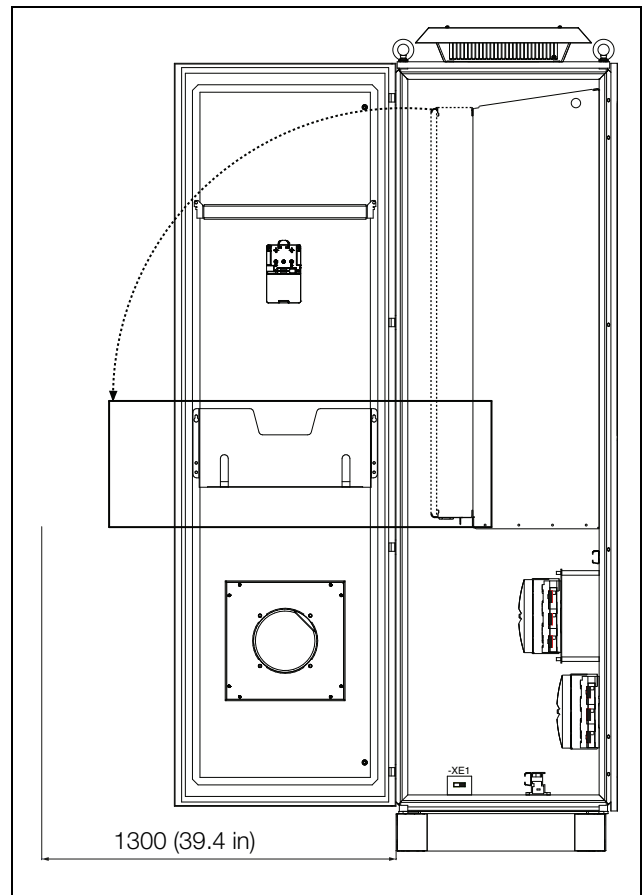
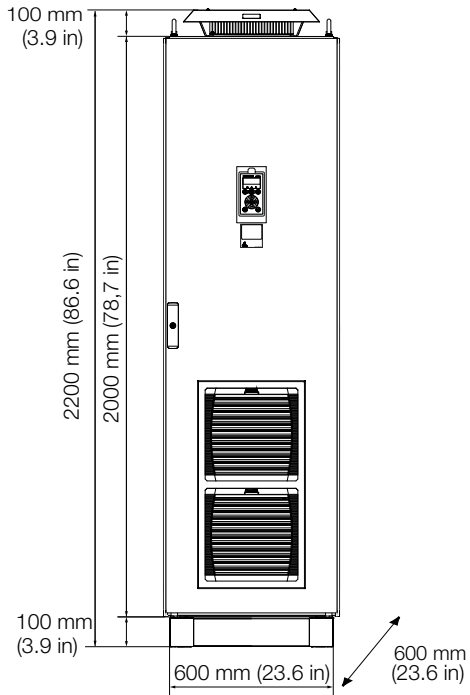
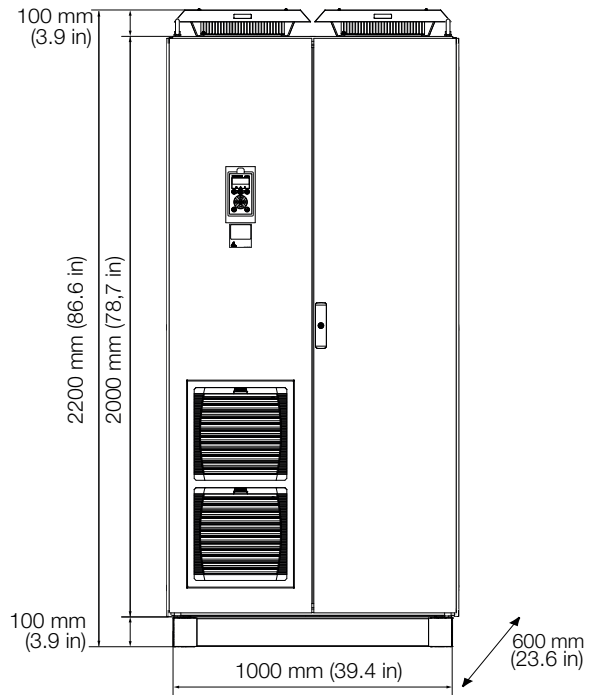

Fig. 34 Recommended free space in front of the cabinet mounted AC drive.

### 2.3.3 Mounting schemes, cabinets



Emotron VFX48: Model 430 to 730 (Frame sizes H, G2 and H2)  
Emotron VFX69: Model 250 to 400 (Frame size H69)



Emotron VFX48: Model 810 to 1100 (Frame sizes G3 and H3)  
Emotron VFX69: Model 430 to 595 (Frame size I69)

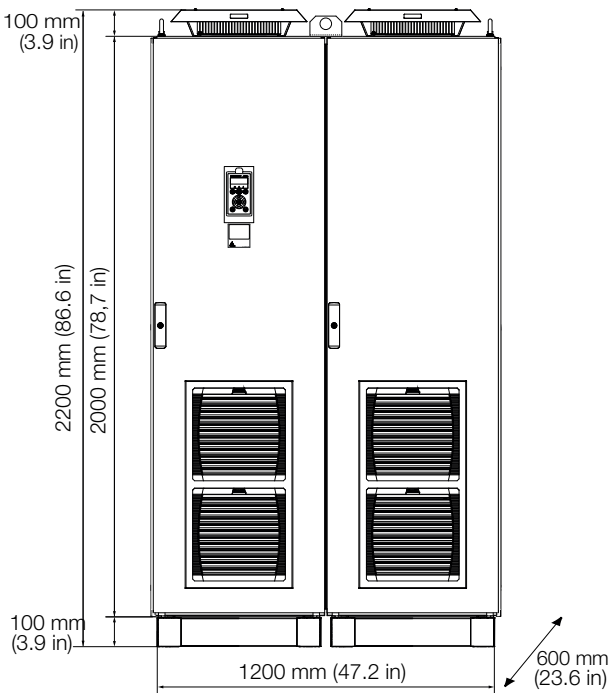

Emotron VFX48: Model 1300 to 1460 (Frame size H4)  
Emotron VFX69: Model 650 to 800 (Frame size J69)

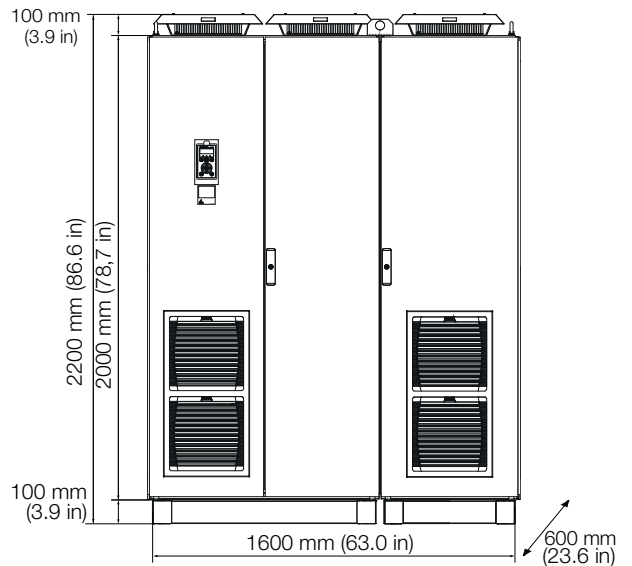

Emotron VFX48: Model 1710 to 1820 (Frame size H5)  
Emotron VFX69: Model 905 to 995 (Frame size KA69)

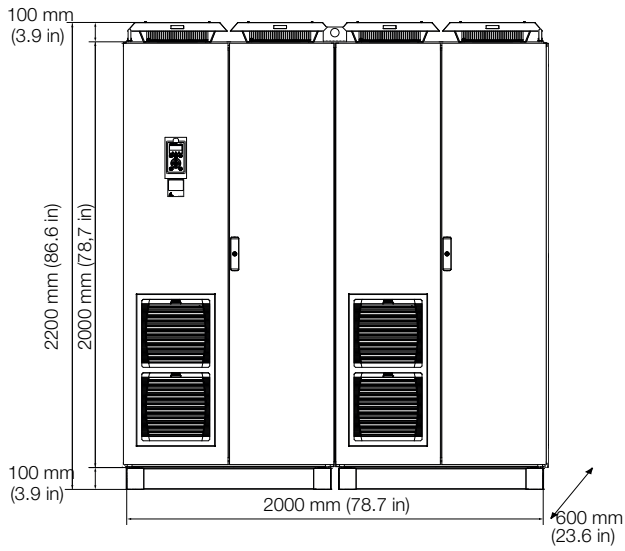

Emotron VFX48: Model 2190 (Frame size H6)  
 Emotron VFX69: Model 1K2 (Frame size K69)

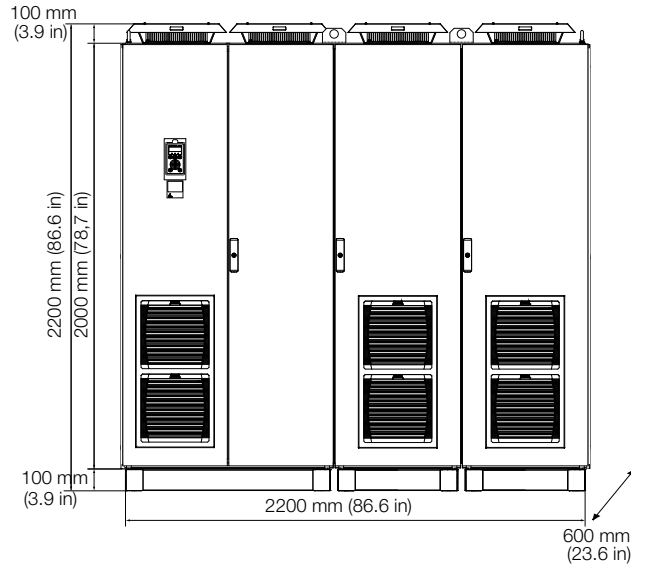

Emotron VFX48: Model 2550 (Frame size H7)  
 Emotron VFX69: Model 1K4 (Frame size L69)

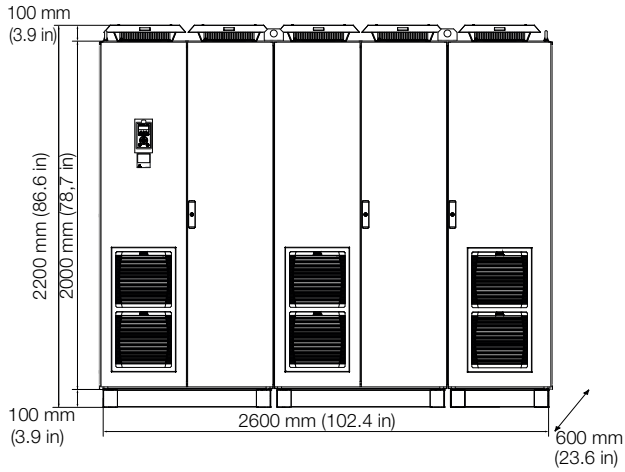

Emotron VFX48: Model 2920 (Frame size H8)  
 Emotron VFX69: Model 1K6 (Frame size M69)



## 3. Installation

The description of installation in this chapter complies with the EMC standards and the Machine Directive.

Select cable type and screening according to the EMC requirements valid for the environment where the AC drive is installed.

### 3.1 Before installation

Read the following checklist and prepare for your application before installation.

- Local or remote control.
- Long motor cables (>100m (> 330 ft)), refer to Section Long motor cables page 35.
- Motors in parallel, refer to menu Section , page 101.
- Functions used.
- Suitable AC drive size in proportion to the motor/application.

If the AC drive is temporarily stored before being connected, please check the technical data for environmental conditions. If the AC drive is moved from a cold storage room to the room where it is to be installed, condensation can form on it. Allow the AC drive to become fully acclimatised and wait until any visible condensation has evaporated before connecting the mains voltage.

### 3.1.1 Remove/open front cover

#### Frame sizes B - FA (IP54)

Remove/open the front cover to access the cable connections and terminals. On Frame size B and C loosen the four screws and remove the cover. On Frame size D and up unlock the hinged cover with the key and open it. On Frame size FA loosen the three screws on the hinged cover and open it.

#### Frame size C2 - F2 and FA2 (IP20/21)

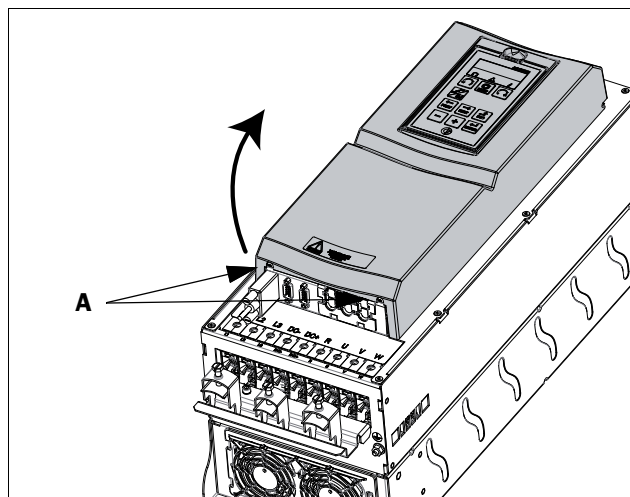

Fig. 35 Remove the front cover on frame size C2 - F2 and FA2 (principle drawing).

To be able to access all cable connections and terminals, first open and remove the front cover in following order.

- Loosen the two screws A (see Fig. 35) at the bottom of the cover a couple of turns (you do not have to remove the screws).
- Swing out the lower part of the cover a bit and remove the cover downwards. Be careful, don't swing out the cover too much as this could damage the "lips" at the upper hinges.  
Now it is easy to access all terminals.

### 3.1.2 Remove/open the lower front cover on Frame size E2, F2 and FA2 (IP20/21)

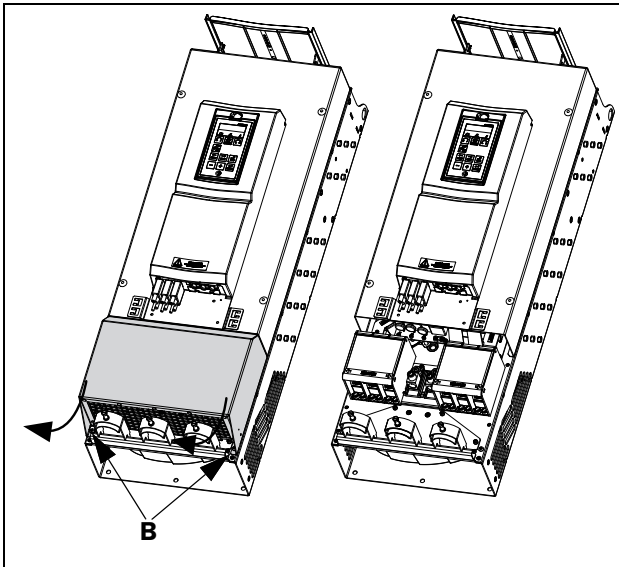

Fig. 36 Loosen the two screws and remove the lower cover (principle drawing).

In order to access the mains, motor, DC+/DC- and brake terminals, remove the lower cover in following order

- Loosen the two screws B (see Fig. 36).
- Pull down the cover a bit and lift it away.

## 3.2 Cable connections for small and medium frame sizes

IP54 - VFX48/52-003 to 074 (Frame sizes B, C and D)

IP54-VFX69-002 to 058 (Frame sizes C69 and D69)

IP20/21 - VFX48-025 to 365 (Frame sizes C2, D2, E2, F2 and FA2)

IP20/21 - VFX69-002 to 058 (Frame sizes C2(69) and D2(69))

### 3.2.1 Mains cables

Dimension the mains and motor cables according to local regulations. The cable must be able to carry the AC drive load current.

#### Recommendations for selecting mains cables

- To fulfil EMC purposes it is not necessary to use screened mains cables on the supply side.
- Use heat-resistant cables, +75 °C (167 °F) or higher.
- Dimension the cables and fuses in accordance with local regulations and the nominal input current of the drive See Table 65, page 244.
- PE conductor cross-sectional area on supply side shall for phase cable size < 16 mm<sup>2</sup> (6 AWG) be >10 mm<sup>2</sup> Cu (16 mm<sup>2</sup> Al) or use a second PE conductor with same area as original PE conductor. For cable size above 16mm<sup>2</sup> (6 AWG) but smaller or equal to 35mm<sup>2</sup> (2 AWG) the PE conductor cross-sectional area shall be at least 16mm<sup>2</sup> (6 AWG). For cables >35mm<sup>2</sup> (>2 AWG) the PE conductor cross-sectional area should be at least 50% of the used phase conductor cross-sectional. When the PE conductor in the used cable type is not in accordance with the above mentioned cross-sectional area requirements, a separate PE conductor should be used to establish this.
- The litz ground connection see Fig. 48, is only necessary if the mounting plate is painted. All the AC drives have an unpainted back side and are therefore suitable for mounting on an unpainted mounting plate.

Connect the mains cables according to Fig. 37 to 45. The AC drive has as standard a built-in RFI mains filter that complies with category C3 which suits the Second Environment standard.

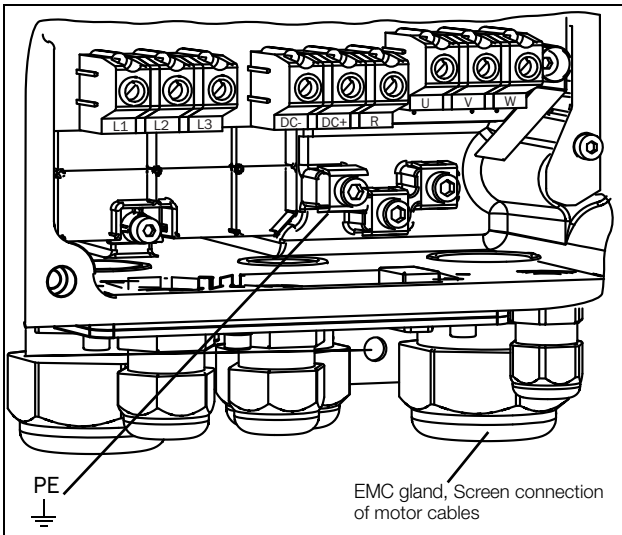

Fig. 37 Mains and motor connections, model 003-018, frame size B.

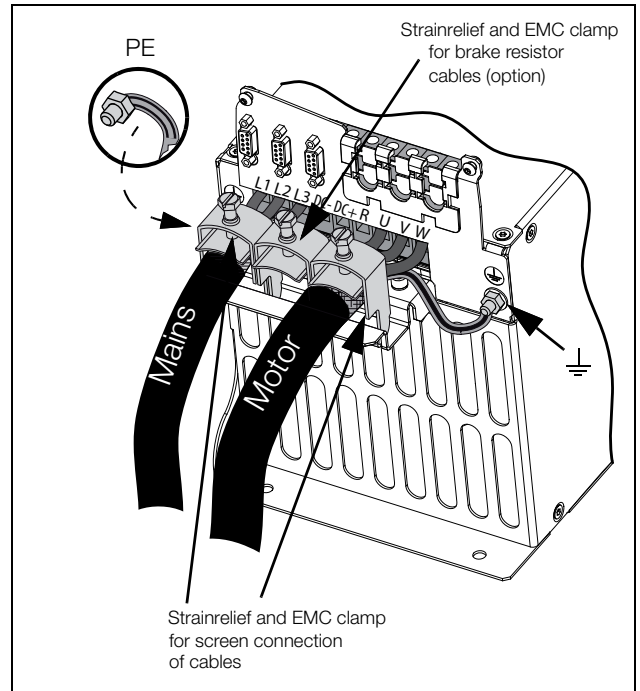

Fig. 40 Mains and motor connections model 48-025 to 48-058, frame size C2 and model 69-002 to 69-025 frame size C2(69).

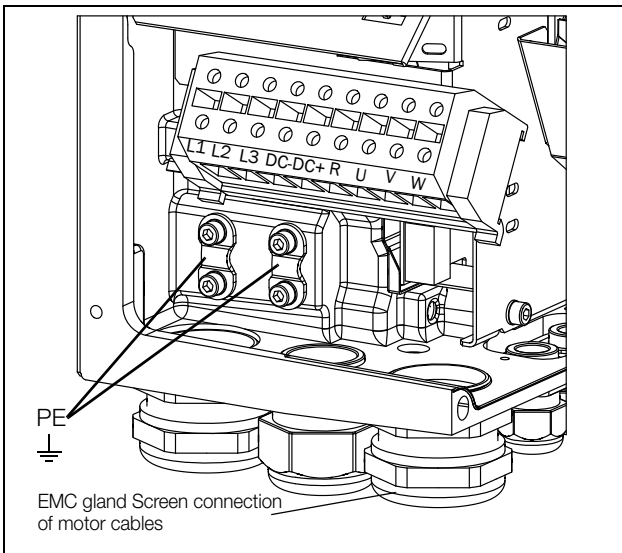

Fig. 38 Mains and motor connections, model 026-046, frame size C.

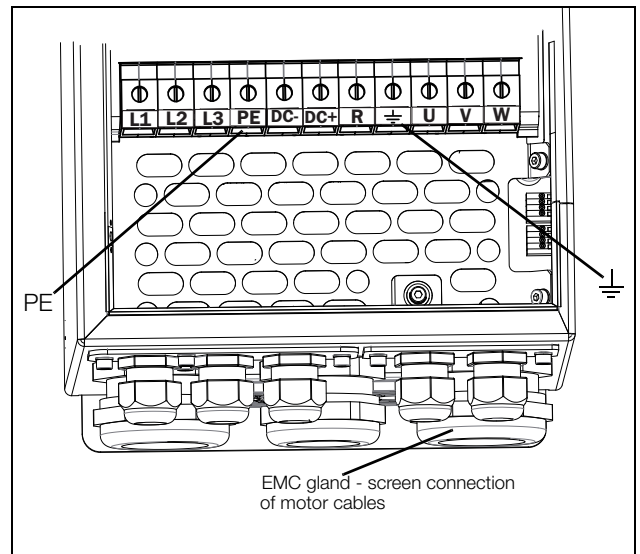

Fig. 41 Mains and motor connection, model 061 - 074, frame size D and model 69-033 to 69-058 frame size D69.

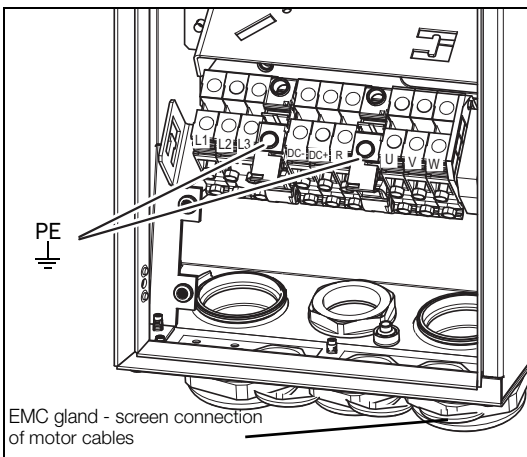

Fig. 39 Mains and motor connections, model 002-025, frame size C69.

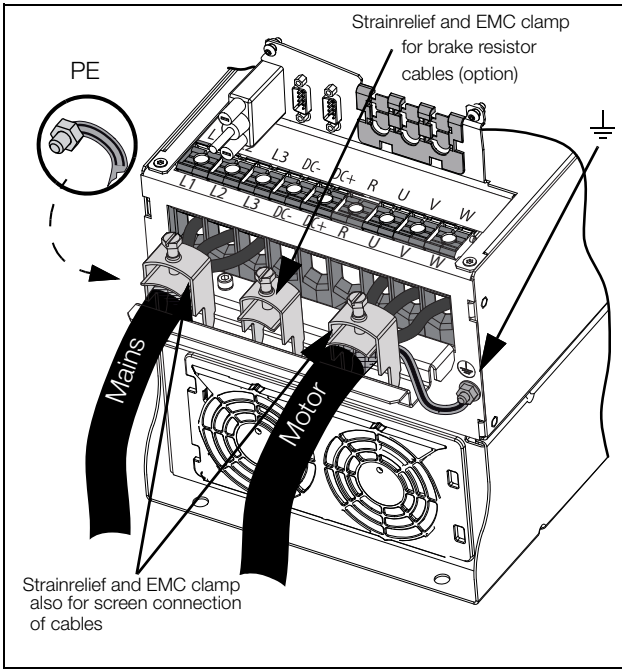

Fig. 42 Mains and motor connections model 48-060 to 48-105, frame size D2 and model 69-033 to 69-058 frame size D2(69).

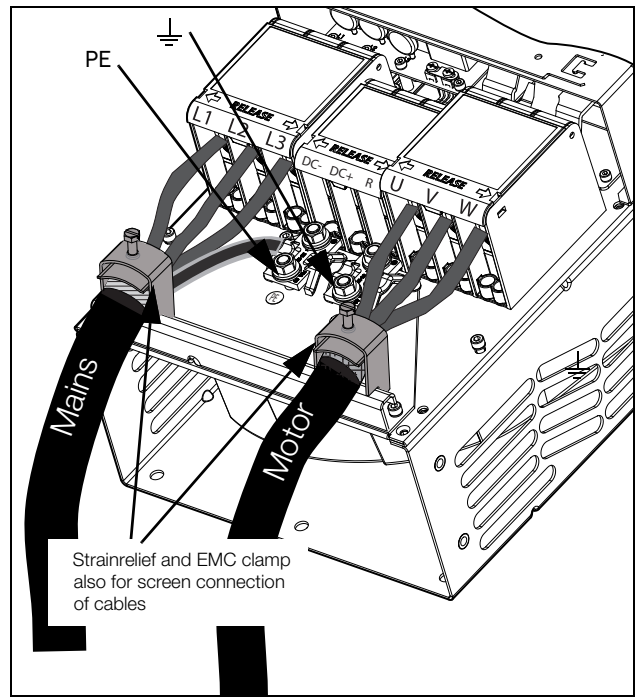

Fig. 44 Mains and motor connections model 48-142 to 48-293 (frame sizes E2 and F2) with the optional terminals for DC-, DC+ and Brake (principle drawing).

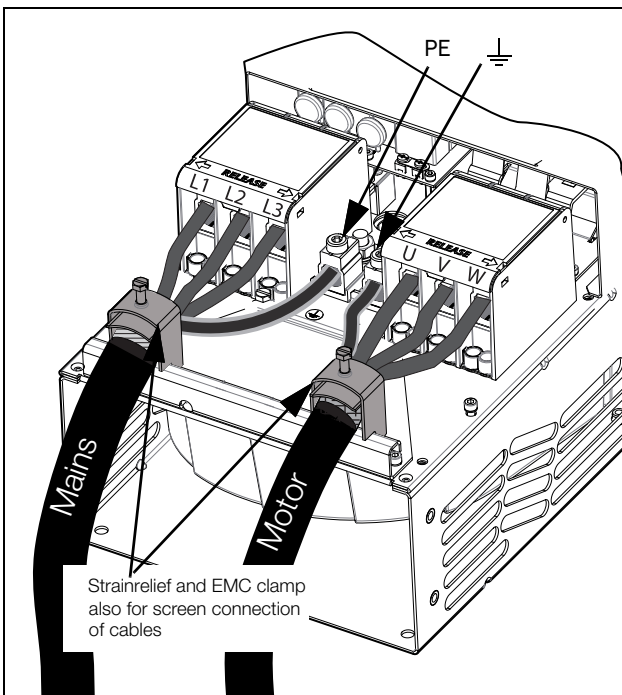

Fig. 43 Mains and motor connections model 48-142 to 48-293 (frame sizes E2 and F2) (principle drawing).

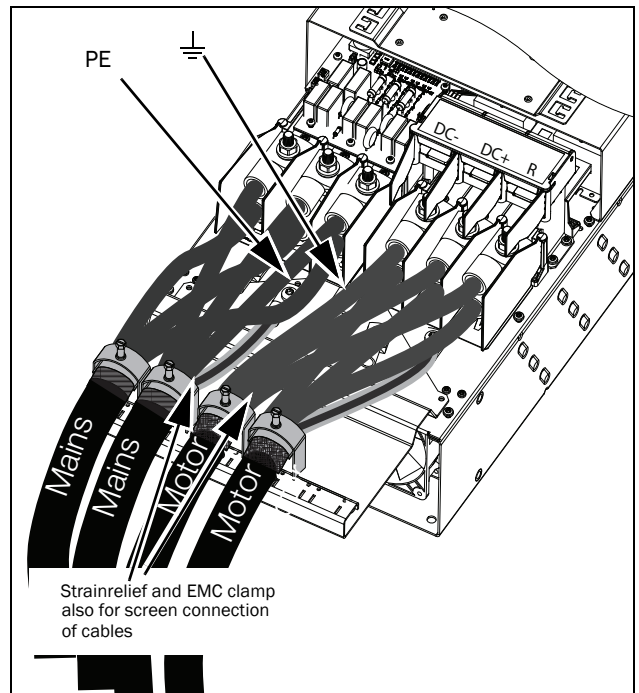



Fig. 45 Mains and motor connections model 48-365-20 (frame size FA2) with the optional terminals for DC-, DC+ and Brake (principle drawing).

Table 13 Mains and motor connections

L1,L2,L3 PE	Mains supply, 3 -phase Safety earth (protected earth)
 U, V, W	Motor earth Motor output, 3-phase
DC-,DC+,R	Brake resistor, DC-link connections (optional)

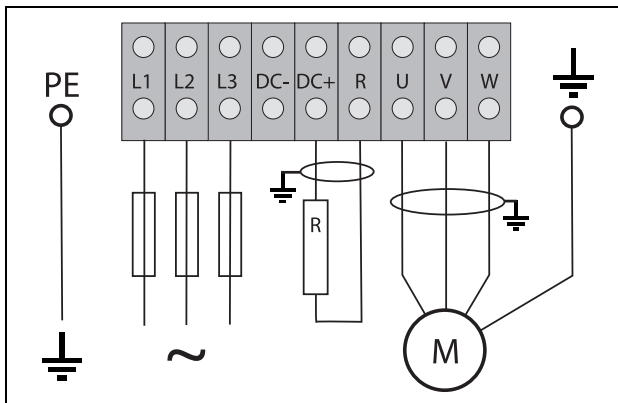



Fig. 46 Wiring example showing Protective earth, Motor earth and Brake Resistor connection.

**NOTE:** The Brake and DC-link Terminals are only fitted if the DC+/DC- option or Brake Chopper Option is built-in.



**WARNING!**  
The Brake Resistor must be connected between terminals DC+ and R.



**WARNING!**  
In order to work safely, the mains earth must be connected to PE and the motor earth to .

### 3.2.2 Motor cables

To comply with the EMC emission standards the AC drive is provided with a RFI mains filter. The motor cables must also be screened and connected on both sides. In this way a so-called “Faraday cage” is created around the AC drive, motor cables and motor. The RFI currents are now fed back to their source (the IGBTs) so the system stays within the emission levels.

#### Recommendations for selecting motor cables

- Use screened cables according to specification in Table 14. Use symmetrical shielded cable; three phase conductors and a concentric or otherwise symmetrically constructed PE conductor, and a shield.
- Use heat-resistant cables, +75 °C (167 °F) or higher.
- Dimension the cables in accordance with the rated current of the motor.
- Keep the motor cable between AC drive and motor as short as possible.
- The screening must be connected with a large contact surface of preferable 360° and always at both ends, to the motor housing and the AC drive housing. When painted mounting plates are used, scrape away the paint to obtain as large blank contact surface as possible at all mounting points for items such as saddles and the bare cable screening. Relying just on the connection made by the screw thread is not sufficient.

**NOTE:** It is important that the motor housing has the same earth potential as the other parts of the machine.

- The litz ground connection, see Fig. 48, is only necessary if the mounting plate is painted. All the AC drives have an unpainted back side and are therefore suitable for mounting on an unpainted mounting plate.

Connect the motor cables according to U - U, V - V and W - W, see Fig. 37, to Fig. 45.

**NOTE:** The terminals DC-, DC+ and R are options.

## Switches between the motor and the AC drive

If the motor cables are to be interrupted by maintenance switches, output coils, etc., it is necessary that the screening is continued by using metal housing, metal mounting plates, etc. as shown in the Fig. 48.

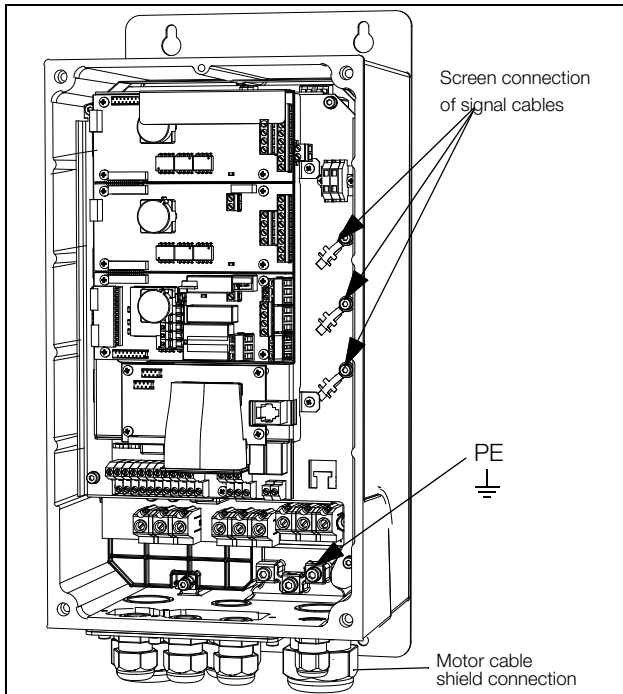

Fig. 47 Screen connection of cables.

Pay special attention to the following points:

- If paint must be removed, steps must be taken to prevent subsequent corrosion. Repaint after making connections!
- The fastening of the whole AC drive housing must be electrically connected with the mounting plate over an area which is as large as possible. For this purpose the removal of paint is necessary. An alternative method is to connect the AC drive housing to the mounting plate with as short a length of litz wire as possible.
- Try to avoid interruptions in the screening wherever possible.
- If the AC drive is mounted in a standard cabinet, the internal wiring must comply with the EMC standard. Fig. 48 shows an example of a AC drive built into a cabinet.

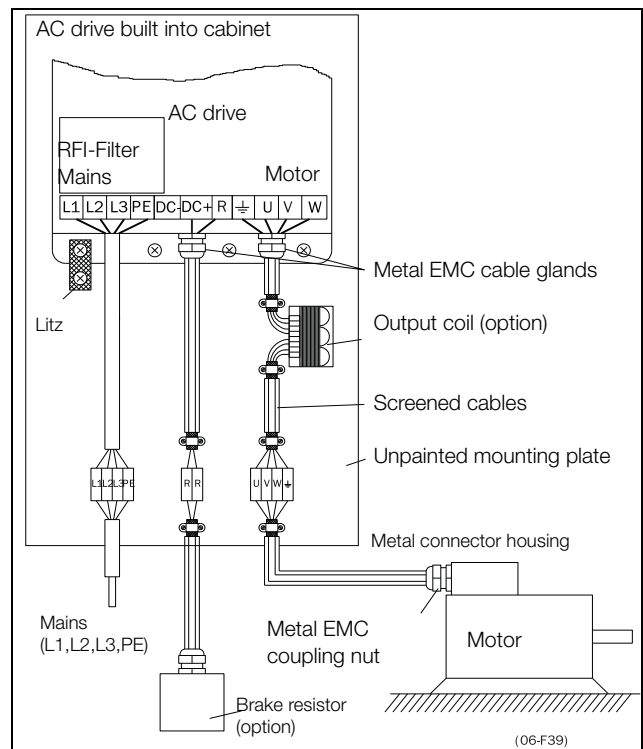

Fig. 48 AC drive in a cabinet on a mounting plate.

Fig. 49 shows an example when there is no metal mounting plate used (e.g. if IP54 AC drives are used). It is important to keep the “circuit” closed, by using metal housing and cable glands.

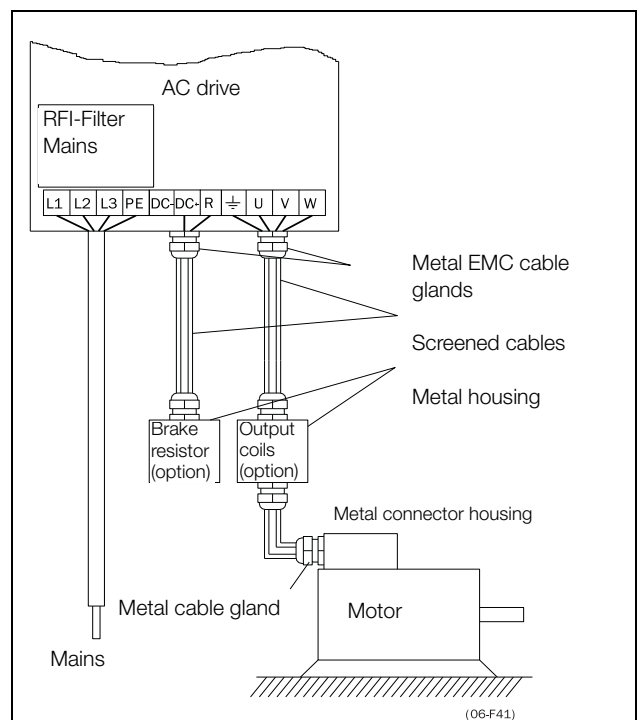

Fig. 49 AC drive as stand alone.

## Connect motor cables

1. Remove the cable interface plate from the AC drive housing.
2. Put the cables through the glands.
3. Strip the cable according to Table 15.
4. Connect the stripped cables to the respective motor terminal.
5. Put the cable interface plate in place and secure with the fixing screws.
6. Tighten the EMC gland with good electrical contact to the motor and brake chopper cable screens.

## Placing of motor cables

- Separate the power cables (AC drive, soft starter, output coils, filters, magnetic switches, etc.) from the signal cables (relay control circuit, PLC, sensors, control PCBs, electronics, etc.).
- Keep the control cables as far from the power cables as possible.
- If power cables and control cables must be laid close to each other, try to ensure that they do not run parallel, at least for a distance of no more than 300 mm (12 in). If necessary, use a cable tray with a division or stack the cable trays.
- Ensure that where power cables and control cables cross, they do so at 90° to each other.

## Long motor cables

If the connection to the motor is longer than 100 m (330 ft) (for powers below 7.5 kW (10.2 hp)) please contact CG Drives & Automation), it is possible that capacitive current peaks will cause tripping at overcurrent. Using output coils can prevent this. Contact the supplier for appropriate coils.

## Switching in motor cables

Switching in the motor connections is not advisable. In the event that it cannot be avoided (e.g. emergency or maintenance switches) only switch if the current is zero. If this is not done, the AC drive can trip as a result of current peaks.

## 3.3 Connection of motor and mains cables for larger frame sizes

IP54 - VFX 48-090 to 295 (Frame sizes E - F) and VFX 48-365-54 (Frame size FA) and VFX 69-082 to 200 (Frame size F69)

IP20 - VFX 48-430 and up (Frame sizes H and up) and VFX 69-250 and up (Frame sizes H69 and up).

### Emotron VFX48-090 to 48-295

### Emotron VFX69-082 to 69-200

To simplify the connection of thick motor and mains cables to the AC drive, the cable interface plate can be removed.

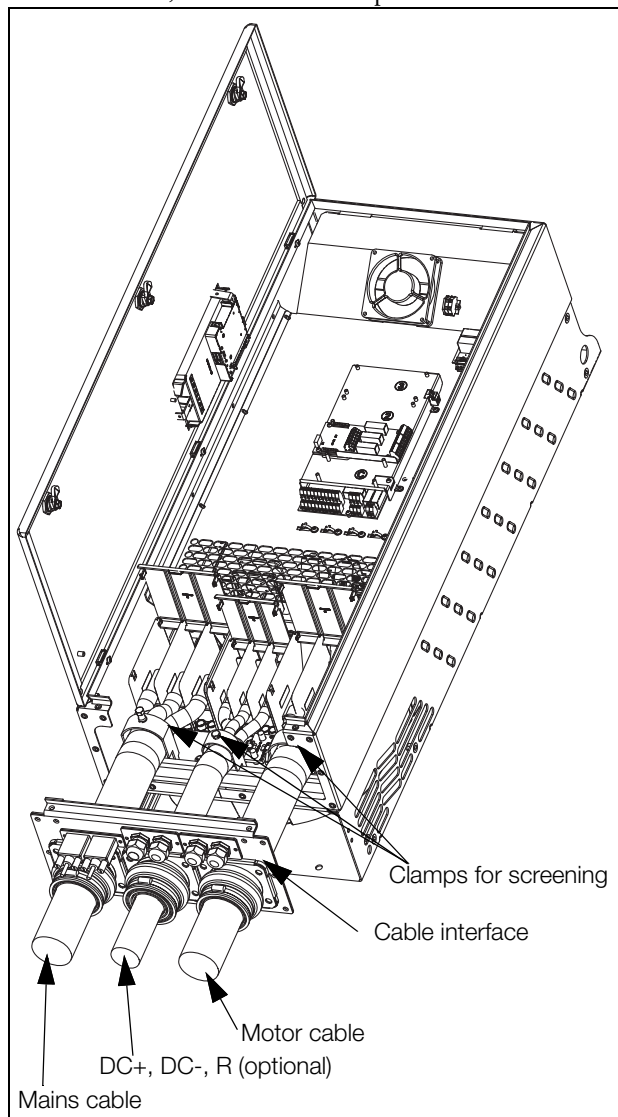

Fig. 50 Connecting motor and mains cables.

1. Remove the cable interface plate from the AC drive housing.
2. Put the cables through the glands.
3. Strip the cable according to Table 15.
4. Connect the stripped cables to the respective mains/motor terminal.
5. Fix the clamps on appropriate place and tighten the cable in the clamp with good electrical contact to the cable screen.
6. Put the cable interface plate in place and secure with the fixing screws.

## Emotron VFX48-365-54

To simplify the connection of thick motor and mains cables to the AC drive, the cable interface plate can be removed.

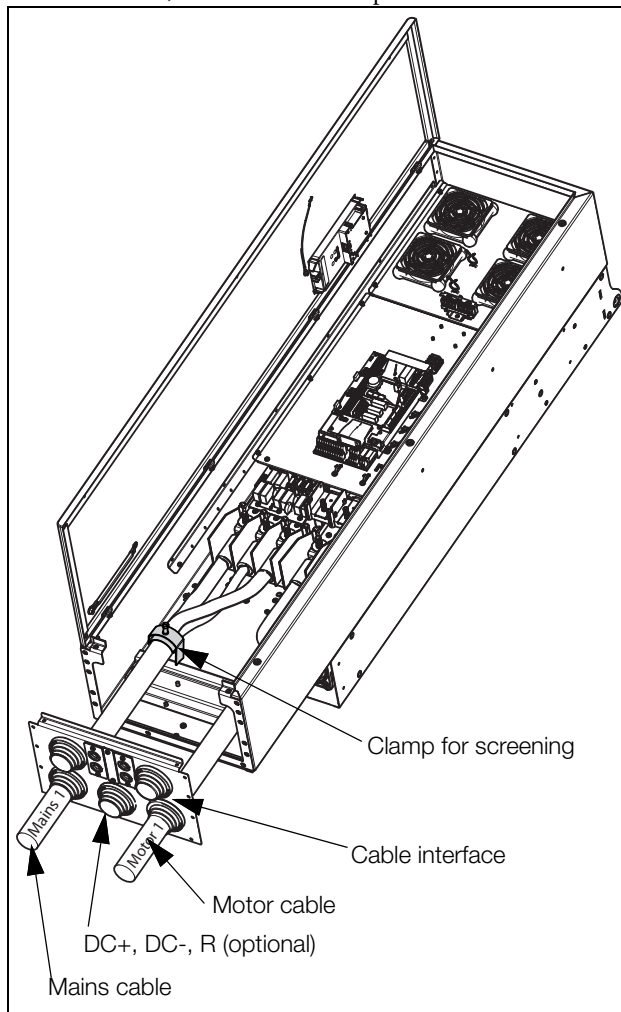

Fig. 51 Connection of lower mains and motor cables.

Start with the lower mains and motor cables (marked Mains 1 and Motor 1 in Fig. 52).

1. Remove the cable interface plate from the AC Drive housing.
2. Remove the upper mounting rail by loosen the four fastening screws.

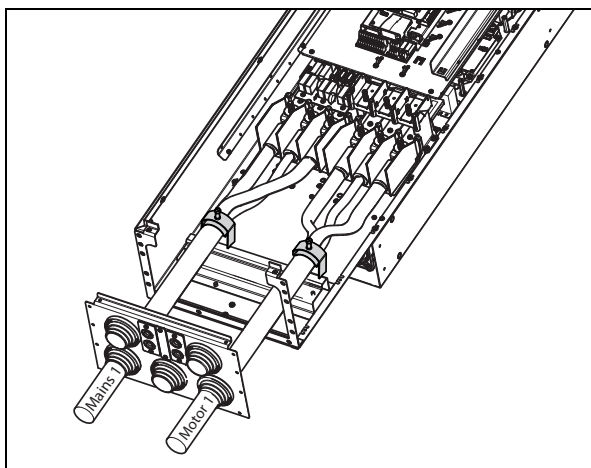

Fig. 52 Removed upper mounting rail.

3. Put the two lower cables (Mains 1 and Motor 1 cables) through the lower glands in the cable interface plate.
4. Strip the cables according to Table 15 and Fig. 61.
5. Connect the cable lugs to the stripped cable ends.
6. Connect the cable lugs to respective mains and motor terminal bolts.
7. Fix the clamps on appropriate place and tighten the cable in the clamp with good electrical contact to the cable screen.

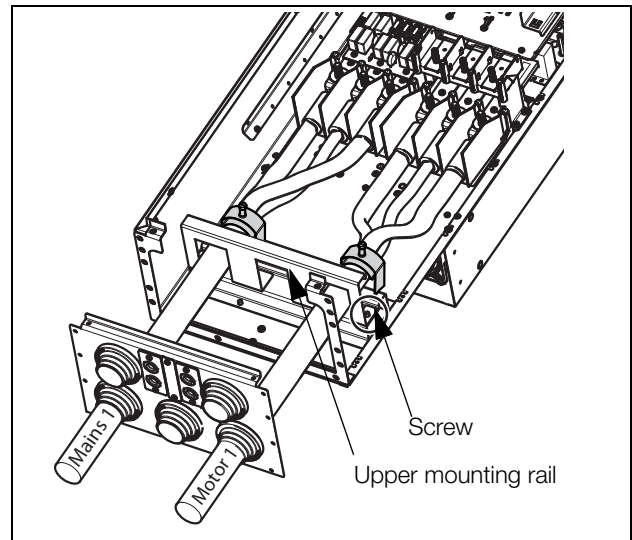

Fig. 53 Upper mounting rail mounted over the lower cables.

Continue with the upper mains and motor cables (marked Mains 2 and Motor 2 in Fig. 54).

1. Mount the upper mounting rail over the lower, connected cables (Mains 1 and Motor 1) at same place as before, with the four screws.
2. Put the two upper cables (Mains 2 and Motor 2) through the glands in the cable interface plate.
3. Strip the cables according to Table 17 and Fig. 61.
4. Connect the cable lugs to the stripped cable ends.
5. Connect the cable lugs to respective mains/motor terminal bolts.
6. Fix the clamps on appropriate place and tighten the cable in the clamp with good electrical contact to the cable screen.
7. Put the cable interface plate in place and secure with the fixing screws.

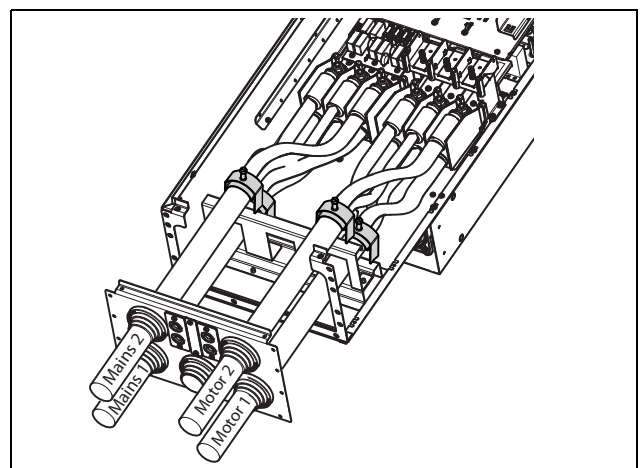

Fig. 54 All cables and cable clamps connected.

## Emotron VFX48-090 mount extra ferrite core

Mount the ferrite core and its isolation sheet (included in the delivery) on the three motor phases U, V & W. The protective earth (PE) and the screen of the cable should be mounted outside the core see Fig. 55.

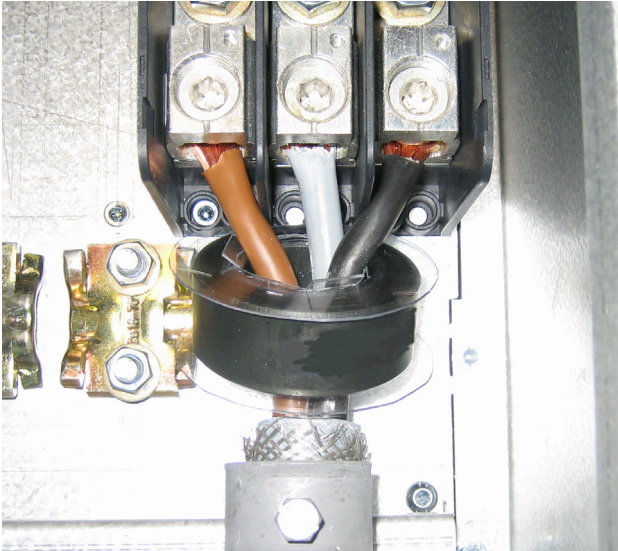

Fig. 55 Ferrite core mounted on the motor cables

The ferrite core is mounted on the motor cable to reduce disturbances and to fulfil the EMC standards. Since the core becomes very hot, the cables must be protected by a thermal isolation sheet that is attached on the core. The longer motor cables the hotter the core becomes.

**NOTE:** If the core is not mounted or mounted incorrect, the AC drive does not fulfil the EMC standards. If the protective isolation sheet is not mounted, the motor cable can be damaged from the hot core.

## AC drive model 48-430 and 69-250 and up

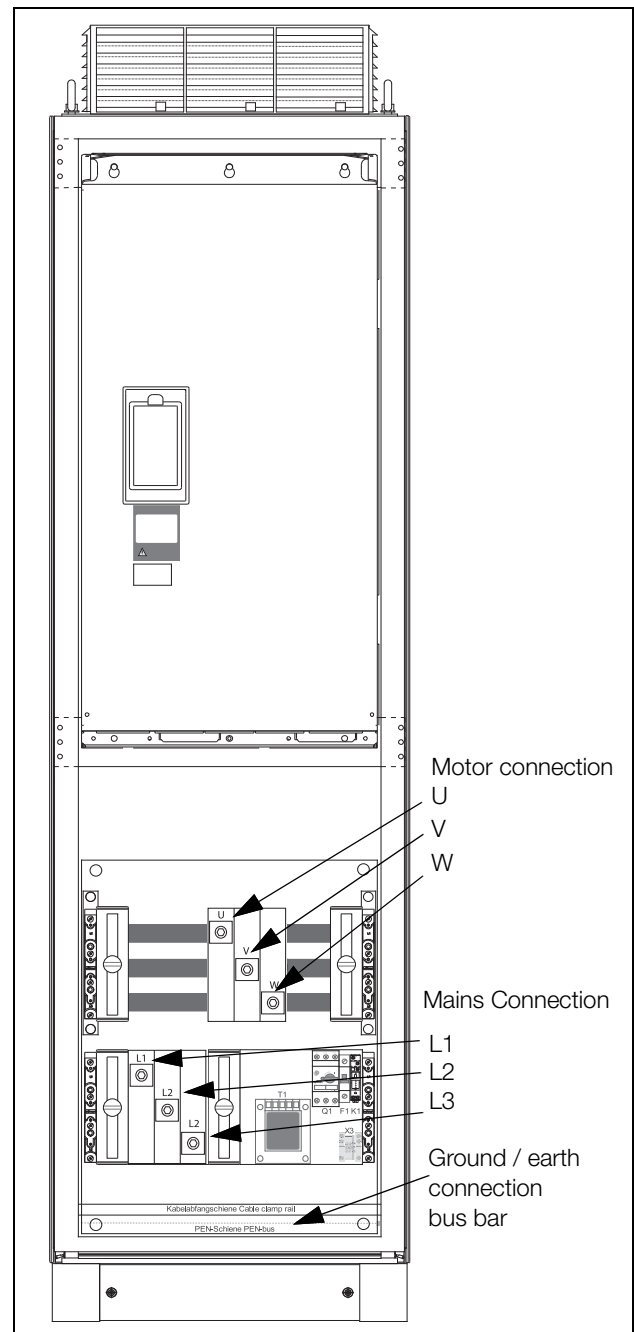

Fig. 56 Connect motor cables and mains cables to the terminals and earth/ground to the bus bar.

AC drive models 48-430 and 69-250 and up are supplied with power clamps for mains and motors. For connection of PE and earth there is a grounding bus bar.

For all type of wires to be connected the stripping length should be 32 mm (1.26 in).

### 3.3.1 Connection of mains and motor cables on IP20 modules

The Emotron IP 20 modules are delivered complete with factory mounted cables for mains and motor. The length of the cables are app. 1100 mm (43 in). The cables are marked L1, L2, L3 for mains connection and U, V, W for motor connection.

**NOTE:** The IP20 modules are connected to PE/ Ground via the mounting screws. Make sure that these will have good contact to the grounded mounting plate/ cabinet wall.

For detailed information about use of the IP20 modules, please contact CG Drives & Automation.

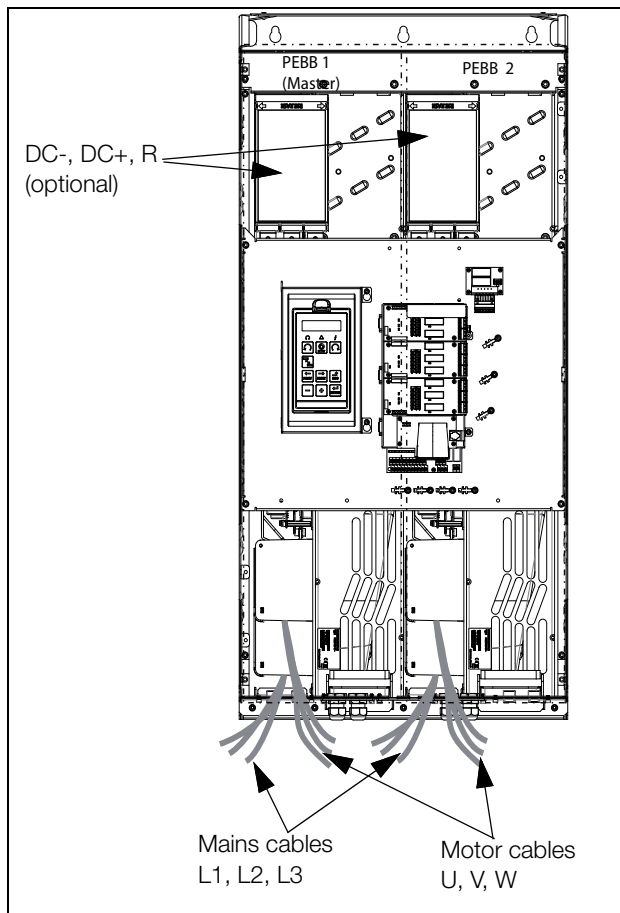

Fig. 57 IP20 module sizes H, H2 and G2 with qty 2 x 3 mains cables and qty 2 x 3 motor cables.

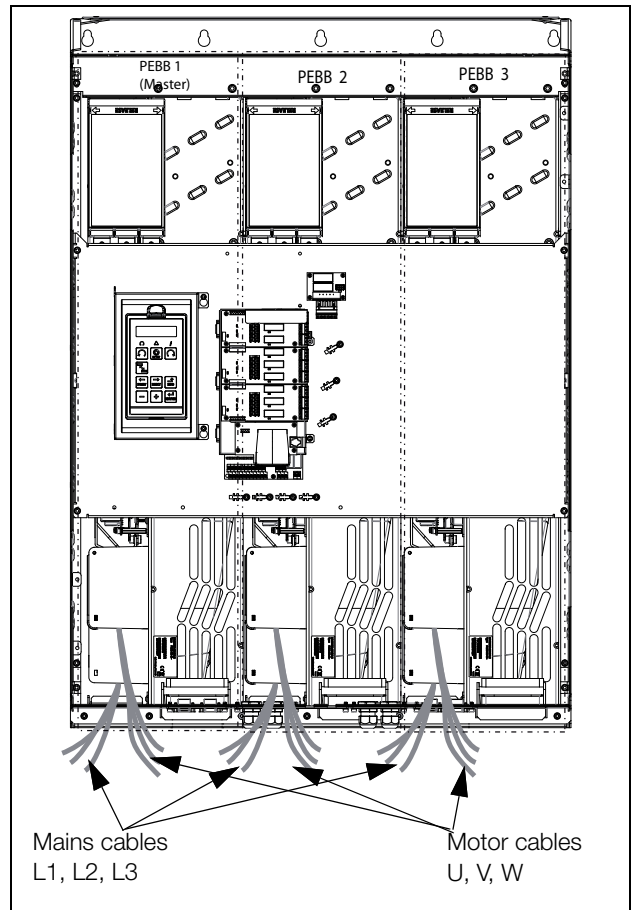

Fig. 58 IP20 module sizes G3/H3/I69 with qty 3 x 3 Mains cables and qty 3 x 3 motor cables.

## 3.4 Cable specifications

Table 14 Cable specifications

Cable	Cable specification
Mains	Power cable suitable for fixed installation for the voltage used.
Motor	Symmetrical three conductor cable with concentric protection (PE) wire or a four conductor cable with compact low-impedance concentric shield for the voltage used.
Control	Control cable with low-impedance shield, screened.

### 3.4.1 Stripping lengths

Fig. 59 indicates the recommended stripping lengths for motor and mains cables.

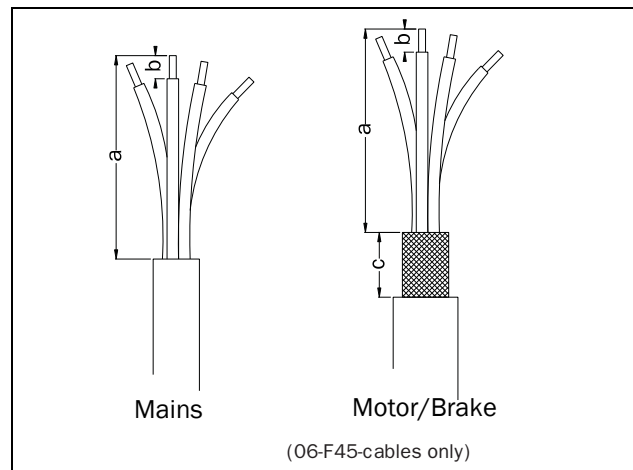

Fig. 59 Stripping lengths for cables

Table 15 Stripping lengths for mains, motor, brake and earth cables for frame sizes B to F

Model VFX	Frame size	Mains cable		Motor cable			Brake cable			Earth cable	
		a mm (in)	b mm (in)	a mm (in)	b mm (in)	c mm (in)	a mm (in)	b mm (in)	c mm (in)	a mm (in)	b mm (in)
##-003 – 018	B	90 (3.5)	10 (0.4)	90 (3.5)	10 (0.4)	20 (0.8)	90 (3.5)	10 (0.4)	20 (0.8)	90 (3.5)	10 (0.4)
##-026 – 046	C	150 (5.9)	14 (0.2)	150 (5.9)	14 (0.2)	20 (0.8)	150 (5.9)	14 (0.2)	20 (0.8)	150 (5.9)	14 (0.2)
69-002 – 025	C69										
69-002 – 025	C2(69)	65 (2.7)	18 (0.7)	65 (2.7)	18 (0.7)	36 (1.4)	65 (2.7)	18 (0.7)	36 (1.4)	65 (2.7)	M6 screw*
48-025 – 058	C2										
##-061 – 074	D	110 (4.3)	17 (0.7)	110 (4.3)	17 (0.7)	34 (1.4)	110 (4.3)	17 (0.7)	34 (1.4)	110 (4.3)	17 (0.7)
69-033 – 058	D69										
69-033 – 058	D2(69)	92 (3.6)	18 (0.7)	92 (3.6)	18 (0.7)	36 (1.4)	92 (3.6)	18 (0.7)	36 (1.4)	92 (3.6)	M6 screw*
48-060 – 105	D2										
##-090 – 175	E	173 (6.8)	25 (1)	173 (6.8)	25 (1)	41 (1.6)	173 (6.8)	25 (1)	41 (1.6)	173 (6.8)	25 (1) 40 (1.6)**
48-142 – 171	E2										
48-205 – 293	F2	178 (7)	32 (1.3)	178 (7)	32 (1.3)	46 (1.8)	178 (7)	25 (1)	46 (1.8)	178 (7)	32 (1.3) 40 (1.6)**
48-210 – 295	F										
69-082 – 200	F69										

\* Cable lug.

\*\* Valid when brake chopper electronics are built in

Fig. 60 indicates the distance from the cable clamp to the connection bolts for decision of stripping lengths for the cables.

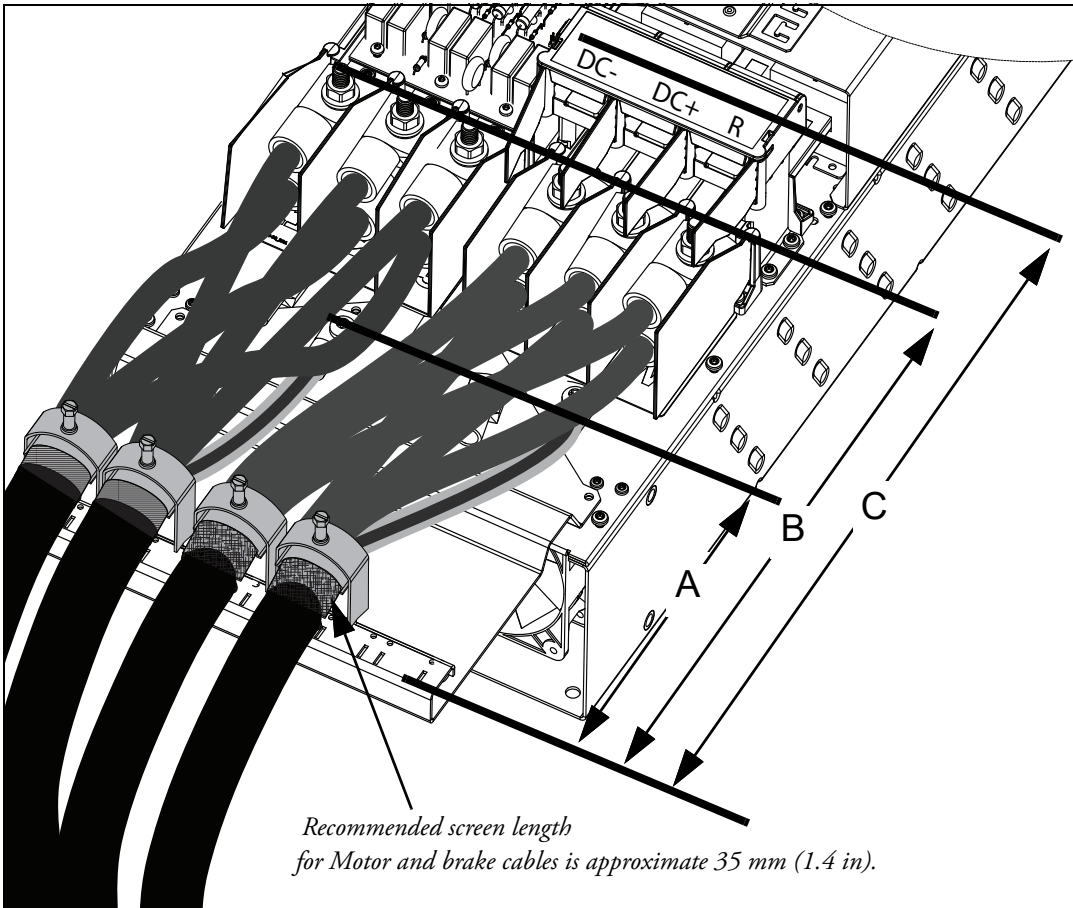

Fig. 60 Distances from the cable clamp to the connection bolts size FA2.

Table 16 Distances from the cable clamp to the connection bolts for mains, motor, brake and earth cables for frame size FA2.

Model VFX	Frame size	Mains cable		Motor cable		Brake cable		Earth cable	
		B mm (in)	Bolt dimension	B mm (in)	Bolt dimension	C mm (in)	Bolt dimension	A mm (in)	Bolt dimension
48-365-20	FA2	375 (14.8)	M10 bolt*	375 (14.8)	M10 bolt*	420 (16.5)	M8 bolt*	270 (10.6)	M8 bolt*

\* Connect with cable lugs.

Fig. 61 indicates the distance from the cable clamp to the connection bolts for decision of stripping lengths for the cables.

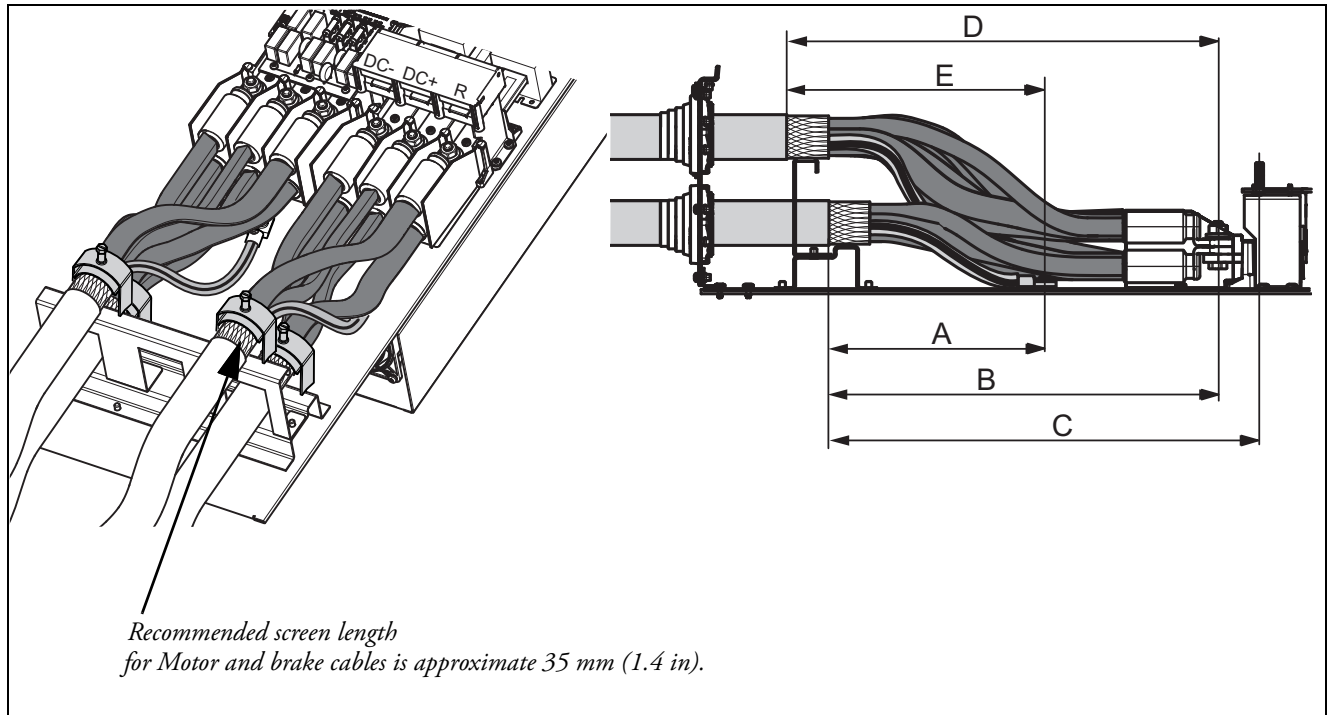

Fig. 61 Distances from the cable clamp to the connection bolts size FA.

Table 17 Distances from the cable clamp to the connection bolts for mains, motor, brake and earth cables for frame size FA.

Model VFX	Frame size	Mains cable 1		Motor cable 1		Brake cable		Earth cable	
		B mm (in)	Bolt dimension	B mm (in)	Bolt dimension	C mm (in)	Bolt dimension	A mm (in)	Bolt dimension
48-365-54	FA	360 (14.2)	M10 bolt*	360 (14.2)	M10 bolt*	400 (15.7)	M8 bolt*	270 (10.6)	M8 bolt*

Model VFX	Frame size	Mains cable 2		Motor cable 2		Earth cable	
		D mm (in)	Bolt dimension	D mm (in)	Bolt dimension	E mm (in)	Bolt dimension
48-365-54	FA	400 (15.7)	M10 bolt*	400 (15.7)	M10 bolt*	320 (12.6)	M8 bolt*

\* Connect with cable lugs.

### 3.4.2 Fuse data

Please refer to the chapter Technical data, Section 14.6, page 244.

### 3.4.3 Cable connection data for mains, motor and PE cables according to IEC ratings

**NOTE:** The dimensions of the power terminals used in the cabinet drive models 300 to 3K0 can differ depending on customer specification.

Table 18 Cable connector range and tightening torque for Emotron VFX48 and VFX52, according to IEC ratings.

Model VFX	Frame size	Cable cross section connector range						Cable type
		Mains and motor		Brake		PE		
		Cable area mm <sup>2</sup>	Tightening torque Nm	Cable area mm <sup>2</sup>	Tightening torque Nm	Cable area mm <sup>2</sup>	Tightening torque Nm	
##-003-54	B	0.5 - 10	1.2-1.4	0.5 - 10	1.2-1.4	1.5 - 16	2.6	Copper (Cu) / Aluminum (Al) 75°C
##-004-54								
##-006-54								
##-008-54								
##-010-54								
##-013-54								
##-018-54								
48-025-20	C2	4 - 25	2	4 - 25	2	4 - 25 *	4.3	
48-030-20								
48-036-20								
48-045-20								
48-058-20								
##-026-54	C	2.5-16 stranded 2.5-25 solid	1.2-1.4	2.5-16 stranded 2.5-25 solid	1.2-1.4	6-16 stranded 6-25 solid	1.2-1.4	
##-031-54								
##-037-54								
##-046-54								
48-060-20	D2	0.75 -50	3.3	0.75 -50	3.3	10 - 70 *	4.3	
48-072-20	D2	0.75 -50	3.3	0.75 -50	3.3	10 - 70 *	4.3	
48-088-20		16 - 50	7.9	16 - 50	7.9			
48-105-20								
##-061-54	D	6-35 stranded 6-50 solid	2.8-3	6-35 stranded 6-50 solid	2.8-3	16-35 stranded 16-50 solid	2.8-3	
##-074-54								
48-142-20	E2	16- 150	31 (for 16-34 mm <sup>2</sup> )	16 - 120	31 (for 16-34 mm <sup>2</sup> )	16- 150	31 (for 16-34 mm <sup>2</sup> )	
48-171-20								
48-090-54	E		42 (for 35-150 mm <sup>2</sup> ) ****	42 (for 35-120 mm <sup>2</sup> ) ****	16 - 185 **	16 - 185 **	42 (for 35-150 mm <sup>2</sup> )	
48-109-54								
48-146-54								
48-175-54								
						10 **		

Table 18 Cable connector range and tightening torque for Emotron VFX48 and VFX52, according to IEC ratings.

Model VFX	Frame size	Cable cross section connector range						Cable type					
		Mains and motor		Brake		PE							
		Cable area mm <sup>2</sup>	Tightening torque Nm	Cable area mm <sup>2</sup>	Tightening torque Nm	Cable area mm <sup>2</sup>	Tightening torque Nm						
48-205-20	F2	25 - 240	31 (for 25-34 mm <sup>2</sup> )	16 - 150	31 (for 16-34 mm <sup>2</sup> )	25 - 240	31 (for 25-34 mm <sup>2</sup> )	Copper (Cu) / Aluminum (Al) 75°C					
48-244-20			42 (for 35-152 mm <sup>2</sup> )				42 (for 35-152 mm <sup>2</sup> )						
48-293-20			56 (for 153-240 mm <sup>2</sup> ) ****				42 (for 35-150 mm <sup>2</sup> ) ****		16 - 185 **	56 (for 153-240 mm <sup>2</sup> )			
48-210-54	F										10 **	***	
48-250-54													
48-295-54													
48-365-20	FA2	M10 connection	47	M8 connection	24	M8 connection	24	Copper (Cu) / Aluminum (Al) 75°C					
48-365-54	FA												
48-430-54	H	(2x) 10 - 120	15	On request	On request	(6x) 16-70	15	Copper (Cu) / Aluminum (Al) 75°C					
48-500-54													
48-590-54	G2	(2x) 95-300	(6x) 70-185										
48-660-54	H2	(2x) 95-300							(6x) 70-185				
48-730-54			(9x) 70-185										
48-810-54	G3	(3x) 95-300	(9x) 70-185										
48-885-54													
48-1010-54	H3	(3x) 95-300	30						On request	On request	(9x) 70-185	15	Copper (Cu) / Aluminum (Al) 75°C
48-1100-54													
48-1300-54	H4	(4x) 95-300	30						On request	On request	(9x) 70-185	15	Copper (Cu) / Aluminum (Al) 75°C
48-1460-54													
48-1710-54	H5	(5x) 95-300	30						On request	On request	(12x) 70-185	15	Copper (Cu) / Aluminum (Al) 75°C
48-1820-54													
48-2190-54	H6	(6x) 95-300	30						On request	On request	(12x) 70-185	15	Copper (Cu) / Aluminum (Al) 75°C
48-2550-54	H7	(7x) 95-300											
48-2920-IP	H8	(8x) 95-300	30						On request	On request	(18x) 70-185	15	Copper (Cu) / Aluminum (Al) 75°C
											(18x) 70-185		
											(24x) 70-185		

\* With cable lug for M6 screw.

\*\* Valid when brake chopper electronics are built in.

\*\*\* Use 90 °C Mains and motor cables if surrounding temperature is higher than 35 °C otherwise 75 °C cables.

\*\*\*\* Cable lug tightening torque = 20 Nm, when terminal lug removed.

Table 19 Cable connector range and tightening torque for Emotron VFX69, according to IEC ratings

Model VFX	Frame size	Cable cross section connector range						Cable type
		Mains and motor		Brake		PE		
		Cable area mm <sup>2</sup>	Tightening torque Nm	Cable area mm <sup>2</sup>	Tightening torque Nm	Cable area mm <sup>2</sup>	Tightening torque Nm	
69-002-XX *****	C69/ C2(69)	2.5 - 16 stranded 2.5 - 25 solid	1.2 - 1.4	2.5 - 16 stranded 2.5 - 25 solid	1.2 - 1.4	6 - 16 stranded 6 - 25 solid	1.2 - 1.4	Copper (Cu)/ Aluminum (Al) 75°C
69-003-XX								
69-004-XX								
69-006-XX								
69-008-XX								
69-010-XX								
69-013-XX								
69-018-XX								
69-021-XX								
69-025-XX								
69-033-XX	D69/ D2(69)	6 - 35 stranded 10 - 50 solid	2.8 - 3	6 - 35 stranded 10-50 solid	2.8 - 3	6 - 35 stranded 10 - 50 solid	2.8 - 3	Copper (Cu)/ Aluminum (Al) 75°C
69-042-XX								
69-050-XX								
69-058-XX								
69-082-54	F69	16 - 150	31 (for 16 - 34 mm <sup>2</sup> )  42 (for 35-150 mm <sup>2</sup> )	16 - 120	31 (for 16 - 34 mm <sup>2</sup> )  42 (for 35-120 mm <sup>2</sup> )	16 - 150  16 - 185 **	10 **	Copper (Cu)/ Aluminum (Al) 75°C
69-090-54								
69-109-54								
69-146-54								
69-175-54								
69-200-54								

Table 19 Cable connector range and tightening torque for Emotron VFX69, according to IEC ratings

69-250-54	H69	(2x) 25 - 240	31 (for 25-34 mm <sup>2</sup> )	(2x) 25 - 240	31 (for 25-34 mm <sup>2</sup> )	PE/Earth via mounting screws/mounting frame. In order to secure proper earthing, always use all mounting screws and tighten them thoroughly.	Copper (Cu)/ Aluminum (Al) 75°C
69-300-54							
69-375-54							
69-400-54							
69-430-54	I69	(3x) 25 - 240	42 (for 35-152 mm <sup>2</sup> )	(3x) 25 - 240	42 (for 35-152 mm <sup>2</sup> )		
69-500-54							
69-595-54							
69-650-54	J69	(4x) 25 - 240	56 (for 153-240 mm <sup>2</sup> )	(4x) 25 - 240	56 (for 153-240 mm <sup>2</sup> )		
69-720-54							
69-800-54							
69-905-54	KA69	(5x) 25 - 240		(5x) 25 - 240			
69-995-54							
69-1k2-54	K69	(6x) 25 - 240		(6x) 25 - 240			
69-1k4-54	L69	(7x) 25 - 240		(7x) 25 - 240			
69-1k6-54	M69	(8x) 25 - 240		(8x) 25 - 240			
69-1k8-54	N69	(9x) 25 - 240		(9x) 25 - 240			
69-2k0-54	O69	(10x) 25 - 240		(10x) 25 - 240			
69-2k2-54	P69	(11x) 25 - 240		(11x) 25 - 240			
69-2k4-54	Q69	(12x) 25 - 240		(12x) 25 - 240			
69-2k6-54	R69	(13x) 25 - 240		(13x) 25 - 240			
69-2k8-54	S69	(14x) 25 - 240		(14x) 25 - 240			
69-3k0-54	T69	(15x) 25 - 240		(15x) 25 - 240			

\*\* Valid when brake chopper electronics are built in.

\*\*\*\*\* XX=20 or 54, module IP-class.

### 3.4.4 Cable connection data for mains, motor and PE cables according to NEMA ratings

List of cable cross section connector range with minimum required AWG cable cross section which fits to the terminals according to UL-requirements.

Table 20 Cable connector range and tightening torque for Emotron VFX48 and VFX52, according to NEMA ratings

Model VFX	Frame size	Cable cross section connector range						Cable type
		Mains and motor		Brake		PE		
		Cable range AWG	Tightening torque Lb-In	Cable range AWG	Tightening torque Lb-In	Cable range AWG	Tightening torque Lb-In	
##-003-54	B	20 - 8	11.5	20 - 8	11.5	16 - 6	23	Copper (Cu) 75°C
##-004-54								
##-006-54								
##-008-54								
##-010-54								
##-013-54								
##-018-54								
48-025-20	C2	12 - 4	18	12 - 4	18	12 - 4*	38	
48-030-20								
48-036-20								
48-045-20								
48-058-20								
##-026-54	C	18 - 4	10.6-12.3	18 - 4	10.6-12.3	18 - 4	10.6-12.3	
##-031-54								
##-037-54								
##-046-54								
48-060-20	D2	10 - 0	30 - 50	10 - 0	30 - 50	8 - 2/0*	38	
48-072-20	D2	10 - 0	30 - 50	10 - 0	30 - 50	8 - 2/0*	38	
48-088-20		3 - 2/0	70	3 - 2/0	70			
48-105-20								
##-061-54	D	10 - 0	24.3-26.1	10 - 0	24.3-26.1	10 - 0	24.3-26.1	
##-074-54								
48-142-20	E2	6 - 300 kcmil	275 (for AWG 6 - 2)	6 - 250 kcmil	275 (for AWG 6 - 2)	6 - 300 kcmil	275 (for AWG 6-2)	
48-171-20	E		375 (for AWG 1 - 300Kcmil)		375 (for AWG 1 - 250Kcmil)	6 - 2/0**	375 (for AWG 1-300Kcmil)	
48-090-54								
48-109-54								
48-146-54								
48-175-54								

Table 20 Cable connector range and tightening torque for Emotron VFX48 and VFX52, according to NEMA ratings

Model VFX	Frame size	Cable cross section connector range						Cable type			
		Mains and motor		Brake		PE					
		Cable range AWG	Tightening torque Lb-In	Cable range AWG	Tightening torque Lb-In	Cable range AWG	Tightening torque Lb-In				
48-205-20	F2	4 - 500 kcmil	275 (for AWG 4 - 2)	6 - 300 kcmil	275 (for AWG 6 - 2)	4 - 500 kcmil	275 (for AWG 4 - 2)	Copper (Cu) 75°C			
48-244-20											
48-293-20											
48-210-54											
48-250-54											
48-295-54	F		500 (for AWG 350 -500 kcmil)		375 (for AWG 1 -300Kcmil)	6 - 2/0**	500 (for AWG 350 -500 kcmil) 88**	***			
48-365-20	FA2	M10 connection	416	M8 connection	212	M8 connection	212	Copper (Cu) 75°C			
48-365-54	FA										
48-430-20	H	(2x) 4 - 500 kcmil	275 (for AWG 4 - 2) 375 (for AWG 1 - 300 kcmil)	(2x) 4 - 500 kcmil	275 (for AWG 4 - 2) 375 (for AWG 1 -300 kcmil)	For connecting PE/Earth cables, use M8 grounding bolts in the lower back part of the drive module mounting frame. Tightening torque = 212 Lb-In.	Copper (Cu) 75°C				
48-500-20			500 (for AWG 350 -500 kcmil)		500 (for AWG 350 -500 kcmil)						
48-590-20	G2	M10 connection	416	M10 connection	416	For connecting PE/Earth cables, use M8 grounding bolts in the lower back part of the drive module mounting frame. Tightening torque = 212 Lb-In.	Copper (Cu) 75°C				
48-660-20	H2										
48-730-20	H2										
48-810-20	G3										
48-885-20	G3										
48-1010-20	H3										
48-1100-20	H3										
48-1300-20	H4										
48-1460-20	H4										
48-1710-20	H5										
48-1820-20	H5										

Table 20 Cable connector range and tightening torque for Emotron VFX48 and VFX52, according to NEMA ratings

Model VFX	Frame size	Cable cross section connector range						Cable type
		Mains and motor		Brake		PE		
		Cable range AWG	Tightening torque Lb-In	Cable range AWG	Tightening torque Lb-In	Cable range AWG	Tightening torque Lb-In	
48-2190-20	H6	M10 connection	416	M10 connection	416	For connecting PE/Earth cables use M8 grounding bolts in the lower back part of the drive module mounting frame. Tightening torque = 212 Lb-In.		Copper (Cu) 75°C
48-2550-20	H7							
48-2920-20	H8							

\* With cable lug for M6 screw.

\*\* Valid when brake chopper electronics are built in.

\*\*\* Use 90 °C Mains and motor cables if surrounding temperature is higher than 35 °C otherwise 75 °C cables.

### 3.5 Thermal protection on the motor

Standard motors are normally fitted with an internal fan. The cooling capacity of this built-in fan is dependent on the frequency of the motor. At low frequency, the cooling capacity will be insufficient for nominal loads. Please contact the motor supplier for the cooling characteristics of the motor at lower frequency.



**WARNING!**  
Depending on the cooling characteristics of the motor, the application, the speed and the load, it may be necessary to use forced cooling on the motor.

Motor thermistors offer better thermal protection for the motor. Depending on the type of motor thermistor fitted, the optional PTC input may be used. The motor thermistor gives a thermal protection independent of the speed of the motor, thus of the speed of the motor fan. See the functions, Motor  $I^2t$  type [231] and Motor  $I^2t$  current [232].

### 3.6 Motors in parallel

The Drive Mode "Speed" or "Torque", see menu [213], performs very well in most applications based on the direct torque control as motor control method. However in applications with multiple motors connected in parallel to the AC drive output one should select Drive Mode = "V/Hz" and then it is possible to have motors in parallel as long as the total current does not exceed the nominal value of the AC drive. The following has to be taken into account when setting the motor data:

Menu [221] Motor Voltage:	The motors in parallel must have the same motor voltage.
Menu [222] Motor Frequency:	The motors in parallel must have the same motor frequency.
Menu [223] Motor Power:	Add the motor power values for the motors in parallel.
Menu [224] Motor Current:	Add the current for the motors in parallel.
Menu [225] Motor Speed:	Set the average speed for the motors in parallel.
Menu [227] Motor Cos PHI:	Set the average Cos PHI value for the motors in parallel.

## 4. Control Connections

### 4.1 Control board

Fig. 62 shows the layout of the control board which is where the parts most important to the user are located. Although the control board is galvanically isolated from the mains, for safety reasons do not make changes while the mains supply is on!



**WARNING!**  
Always switch off the mains voltage and wait at least 7 minutes to allow the DC capacitors to discharge before connecting the control signals or changing position of any switches. If the option External supply is used, switch of the mains to the option. This is done to prevent damage on the control board.

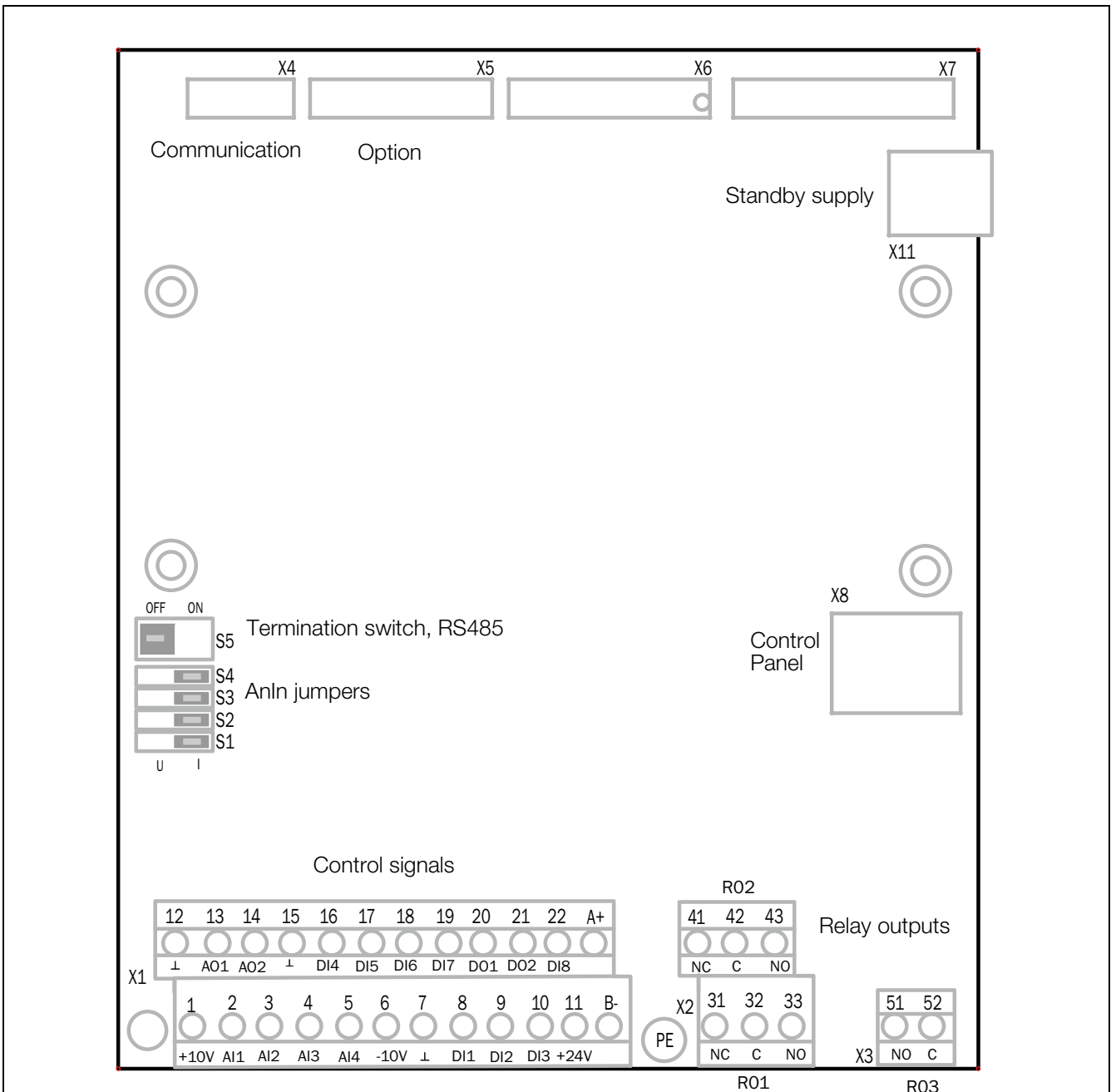

Fig. 62 Control board layout.

## 4.2 Terminal connections

The terminal strip for connecting the control signals is accessible after opening the front panel.

The table describes the default functions for the signals. The inputs and outputs are programmable for other functions as described in Chapter 11, page 99. For signal specifications refer to Chapter 14, page 231.

**NOTE: The maximum total combined current for outputs 11, 20 and 21 is 100mA.**

**NOTE: It is possible to use external 24V DC if connection to Common (15).**

Table 21 Control signals

Terminal	Name	Function (Default)
Outputs		
1	+10 V	+10 VDC supply voltage
6	-10 V	-10 VDC supply voltage
7	Common	Signal ground
11	+24 V	+24 VDC supply voltage
12	Common	Signal ground
15	Common	Dig signal ground *
Digital inputs		
8	DigIn 1	RunL (reverse)
9	DigIn 2	RunR (forward)
10	DigIn 3	Off
16	DigIn 4	Off
17	DigIn 5	Off
18	DigIn 6	Off
19	DigIn 7	Off
22	DigIn 8	RESET
Digital outputs		
20	DigOut 1	Ready
21	DigOut 2	Brake
Analogue inputs		
2	AnIn 1	Process Ref
3	AnIn 2	Off
4	AnIn 3	Off
5	AnIn 4	Off
Analogue outputs		
13	AnOut 1	Min speed to max speed
14	AnOut 2	0 to max torque

Table 21 Control signals

Terminal	Name	Function (Default)
Integrated RS-485 <sup>1</sup>		
A+	A+	RS-485 Differential transmit and receive
B-	B-	
Relay outputs		
31	N/C 1	Relay 1 output Trip, active when the AC drive is in a TRIP condition.
32	COM 1	
33	N/O 1	
41	N/C 2	Relay 2 output Run, active when the AC drive is started.
42	COM 2	
43	N/O 2	
51	COM 3	Relay 3 output Off
52	N/O 3	

\* Digital signal ground connected to 0V via ferrite (600 Ohm @ 100MHz).

<sup>1</sup> The integrated RS-485 interface is a isolated interface supporting Modbus RTU protocol with baudrates ranging from 2400 bit/s up to 115.2 kbit/s. Termination and fail-safe can be activated via switch S5 when applicable. Note that proper termination and fail-safe is critical for a stable RS-485 network. It is recommended to use screened RS-485 cable which protects the signals from EMI. The cable screen should (in normal cases) be connected to inverter PE via provided screen clamps, see Fig. 63. For further information about Modbus RTU protocol and physical network connection see Emotron option manual for Serial communication RS-232/485 available on our website.

**NOTE: N/C is opened when the relay is active and N/O is closed when the relay is active.**

**NOTE! Using potentiometer for reference signal to Analogue input: Possible potentiometer value in range of 1 kΩ to 10 kΩ (¼ Watt) linear, where we advice to use a linear 1 kΩ / ¼ W type potentiometer for best control linearity.**



**WARNING!**

The relay terminals 31-52 are single isolated. Do NOT mix SELV voltage with e.g. 230 VAC on these terminals. A solution when dealing with mixed SELV/system voltage signals is to install an additional I/O board option (see Section 13.8 page 228) and connect all SELV voltage signals to the relay terminals of this option board while connecting all 230VAC signals to the control board relay terminals 31 - 52.

## 4.2.1 Stand by supply interface (SBS)

The control board mounted standby supply, X11 connector, provides the possibility of keeping the communication system up and running without having the 3-phase mains connected. Another advantage is that the system can be set up without mains power. The option will also give backup for communication failure if main power is lost.

The standby supply should be supplied with a 24 VDC  $\pm 10\%$  double isolated transformer capable of supplying 1A continuous current. Recommended fuse is 2A. Cable length limited to 30 m. If the cable is longer than 30 m, a shielded cable must be used.

Table 22 X11 terminal

Terminal	Name	Function
1	+	24 VDC $\pm 10\%$
2	-	0 V









**NOTE:** In case the isolated DC measurement board (that incorporate stand by supply [SBS] functionality) the control-board SBS should not be used. Rather the SBS on the isolated DC measurement board should be used. Failure to comply with this will break DC-link voltage measurement.

## 4.3 Configuration with jumpers and switches

### 4.3.1 Analogue input configuration (S1 - S4)

The jumpers selections S1 to S4 are used to set the input configuration for the 4 analogue inputs AnIn1, AnIn2, AnIn3 and AnIn4 as described in Table 23. See Fig. 62 for the location of the jumpers.

Table 23 Settings selectors S1-S4

Input	Signal type	Selector configuration
AnIn1	Voltage	S1 
	Current (default)	S1 
AnIn2	Voltage	S2 
	Current (default)	S2 
AnIn3	Voltage	S3 
	Current (default)	S3 
AnIn4	Voltage	S4 
	Current (default)	S4 



**NOTE:** Scaling and offset of AnIn1 - AnIn4 can be configured using the software. See menus [512], [515], [518] and [51B] in Section 11.4.3, page 170.

**NOTE:** the 2 analogue outputs AnOut 1 and AnOut 2 can be configured using the software. See menu [530] Section 11.5.3, page 179

### 4.3.2 RS-485 termination (S5)

Switch S5 is used to activate termination and fail-safe resistors for the integrated RS-485-interface on terminal X1: A+ and B-. See Fig. 62 for the location of the switch.

Table 24 Settings switch S5

Input	Termination	Selector S5 configuration
RS-485	OFF (def)	
	ON (Activated)	

---

**NOTE:** It is important to have termination and fail-safe activated on at least one node on the network to secure proper function. The termination shall **ONLY** be enabled in the cable ends of a RS-485 network. The termination resistor is used to avoid reflections of transmitted signals and the fail-safe resistors will keep A+ and B- terminals at a steady state when no node is transmitting. It is important not to enable any additional termination apart from the two in each cable end as it will impose as an additional load for a transmitting transceiver and may cause malfunctioning.

---

## 4.4 Connection example

Fig. 63 gives an overall view of a AC drive connection example.

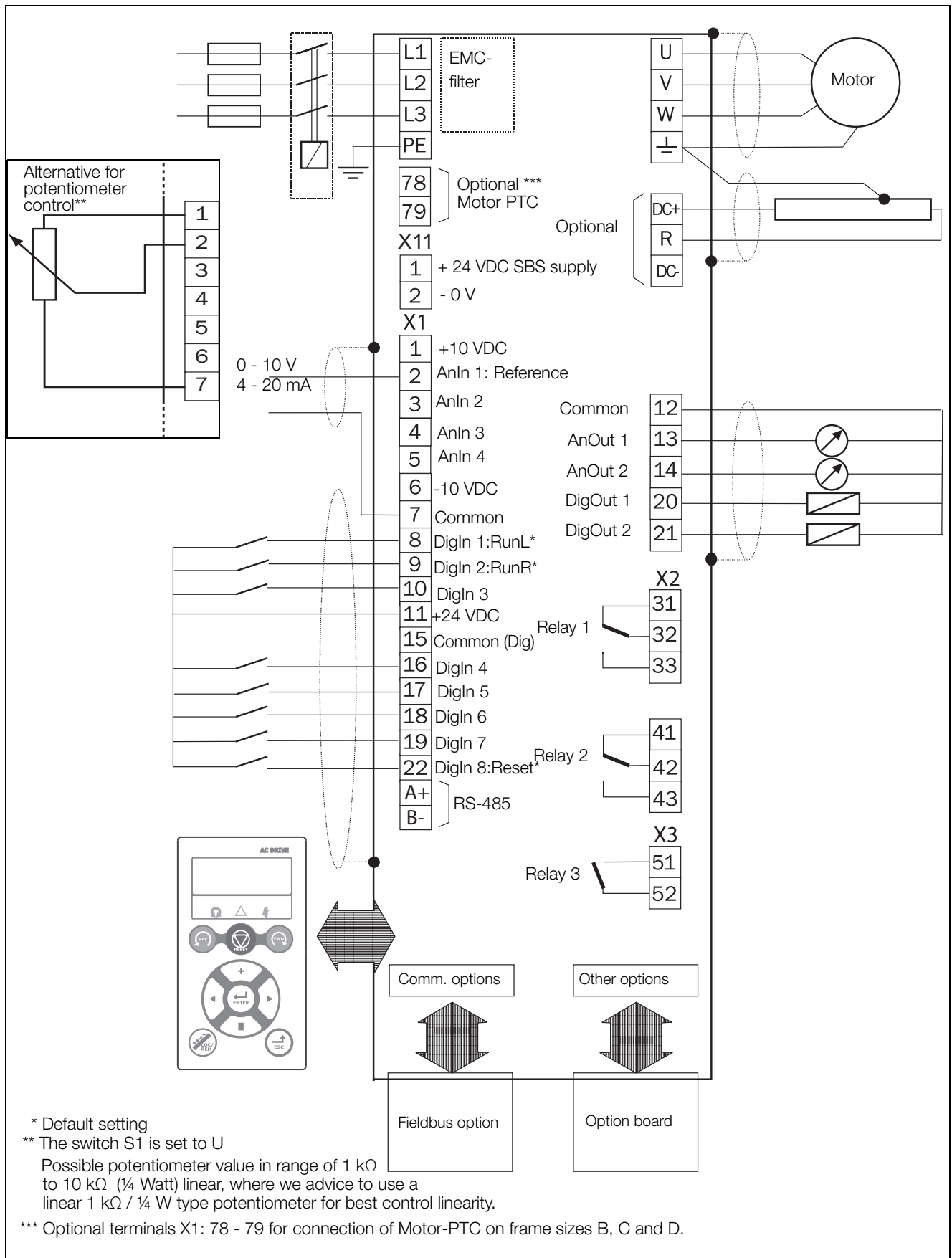

Fig. 63 Connection example.

## 4.5 Connecting the control signals

### 4.5.1 Cables

The standard control signal connections are suitable for stranded flexible wire up to 1.5 mm<sup>2</sup> (AWG16) and for solid wire up to 2.5 mm<sup>2</sup> (AWG14).

**NOTE:** The screening of control signal cables must comply with the immunity levels given in the EMC Directive (reduction of noise level).

**NOTE:** The control cables must be separated from motor and mains cables.

Table 25 Description of optional terminals in Fig. 64 to Fig. 68.

Terminals 78, 79	For connection of Motor PTC
------------------	-----------------------------

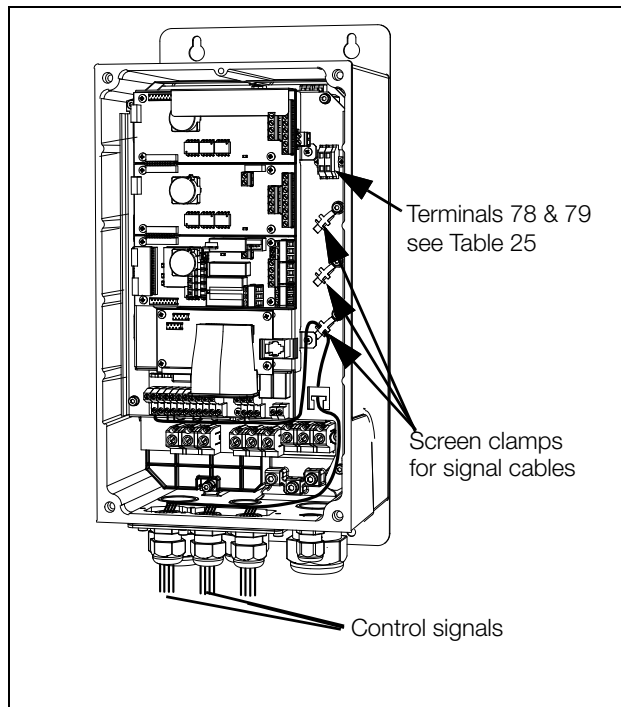

Fig. 64 Connecting the control signals, VFX model 003 to 018, frame size B.

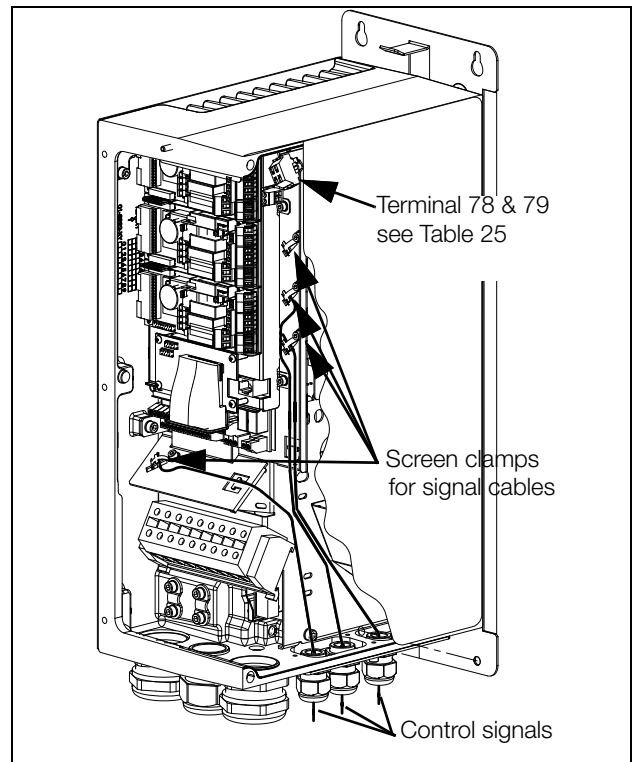

Fig. 65 Connecting the control signals, VFX model 026 to 046, frame size C.

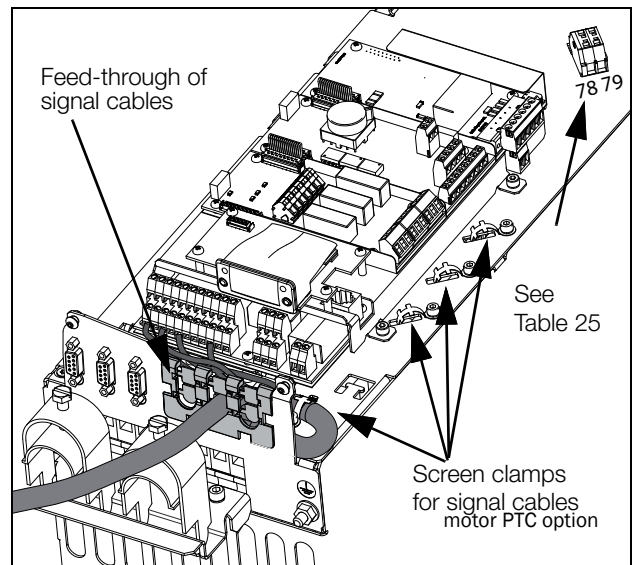

Fig. 66 Connecting the control signals, VFX model 48-025 to 48-058 frame size C2 and model 69-002 to 69-025 frame size C2(69).

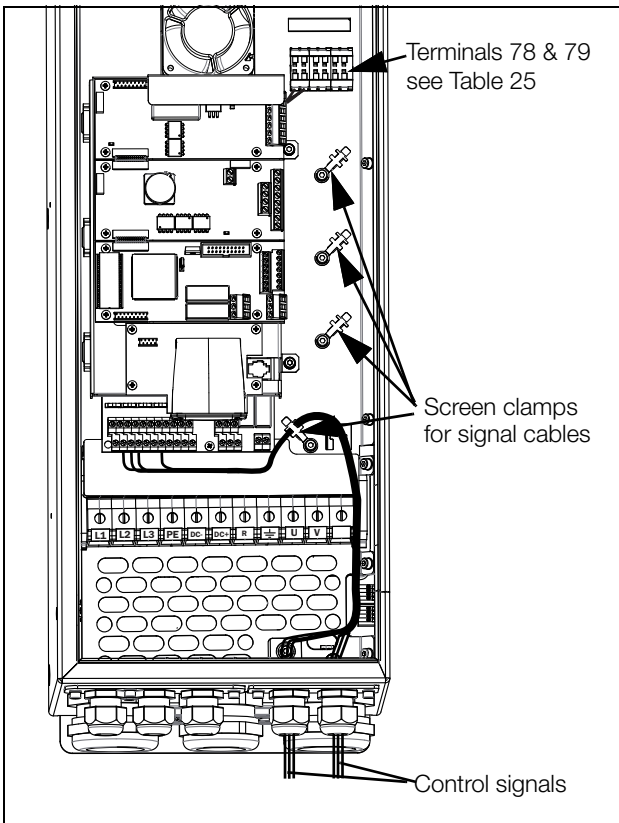

Fig. 67 Connecting the control signals, VFX model 061 to 074, frame size D and model 69-033 to 69-058 frame size D(69).

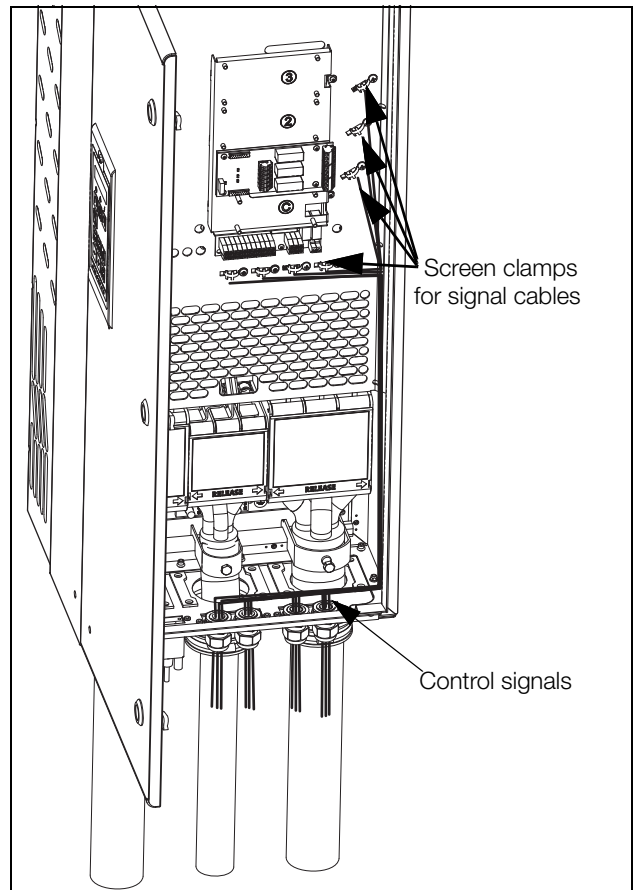

Fig. 69 Connecting the control signals, VFX model 48-090 to 295 and VFX model 69-82 to 200, frame size E, F and F69 (principle drawing).

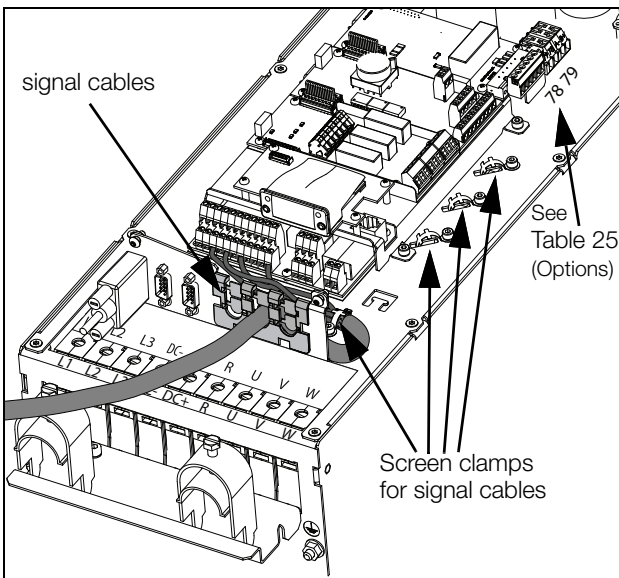

Fig. 68 Connecting the control signals, VFX model 48-060 to 48-105 frame size D2 and model 69-033 to 69-058 frame size D2(69).

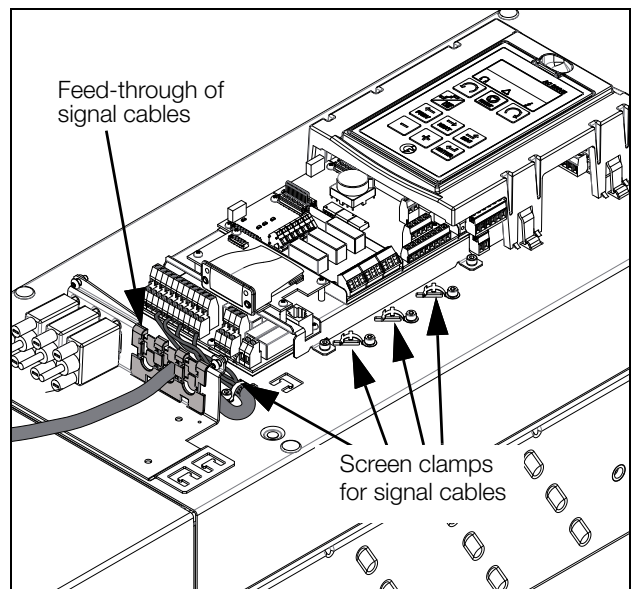

Fig. 70 Connecting the control signals, VFX model 48-142 to 48-365 frame size E2, F2 and FA2 (principle drawing).

---

**NOTE: The screening of control signal cables is necessary to comply with the immunity levels given in the EMC Directive (it reduces the noise level).**

---

**NOTE: Control cables must be separated from motor and mains cables.**

---

## 4.5.2 Types of control signals

Always make a distinction between the different types of signals. Because the different types of signals can adversely affect each other, use a separate cable for each type. This is often more practical because, for example, the cable from a pressure sensor may be connected directly to the AC drive.

We can distinguish between the following types of control signals:

### Analogue inputs

Voltage or current signals, (0-10 V, 0/4-20 mA) normally used as control signals for speed, torque and PID feedback signals.

### Analogue outputs

Voltage or current signals, (0-10 V, 0/4-20 mA) which change slowly or only occasionally in value. In general, these are control or measurement signals.

### Digital

Voltage or current signals (0-10 V, 0-24 V, 0/4-20 mA) which can have only two values (high or low) and only occasionally change in value.

### Data

Usually voltage signals (0-5 V, 0-10 V) which change rapidly and at a high frequency, generally data signals such as RS-232, RS-485, Profibus, etc.

### Relay

Relay contacts (0-250 VAC) can switch highly inductive loads (auxiliary relay, lamp, valve, brake, etc.).

Signal type	Maximum wire size	Tightening torque	Cable type
Ana- logue	Rigid cable: 0.14-2.5 mm <sup>2</sup> (AWG 26 - 14)	0.5 Nm (4.4 LB- in)	Screened
Digital	Flexible cable: 0.14-1.5 mm <sup>2</sup> (AWG 26 - 16)		Screened
Data			Screened
Relay	Cable with ferrule: 0.25-1.5 mm <sup>2</sup> (AWG 24 - 16)		Not screened

## Example:

The relay output from a AC drive which controls an auxiliary relay can, at the moment of switching, form a source of interference (emission) for a measurement signal from, for example, a pressure sensor. Therefore it is advised to separate wiring and screening to reduce disturbances.

## 4.5.3 Screening

For all signal cables the best results are obtained if the screening is connected to both ends: the AC drive side and at the source (e.g. PLC, or computer). See Fig. 71.

It is strongly recommended that the signal cables be allowed to cross mains and motor cables at a 90° angle. Do not let the signal cable go in parallel with the mains and motor cable.

## 4.5.4 Single-ended or double-ended connection?

In principle, the same measures applied to motor cables must be applied to all control signal cables, in accordance with the EMC-Directives.

For all signal cables as mentioned in Section 4.5.2 the best results are obtained if the screening is connected to both ends. See Fig. 71.

---

**NOTE: Each installation must be examined carefully before applying the proper EMC measurements.**

---

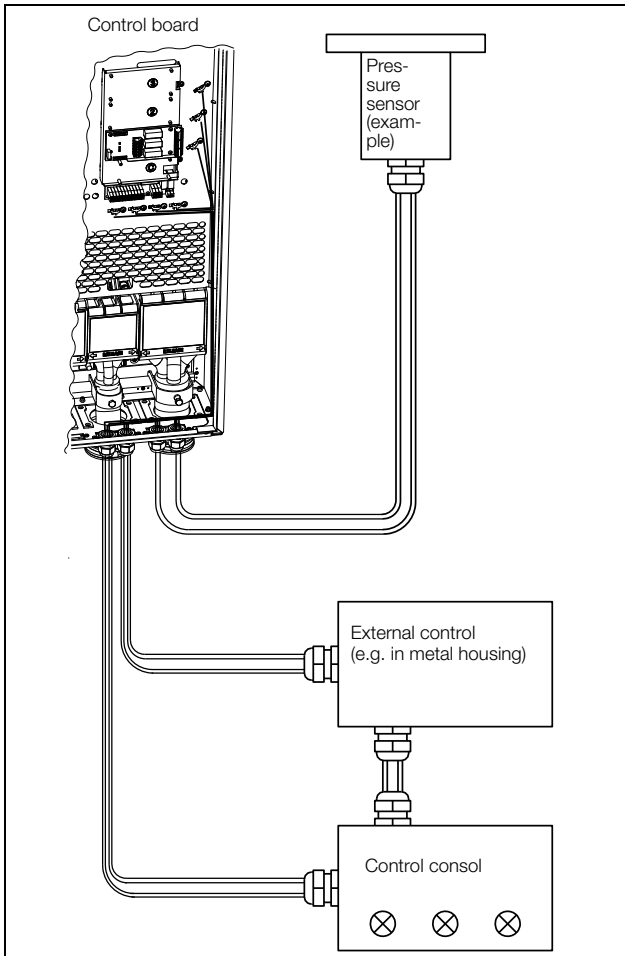

Fig. 71 Electro Magnetic (EM) screening of control signal cables.

## 4.6 Connecting options

The option cards are connected by the optional connectors X4 or X5 on the control board see Fig. 62, page 49 and mounted above the control board. The inputs and outputs of the option cards are connected in the same way as other control signals.

### 4.5.5 Current signals ((0)4-20 mA)

A current signal like (0)4-20 mA is less sensitive to disturbances than a 0-10 V signal, because it is connected to an input which has a lower impedance ( $250 \Omega$ ) than a voltage signal ( $20 \text{ k}\Omega$ ). It is therefore strongly advised to use current control signals if the cables are longer than a few metres.

### 4.5.6 Twisted cables

Analogue and digital signals are less sensitive to interference if the cables carrying them are “twisted”. This is certainly to be recommended if screening cannot be used. By twisting the wires the exposed areas are minimised. This means that in the current circuit for any possible High Frequency (HF) interference fields, no voltage can be induced. For a PLC it is therefore important that the return wire remains in proximity to the signal wire. It is important that the pair of wires is fully twisted over  $360^\circ$ .



# 5. Getting Started

This chapter is a step by step guide that will show you the quickest way to get the motor shaft turning. We will show you two examples, remote control and local control.

We assume that the AC drive is mounted on a wall or in a cabinet as in the Chapter 2. page 13.

First there is general information of how to connect mains, motor and control cables. The next section describes how to use the function keys on the control panel. The subsequent examples covering remote control and local control describe how to program/set the motor data and run the AC drive and motor.

## 5.1 Connect the mains and motor cables

Dimension the mains and motor cables according to local regulations. The cable must be able to carry the AC drive load current.

### 5.1.1 Mains cables

1. Connect the mains cables as in Fig. 72. The AC drive has, as standard, a built-in RFI mains filter that complies with category C3 which suits the Second Environment standard.

### 5.1.2 Motor cables

Connect the motor cables as in Fig. 72. To comply with the EMC directive you have to use screened cables and the motor cable screen has to be connected on both sides: to the housing of the motor and the housing of the AC drive.

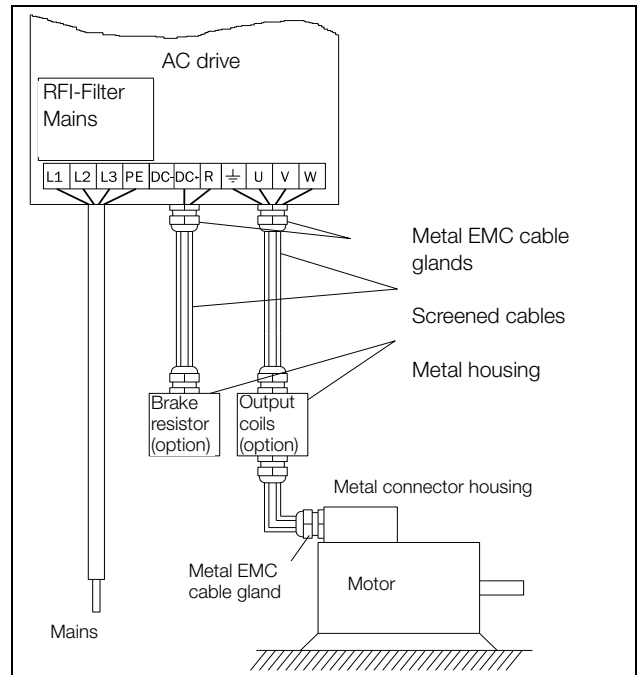



Fig. 72 Connection of mains and motor cables.

Table 26 Mains and motor connection

L1,L2,L3	Mains supply, 3 -phase
PE	Safety earth
	Motor earth
U, V, W	Motor output, 3-phase



**WARNING!**

In order to work safely the mains earth must be connected to PE and the motor earth to .

## 5.2 Using the function keys

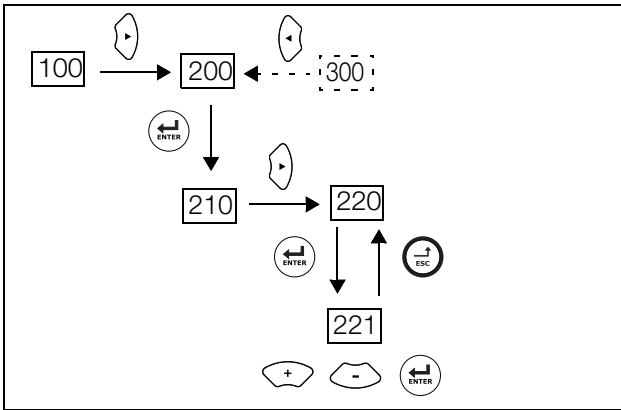

Fig. 73 Example of menu navigation when entering motor voltage.

	step to lower menu level or confirm changed setting
	step to higher menu level or ignore changed setting
	step to next menu on the same level
	step to previous menu on the same level
	increase value or change selection
	decrease value or change selection

## 5.3 Remote control

In this example external signals are used to control the AC drive/motor.

A standard 4-pole motor for 400 V, an external start button and a reference value will also be used.

### 5.3.1 Connect control cables

Here you will make up the minimum wiring for starting. In this example the motor/AC drive will run with right rotation.

To comply with the EMC standard, use screened control cables with plaited flexible wire up to 1.5 mm<sup>2</sup> (AWG15) or solid wire up to 2.5 mm<sup>2</sup>(AWG13).

2. Connect a reference value between terminals 7 (Common) and 2 (AnIn 1) as in Fig. 74.
3. Connect an external start button between terminal 11 (+24 VDC) and 9 (DigIn2, RUNR) as in Fig. 74.

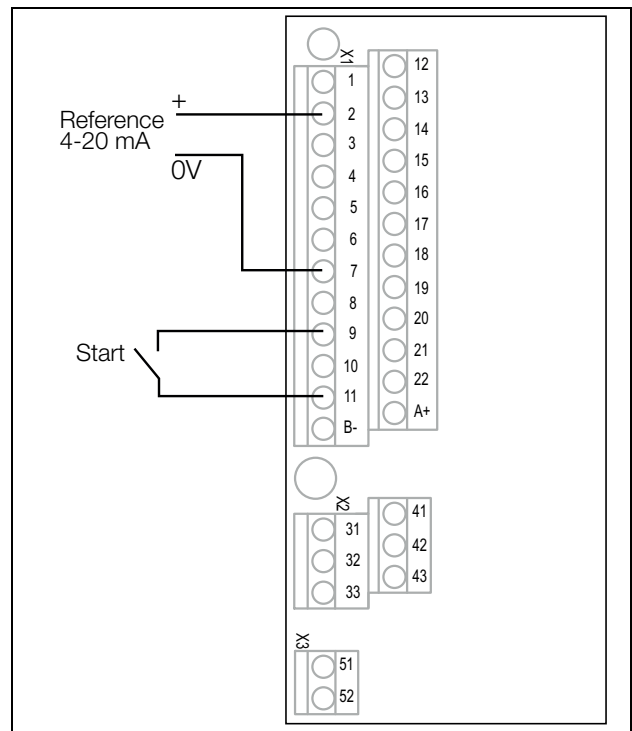

Fig. 74 Wiring.

### 5.3.2 Switch on the mains

Once the mains is switched on, the internal fan in the AC drive will run for 5 seconds.

### 5.3.3 Set the Motor Data

Enter correct motor data for the connected motor. The motor data is used in the calculation of complete operational data in the AC drive.

Change settings using the keys on the control panel. For further information about the control panel and menu structure, see the Chapter 10, page 91.

Menu [100], "Preferred View" is displayed when started.

1. Press to display menu [200], "Main Setup".
2. Press and then to display menu [220], "Motor Data".
3. Press to display menu [221] and set motor voltage.
4. Change the value using the and keys. Confirm with .
5. Set motor frequency [222].
6. Set motor power [223].
7. Set motor current [224].
8. Set motor speed [225].
9. Set power factor (cos φ) [227].
10. Select supply voltage level used [21B].
11. Set Motor type[221].
12. [229] Motor ID run: Choose Short, confirm with and give start command .

The AC drive will now measure some motor parameters. The motor makes some beeping sounds but the shaft does not rotate. When the ID run is finished after about one minute ("Test Run OK!" is displayed), press to continue.

13. Use AnIn1 as input for the reference value. The default range is 4-20 mA. If you need a 0-10 V reference value, change switch (S1) on control board.
14. Switch off power supply.
15. Connect digital and analogue inputs/outputs as in Fig. 74.
16. Ready!
17. Switch on power supply.

### 5.3.4 Run the AC drive

Now the installation is finished, and you can press the external start button to start the motor.

When the motor is running the main connections are OK.

## 5.4 Local control

Manual control via the control panel can be used to carry out a test run.

Use a 400 V motor and the control panel.

### 5.4.1 Switch on the mains

Once the mains is switched on, the AC drive is started and the internal fan will run for 5 seconds.

### 5.4.2 Select manual control

Menu [100], "Preferred View" is displayed when started.

1. Press to display menu [200], "Main Setup".
2. Press to display menu [210], "Operation".
3. Press to display menu [211], "Language".
4. Press to display menu [214], "Reference Control".
5. Select **Keyboard** using the key and press to confirm.
6. Press to get to menu [215], "Run/Stop Control".
7. Select **Keyboard** using the key and press to confirm.
8. Press to get to previous menu level and then to display menu [220], "Motor Data".

### 5.4.3 Set the Motor Data

Enter correct motor data for the connected motor.

9. Press to display menu [221].
10. Change the value using the and keys. Confirm with .
11. Press to display menu [222].
12. Repeat step 9 and 10 until all motor data is entered.
13. Press twice and then to display menu [100], Preferred View.

### 5.4.4 Enter a Reference Value

Enter a reference value.

14. Press until menu [300], "Process" is displayed.
15. Press to display menu [310], "Set/View reference" value.
16. Use the and keys to enter, for example, 300 rpm. We select a low value to check the rotation direction without damaging the application.

### 5.4.5 Run the AC drive

Press the key on the control panel to run the motor forward.

If the motor is running the main connections are OK.



## 6. Applications

This chapter contains tables giving an overview of many different applications/duties in which it is suitable to use AC drives from CG Drives & Automation. Further on you will find application examples of the most common applications and solutions.

### 6.1 Application overview

#### 6.1.1 Cranes

Challenge	Emotron VFX solution	Menu
Starting with heavy load is difficult and risky. Can lead to jerks causing swinging load.	Direct torque control, fast motor pre-magnetization and precise brake control gives instant yet soft start with heavy load.	331–338, 339, 351
Jerky movements can cause load to be dropped, jeopardizing safety of people and goods.	Deviation control immediately detects load change. Signals to parallel safety system to activate mechanical brakes.	3AB, 3AC
Crane is driven slowly when returning empty or with light load. Valuable time is lost.	Speed can be increased by field weakening.	343, 3AA, 3AD, 713
Braking with heavy load is difficult and risky. Can lead to jerks causing swinging load.	Direct torque control and vector brake gradually reduce speed to zero before mechanical brake is activated.	213, 33E, 33F, 33G
Operator starts braking long before end position to avoid jerks. Valuable time is lost.	System automatically stops crane at end position. Operator can safely drive at full speed.	3A2–3AA

#### 6.1.2 Crushers

Challenge	Emotron VFX solution	Menu
High start currents require larger fuses and cables, or for mobile crushers larger diesel generators.	Direct torque control reduces start current. Same fuses as those for the motor, or smaller generator.	331-338, 351
Difficult to start with heavy load.	Possible to boost torque at start to overcome initial torque peak.	351–353
Material that could cause damage gets into the crusher.	Load Curve Protection quickly detects deviation. Warning is sent or safety stop activated.	411–41C9
Process inefficiency due to e.g. broken feeder or worn jaw. Wasted energy, mechanical stress, and risk of process failure.	Load Curve Protection quickly detects deviation from normal load. Warning is sent or safety stop activated.	411–41B, 41C1–41C9

### 6.1.3 Mills

Challenge	Emotron VFX solution	Menu
High start currents require larger fuses and cables. Cause stress on equipment and higher energy cost.	Direct torque control reduces start current. Same fuses can be used as those required for the motor.	331-338, 350
Difficult to start with heavy load.	Possible to boost torque at start to overcome initial torque peak.	351-353
Material that could cause damage gets into the mill.	Load Curve Protection quickly detects deviation. Warning is sent or safety stop activated.	411-41C9
Process inefficiency due to broken or worn equipment. Energy wasted and risk of process failure.	Load Curve Protection quickly detects deviation. Warning is sent or safety stop activated.	411-41B, 41C1-41C9

### 6.1.4 Mixers

Challenge	Emotron VFX solution	Menu
High start currents require larger fuses and cables. Cause stress on equipment and higher energy cost.	Direct torque control reduces start current. Same fuses can be used as those required for the motor.	331-338, 350
Difficult to determine when mixing process is ready.	Built-in shaft power monitor determines when viscosity is right.	411-41B
Process inefficiency due to e.g. a damaged or broken blade. Energy wasted and risk of process failure.	Load Curve Protection quickly detects deviation. Warning is sent or safety stop activated.	411-41B, 41C1 -41C9

# 7. Main Features

This chapter contains descriptions of the main features of the AC drive.

## 7.1 Parameter sets

Parameter sets are used if an application requires different settings for different modes. For example, a machine can be used for producing different products and thus requires two or more maximum speeds and acceleration/deceleration times. With the four parameter sets different control options can be configured with respect to quickly changing the behaviour of the AC drive. It is possible to adapt the AC drive online to altered machine behaviour. This is based on the fact that at any desired moment any one of the four parameter sets can be activated during Run or Stop, via the digital inputs or the control panel and menu [241].

Each parameter set can be selected externally via a digital input. Parameter sets can be changed during operation and stored in the control panel.

**NOTE: The only data not included in the parameter set is Motor data 1-4, (entered separately), language, communication settings, selected set, local remote, and keyboard locked.**

### 7.1.1 Define parameter sets

When using parameter sets you first decide how to select different parameter sets. The parameter sets can be selected via the control panel, via digital inputs or via serial communication. All digital inputs and virtual inputs can be configured to select parameter set. The function of the digital inputs is defined in the menu [520].

Fig. 75 shows the way the parameter sets are activated via any digital input configured to Set Ctrl 1 or Set Ctrl 2.

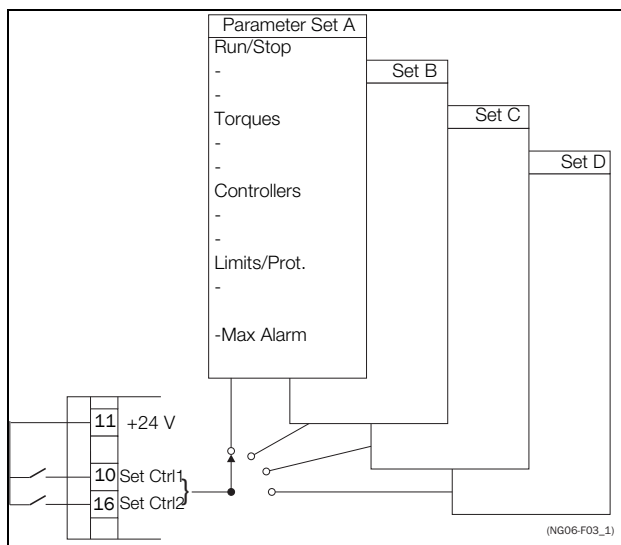

Fig. 75 Selecting the parameter sets.

### 7.1.2 Select and copy parameter set

The parameter set selection is done in menu [241], “Select Set”. First select the main set in menu [241], normally A. Adjust all settings for the application. Usually most parameters are common and therefore it saves a lot of work by copying set A>B in menu [242]. When parameter set A is copied to set B you only change the parameters in the set that need to be changed. Repeat for C and D if used.

With menu [242], Copy Set, it is easy to copy the complete contents of a single parameter set to another parameter set. If, for example, the parameter sets are selected via digital inputs, DigIn 3 is set to Set Ctrl 1 in menu [523] and DigIn 4 is set to Set Ctrl 2 in menu [524], they are activated as in Table 27.

Activate the parameter changes via digital input by setting menu [241], “Select Set” to DigIn.

Table 27 Parameter set

Parameter set	Set Ctrl 1	Set Ctrl 2
A	0	0
B	1	0
C	0	1
D	1	1

**NOTE: The selection via the digital inputs is immediately activated. The new parameter settings will be activated on-line, also during Run.**

**NOTE: The default parameter set is parameter set A.**

## Examples

Different parameter sets can be used to easily change the setup of a AC drive to adapt quickly to different application requirements. For example when

- a process needs optimized settings in different stages of the process, to
  - increase the process quality
  - increase control accuracy
  - lower maintenance costs
  - increase operator safety

With these settings a large number of options are available. Some ideas are given here:

## Multi frequency selection

Within a single parameter set the 7 preset references can be selected via the digital inputs. In combination with the parameter sets, 28 preset references can be selected using all 5 digital inputs: DigIn1, 2 and 3 for selecting preset reference within one parameter set and DigIn 4 and DigIn 5 for selecting the parameter sets.

## Bottling machine with 3 different products

Use 3 parameter sets for 3 different Jog reference speeds when the machine needs to be set up. The 4th parameter set can be used for “normal” remote control when the machine is running at full production.

## Product changing on winding machines

If a machine has to change between 2 or 3 different products e.g. winding machine with different gauges of thread, it is important that acceleration, deceleration times, Max Speed and Max Torque are adapted. For each thread size a different parameter set can be used.

## Manual - automatic control

If in an application something is filled up manually and then the level is automatically controlled using PID regulation, this is solved using one parameter set for the manual control and one for the automatic control.

## 7.1.3 One motor and one parameter set

This is the most common application for pumps and fans.

Once default motor M1 and parameter set A have been selected:

1. Enter the settings for motor data.
2. Enter the settings for other parameters e.g. inputs and outputs

## 7.1.4 One motor and two parameter sets

This application is useful if you for example have a machine running at two different speeds for different products.

Once default motor M1 is selected:

1. Select parameter set A in menu [241].
2. Enter motor data in menu [220].
3. Enter the settings for other parameters e.g. inputs and outputs.
4. If there are only minor differences between the settings in the parameter sets, you can copy parameter set A to parameter set B, menu [242].
5. Enter the settings for parameters e.g. inputs and outputs.

---

**Note: Do not change motor data in parameter set B.**

---

## 7.1.5 Two motors and two parameter sets

This is useful if you have a machine with two motors that can not run at the same time, such as a cable winding machine that lifts up the reel with one motor and then turns the wheel with the other motor.

One motor must stop before changing to an other motor.

1. Select parameter set A in menu [241].
2. Select motor M1 in menu [212].
3. Enter motor data and settings for other parameters e.g. inputs and outputs.
4. Select parameter set B in menu [241].
5. Select M2 in menu [212].
6. Enter motor data and settings for other parameters e.g. inputs and outputs.

## 7.1.6 Autoreset at trip

For several non-critical application-related failure conditions, it is possible to automatically generate a reset command to overcome the fault condition. The selection can be made in menu [250]. In this menu the maximum number of automatically generated restarts allowed can be set, see menu [2511], after this the AC drive will stay in fault condition because external assistance is required.

### Example

The motor is protected by an internal protection for thermal overload. When this protection is activated, the AC drive should wait until the motor is cooled down enough before resuming normal operation. When this problem occurs three times in a short period of time, external assistance is required.

The following settings should be applied:

- Insert maximum number of restarts; set menu [2511] to 3.
- Activate Motor I<sup>2</sup>t to be automatically reset; set menu [2533] to 300 s.
- Set relay 1, menu [550] to “AutoRst Trip”; a signal will be available when the maximum number of restarts is reached and the AC drive stays in fault condition.
- The reset input must be constantly activated.

## 7.1.7 Reference priority

The active speed reference signal can be programmed from several sources and functions. The table below shows the priority of the different functions with regards to the speed reference.

Table 28 Reference priority

Main Priority	Ref. selection	Priority
1. Jog, (menu [520], [348])	-	-
2. Reference selection, (menu [214])	Remote	1. Preset
		2. MotPot
		3. AnIn
	Keypad	-
	Com	-
	Option	-

## 7.1.8 Preset references

The AC drive is able to select fixed speeds via the control of digital inputs. This can be used for situations where the required motor speed needs to be adapted to fixed values, according to certain process conditions. Up to 7 preset references can be set for each parameter set, which can be selected via all digital inputs that are set to Preset Ctrl1, Preset Ctrl2 or Preset Ctrl3. The amount digital inputs used that are set to Preset Ctrl determines the number of Preset References available; using 1 input gives 1 speed, using 2 inputs gives 3 speeds and using 3 inputs gives 7 speeds.

### Example

The use of four fixed speeds, at 50 / 100 / 300 / 800 rpm, requires the following settings:

- Set DigIn 5 as first selection input; set [525] to Preset Ctrl1.
- Set DigIn 6 as second selection input; set [526] to Preset Ctrl2.
- Set menu [341] “Min Speed” to 50 rpm.
- Set menu [362] “Preset Ref 1” to 100 rpm.
- Set menu [363] “Preset Ref 2” to 300 rpm.
- Set menu [364] “Preset Ref 3” to 800 rpm.

With these settings, the AC drive switched on and a RUN command given, the speed will be:

- 50 rpm, when both DigIn 5 and DigIn 6 are low.
- 100 rpm, when DigIn 5 is high and DigIn 6 is low.
- 300 rpm, when DigIn 5 is low and DigIn 6 is high.
- 800 rpm, when both DigIn 5 and DigIn 6 are high.

## 7.2 Remote control functions

Operation of the Run/Stop/Enable/Reset functions

As default, all the run/stop/reset related commands are programmed for remote operation via the inputs on the terminal strip (terminals 1-22) on the control board. With the function “Run/Stop Ctrl” [215] and “Reset Control” [216], this can be selected for keyboard or serial communication control.

**NOTE:** The examples in this paragraph do not cover all possibilities. Only the most relevant combinations are given. The starting point is always the default setting (factory) of the AC drive.

### 7.2.1 Default settings of the Run/Stop/Enable/Reset functions

The default settings are shown in Fig. 76. In this example the AC drive is started and stopped with DigIn 2 and a reset after trip can be given with DigIn 8.

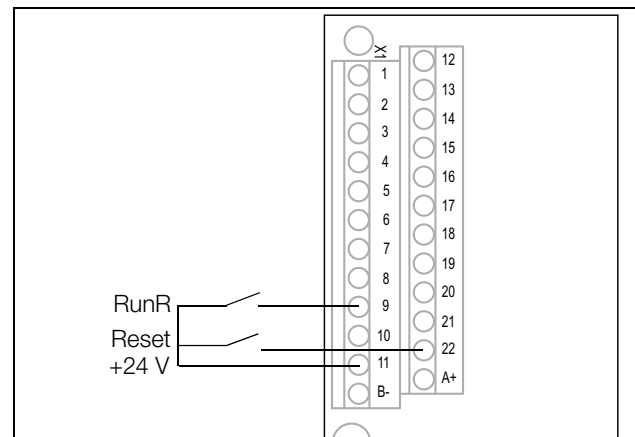

Fig. 76 Default setting Run/Reset commands.

The inputs are default set for level-control. The rotation is determined by the setting of the digital inputs.

### Enable and Stop functions

Both functions can be used separately or simultaneously. The choice of which function is to be used depends on the application and the control mode of the inputs (Level/Edge [21A]).

**NOTE:** In Edge mode, at least one digital input must be programmed to “stop”, because the Run commands are only able to start the AC drive.

## Enable

Input must be active (HI) to allow any Run signal. If the input is made LOW, the output of the AC drive is immediately disabled and the motor will coast.



**CAUTION!**  
If the Enable function is not programmed to a digital input, it is considered to be active internally.

## Stop

If the input is low then the AC drive will stop according to the selected stop mode set in menu [33B] "Stop Mode". Fig. 77 shows the function of the Enable and the Stop input and the Stop Mode=Decel [33B].

To run the input must be high.

**NOTE:** Stop Mode=Coast [33B] will give the same behaviour as the Enable input.

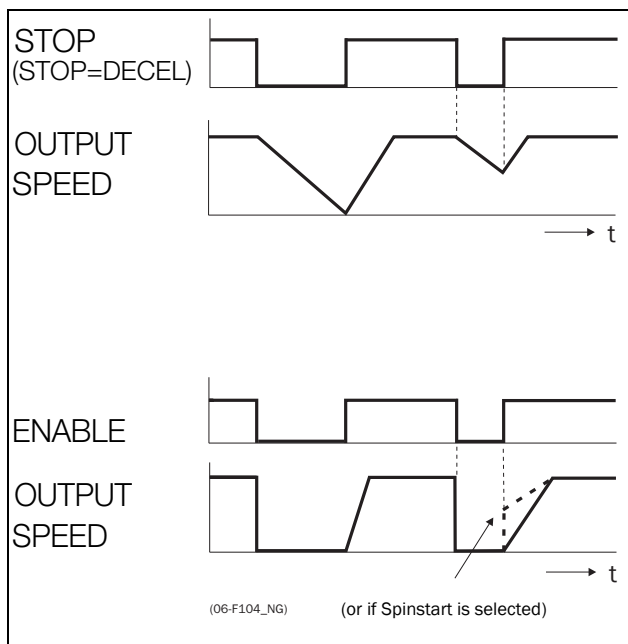

Fig. 77 Functionality of the Stop and Enable input.

## Reset and Autoreset operation

If the AC drive is in Stop Mode due to a trip condition, the AC drive can be remotely reset by a pulse ("low" to "high" transition) on the Reset input, default on DigIn 8.

Depending on the selected control method, a restart takes place as follows:

### Level-control

If the Run inputs remain in their position the AC drive will start immediately after the Reset command is given.

### Edge-control

After the Reset command is given a new Run command must be applied to start the AC drive again.

Autoreset is enabled if the Reset input is continuously active. The Autoreset functions are programmed in menu "Autoreset [250]".

**NOTE:** If the control commands are programmed for Keyboard control or Com, Autoreset is not possible.

## Run Inputs Level-controlled

The inputs are set as default for level-control. This means that an input is activated by making the input continuously "High". This method is commonly used if, for example, PLCs are used to operate the AC drive.



**CAUTION!**  
Level-controlled inputs DO NOT comply with the Machine Directive, if the inputs are directly used to start and stop the machine.

The examples given in this and the following paragraphs follow the input selection shown in Fig. 78.

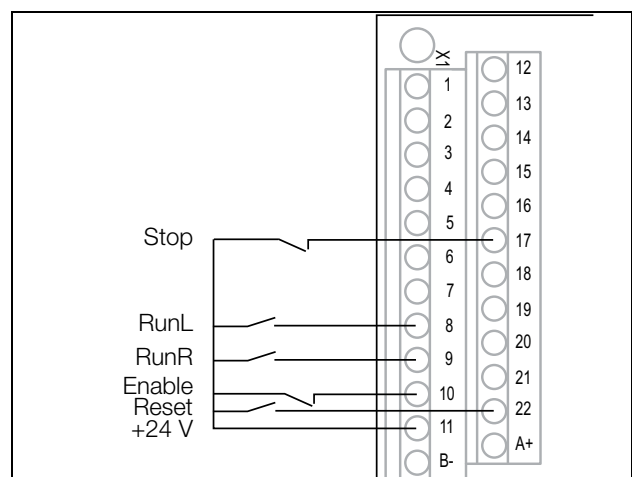

Fig. 78 Example of wiring for Run/Stop/Enable/Reset inputs.

The Enable input must be continuously active in order to accept any run-right or run-left command. If both RunR and RunL inputs are active, then the AC drive stops according to the selected Stop Mode. Fig. 79 gives an example of a possible sequence.

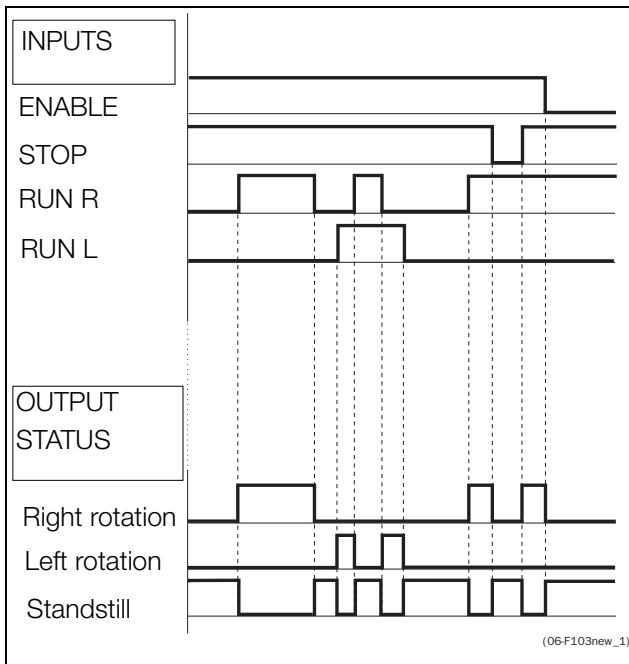

Fig. 79 Input and output status for level-control.

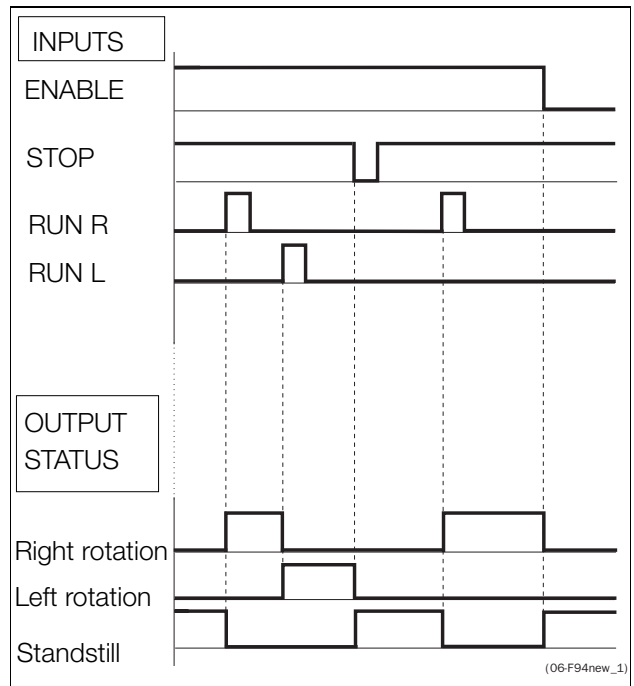

Fig. 80 Input and output status for edge-control.

### Run Inputs Edge-controlled

Menu “[21A] Start signal” Level/Edge must be set to Edge to activate edge control. This means that an input is activated by a “low” to “high” transition or vice versa.

**NOTE: Edge-controlled inputs comply with the Machine Directive (see Chapter 8, page 83), if the inputs are directly used for starting and stopping the machine.**

See Fig. 78. The Enable and Stop input must be active continuously in order to accept any run-right or run-left command. The last edge (RunR or RunL) is valid. Fig. 80 gives an example of a possible sequence.

## 7.3 Performing an Identification Run

To get the optimum performance out of your AC drive/motor combination, the AC drive must measure the electrical parameters (resistance of stator winding, etc.) of the connected motor. See menu [229] “Motor ID-Run”.

It is recommended that the extended ID run is used before the motor is installed in the application.

If this is not possible, the short ID run should be used.



### WARNING!

During the extended ID RUN, the motor shaft will rotate. Take safety measures to avoid unforeseen dangerous situations.

## 7.4 Using the Control Panel Memory

Data can be copied from the AC drive to the memory in the control panel and vice versa. To copy all data (including parameter set A-D and motor data) from the AC drive to the control panel, select Copy to CP [244], Copy to CP.

To copy data from the control panel to the AC drive, enter the menu [245], Load from CP and select what you want to copy.

The memory in the control panel is useful in applications with AC drives without a control panel and in applications where several AC drives have the same setup. It can also be used for temporary storage of settings. Use a control panel to upload the settings from one AC drive and then move the control panel to another AC drive and download the settings.

**NOTE:** Load from and copy to the AC drive is only possible when the AC drive is in stop mode.

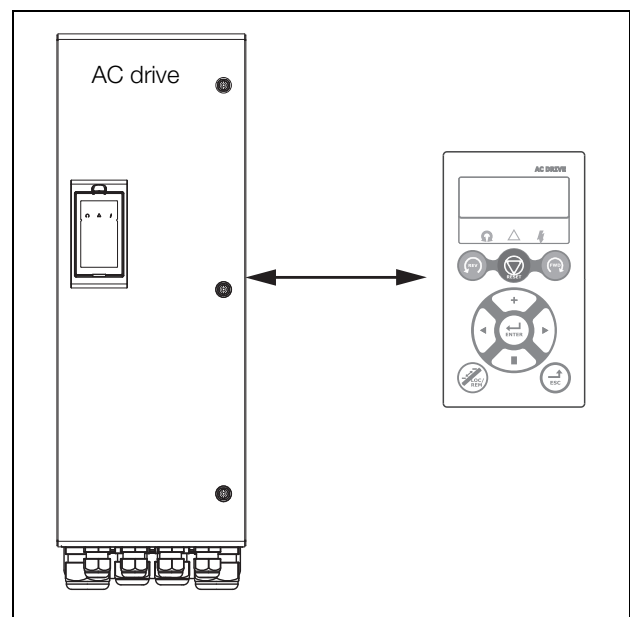

Fig. 81 Copy and load parameters between AC drive and control panel.

## 7.5 Load Monitor and Process Protection [400]

### 7.5.1 Load Monitor [410]

The monitor functions enable the AC drive to be used as a load monitor. Load monitors are used to protect machines and processes against mechanical overload and underload, such as a conveyer belt or screw conveyer jamming, belt failure on a fan or a pump dry running. The load is measured in the AC drive by the calculated motor shaft torque. There is an overload alarm (Max Alarm and Max Pre-Alarm) and an underload alarm (Min Alarm and Min Pre-Alarm).

The Basic Monitor type uses fixed levels for overload and underload (pre-)alarms over the whole speed range. This function can be used in constant load applications where the torque is not dependent on the speed, e.g. conveyer belt, displacement pump, screw pump, etc.

For applications with a torque that is dependent on the speed, the Load Curve monitor type is preferred. By measuring the actual load curve of the process, characteristically over the range of minimum speed to maximum speed, an accurate protection at any speed can be established.

The max and min alarm can be set for a trip condition. The pre-alarms act as a warning condition. All the alarms can be monitored on the digital or relay outputs.

The autosest function automatically sets the 4 alarm levels whilst running: maximum alarm, maximum pre-alarm, minimum alarm and minimum pre-alarm.

Fig. 82 gives an example of the monitor functions for constant torque applications.

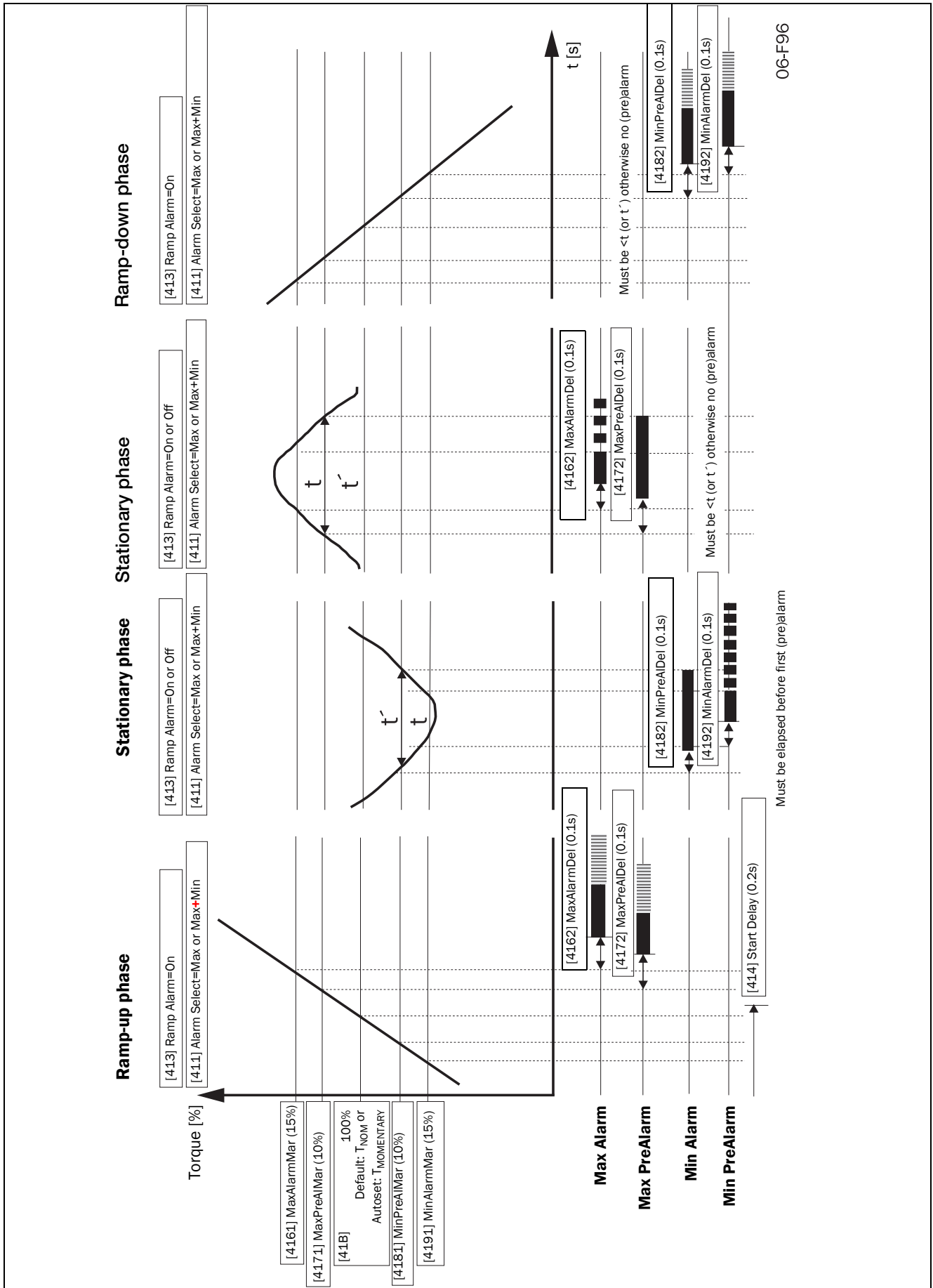

06-F96

Fig. 82

## 7.6 Emotron Dedicated Pump [390]

### 7.6.1 Introduction

A maximum of 4 pumps can be controlled with the standard AC drive.

If I/O Board options are installed, a maximum of 7 pumps can be controlled. The I/O Board can also be used as a general extended I/O.

The Pump Control function is used to control a number of drives (pumps, fans, etc., with a maximum of 3 additional drives per I/O-board connected) of which one is always driven by the AC drive. Other names for these kind of controllers are 'Cascade controller' or 'Hydrophore controller'.

Depending on the flow, pressure or temperature, additional pumps can be activated via the appropriate signals from the output relays of the AC drive and/or the I/O Board. The system is developed in such a way that one AC drive will be the master of the system.

Select a relay on the control board or on an option board. The relays are set to functions for controlling pumps. In the pictures in this section, the relays are named R:Function, e.g. R:SlavePump1, which means a relay on the control board or on a option board set to function SlavePump1.

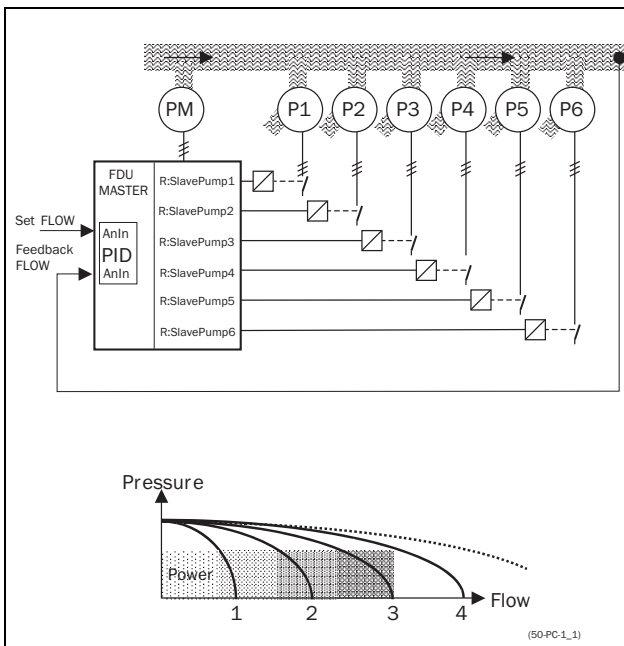

Fig. 83 Flow control with pump control option.

All additional pumps can be activated via an AC drive, soft starter, Y/ Δ or D.O.L. switches.

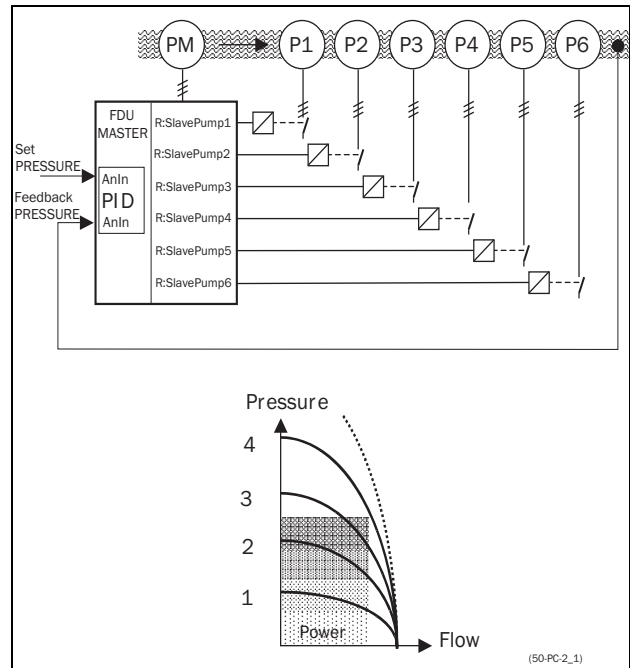

Fig. 84 Pressure control with pump control option.

Pumps in parallel will operate as a flow controller, See Fig. 83.

Pumps in a series will operate as a pressure controller see Fig. 84. The basic control principle is shown in Fig. 85.

**NOTE: Read this instruction manual carefully before commencing installation, connecting or working with the AC drive with Pump Control option.**

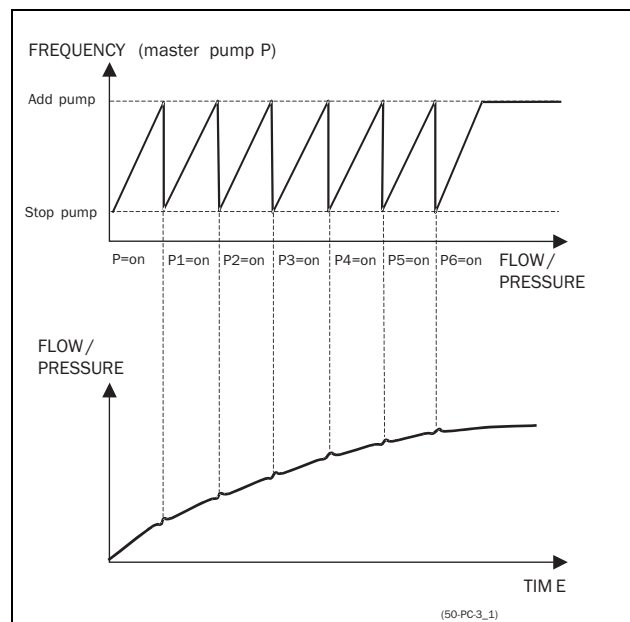

Fig. 85 Basic Control principle.

## 7.6.2 Fixed MASTER

This is the default setting of the Pump Control. The AC drive controls the Master pump which is always running. The relay outputs start and stop the other pumps P1 to P6, depending on flow/pressure. In this configuration, a maximum of 7 pumps can be controlled, see Fig. 86. To equalize the lifetime of the additional pumps it is possible to select the pumps depending on the run time history of each pump.

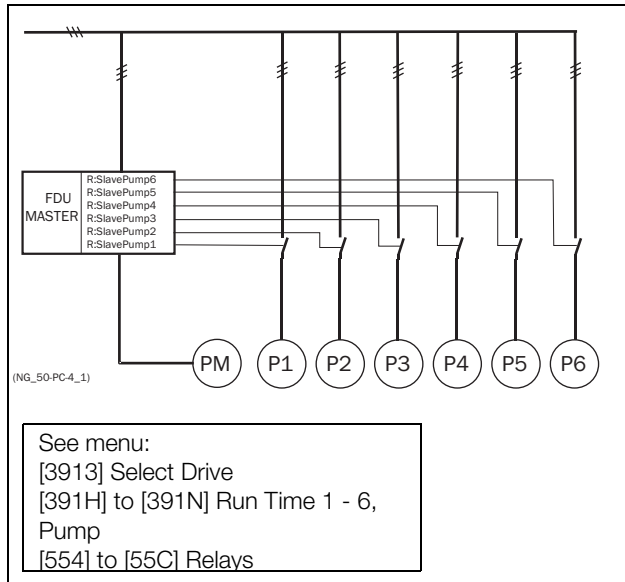

Fig. 86 Fixed MASTER control.

**NOTE: The pumps MAY have different powers, however the MASTER pump MUST always be the largest.**

## 7.6.3 Alternating MASTER

With this function the Master pump is not fixed to the AC drive all the time. After the AC drive is powered up or started again after a stop or sleep mode the Master pump is selected via the relay set to function Master Pump. Section 7.6.7, page 77 shows a detailed wiring diagram with 3 pumps. The purpose of this function is that all pumps are used equally, so the lifetime of all pumps, including the Master pump, will be equalized. Maximum 6 pumps can be controlled with this function.

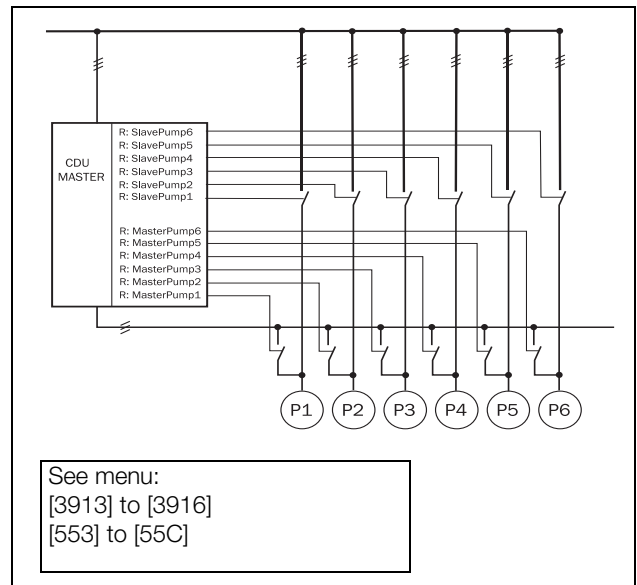

Fig. 87 Alternating MASTER Control.

**NOTE: The pumps MUST have all the same power.**

## 7.6.4 Feedback 'Status' input

In this example, the additional pumps are controlled by a different kind of drive (e.g. soft starter, frequency inverter, etc.). The digital inputs on the I/O Board can be programmed as a "Error" input for each pump. If a drive fails, the digital input will monitor this and the PUMP CONTROL option will not use that particular drive anymore and automatically switch to another drive. This means that the control continues without using this (faulty) drive. This function can also be used to manually stop a particular pump for maintenance purposes, without shutting down the whole pump system. Of course the maximum flow/pressure is then limited to the maximum pump power of the remaining pumps.

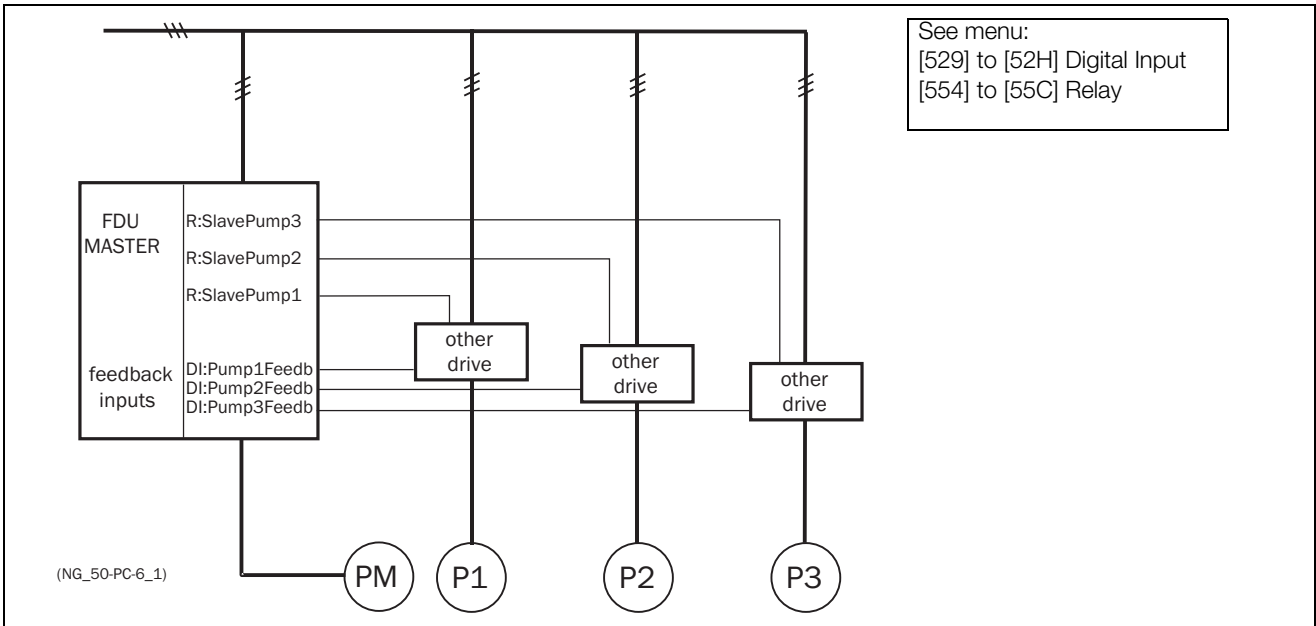

Fig. 88 Feedback "Status" input.

### 7.6.5 Fail safe operation

Some pump systems must always have a minimum flow or pressure level, even if the frequency inverter is tripped or damaged. So at least 1 or 2 (or maybe all) additional pumps must keep running after the inverter is powered down or tripped. This kind of "safe" pump operation can be

obtained by using the NC contacts of the pump control relays. These can be programmed for each individual additional pump. In this example, pumps P5 and P6 will run at maximum power if the inverter fails or is powered down.

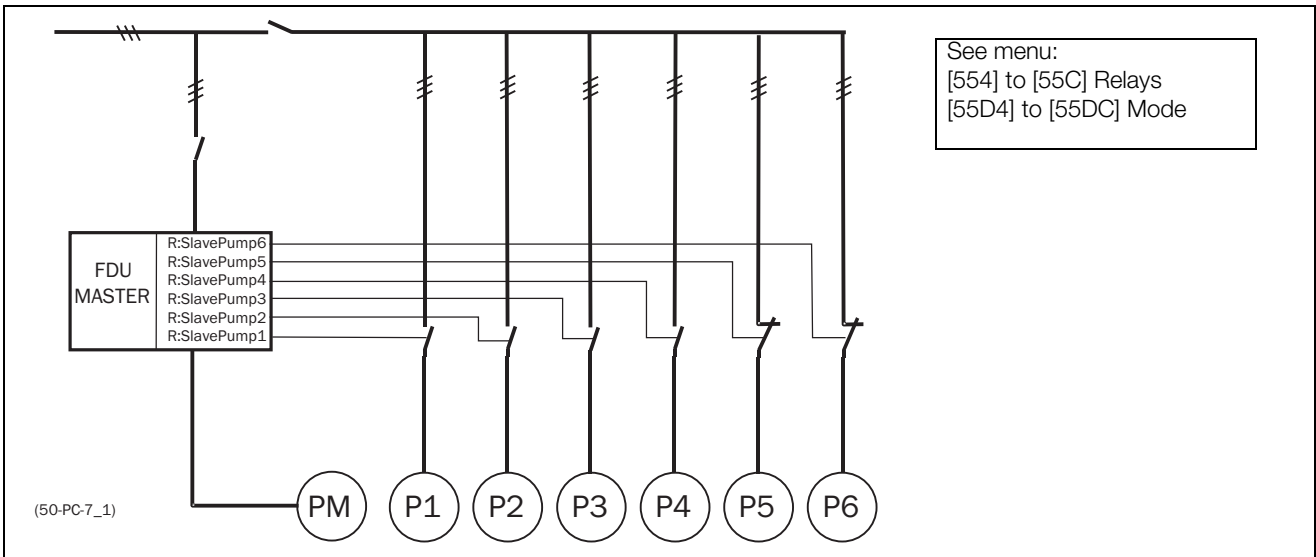

Fig. 89 Example of "Fail safe" operation.

## 7.6.6 PID control

When using the Pump Control option, it is mandatory to activate the PID controller function. Analogue inputs AnIn 1 to AnIn4 can be set as functions for PID set values and/or feedback values.

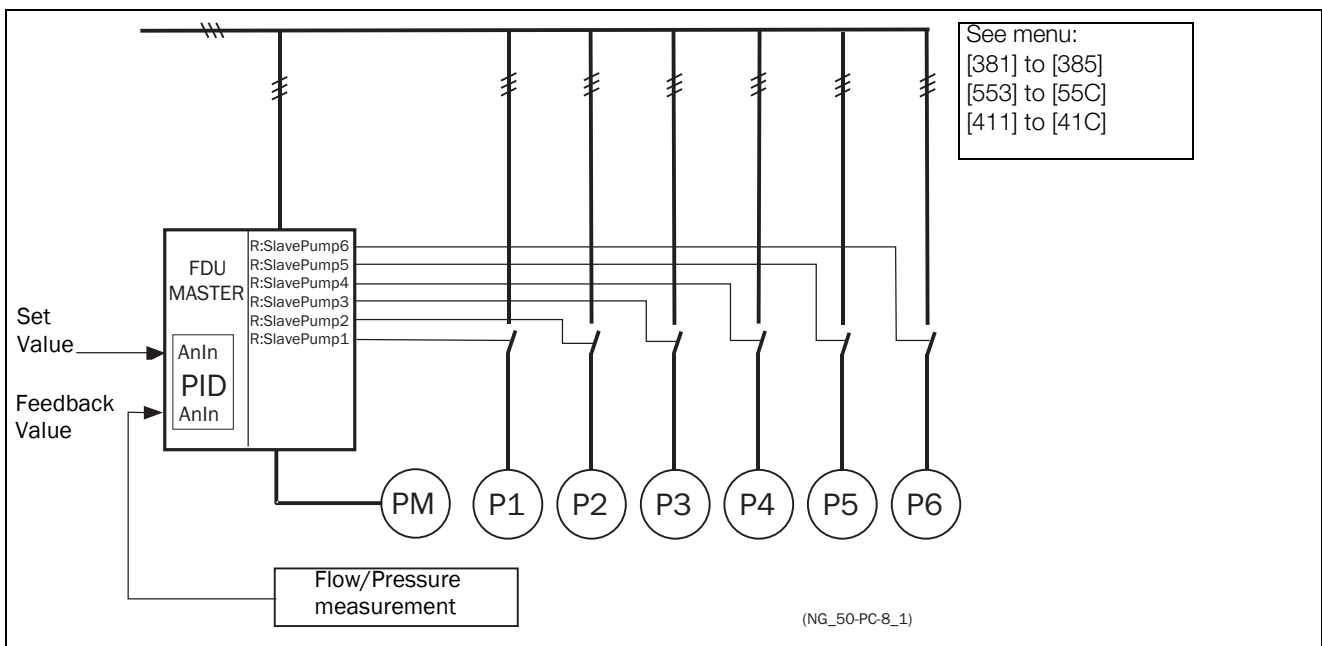

Fig. 90 PID control.

## 7.6.7 Wiring Alternating Master

Fig. 91 and Fig. 92 show the relay functions MasterPump1-6 and SlavePump1-6. The Master and Additional contactors also interlock with each other to prevent dual powering of the pump and damage to the inverter. (K1M/K1S, K2M/K2S, K3M/K3S). Before running, the VFX will select a pump to be Master, depending on the pump run times.



### CAUTION!

The wiring for the Alternating Master control needs special attention and should be wired exactly as described here, to avoid destructive short circuit at the output of the inverter.

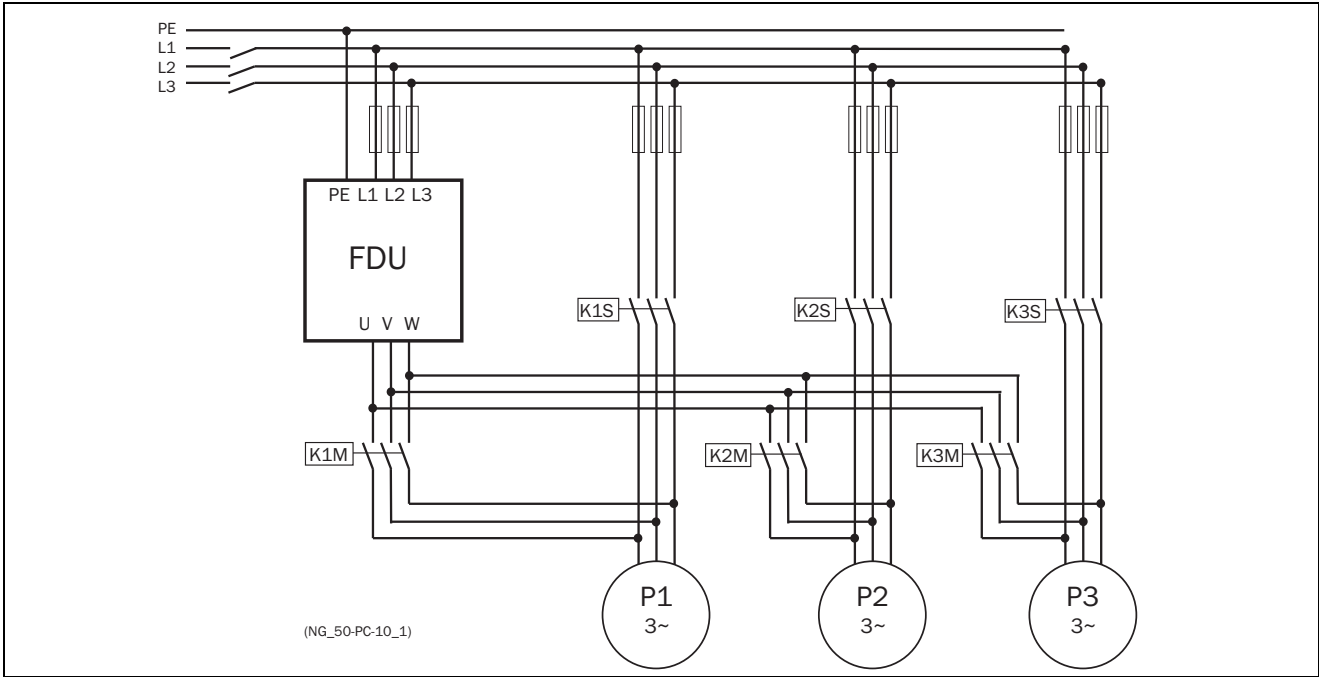

Fig. 91 Power connections for Alternating MASTER circuit with 3 pumps.

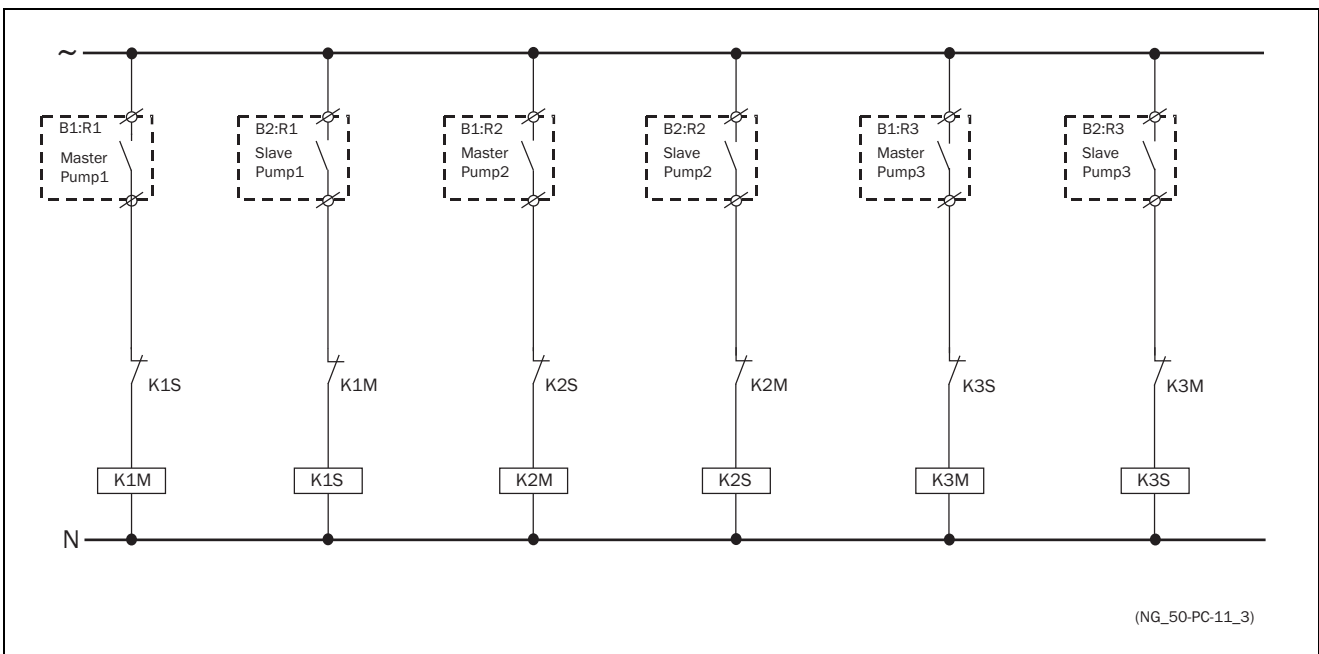

Fig. 92 Control connections for Alternating MASTER circuit with 3 pumps.

## 7.6.8 Checklist and tips

<b>1. Main Functions</b>	<p>Start by choosing which of the two main functions to use:</p> <ul style="list-style-type: none"><li>- "Alternating MASTER" function</li></ul> <p>In this case the "Master" pump can be alternated, although this function needs slightly more complicated wiring than the "Fixed MASTER" function described below. The I/O Board option is necessary.</p> <ul style="list-style-type: none"><li>- "Fixed MASTER" function:</li></ul> <p>One pump is always the master, only the additional pumps alternate.</p> <p>Notice that there is a big difference in the wiring of the system between these main functions, so it not possible to switch between these 2 functions later on. For further information see Section 7.6.2, page 74.</p>
<b>2. Number of pumps/drives</b>	<p>If the system consists of 2 or 3 pumps the I/O Board option is not needed. However, this does mean that the following functions are not then possible:</p> <ul style="list-style-type: none"><li>- "Alternating MASTER" function</li><li>- With isolated inputs</li></ul> <p>With the I/O Board option installed, the maximum number of pumps is:</p> <ul style="list-style-type: none"><li>- 6 pumps if "Alternating MASTER" function is selected. (see Section 7.6.3, page 74)</li><li>- 7 pumps if "Fixed MASTER" function is selected. (see Section 7.6.2, page 74)</li></ul>
<b>3. Pump size</b>	<ul style="list-style-type: none"><li>- "Alternating MASTER" function: The sizes of the pumps must be equal.</li><li>- "Fixed MASTER" function: The pumps may have different power sizes, but the master pump (VFX) must always have the greatest power.</li></ul>
<b>4. Programming the Digital inputs</b>	<p>If the digital inputs are used, the digital input function must be set to Drive feedback.</p>
<b>5. Programming the Relay outputs</b>	<p>After the Pump controller is switched on in menu [3911] the number of drives (pumps, fans, etc.) must be set in menu [3912] (Number of Drives). The relays themselves must be set to the function SlavePump1-6 and if Alternate master is used, MasterPump1-6 as well.</p>
<b>6. Equal Pumps</b>	<p>If all pumps are equal in power size it is likely that the Upper band is much smaller than the Lower band, because the maximum pump discharge of the master pump is the same if the pump is connected to the mains (50Hz). This can give a very narrow hysteresis causing an unstable control area in the flow/pressure. By setting the maximum frequency of the inverter only slightly above 50Hz it means that the master pump has a slightly bigger pump discharge than the pump on the mains. Of course caution is essential in order to prevent the master pump running at a higher frequency for a longer period of time, which in turn prevents the master pump from overloading.</p>
<b>7. Minimum Speed</b>	<p>With pumps and fans it is normal to use a minimum speed, because at lower speed the discharge of the pump or fan will be low until 30-50% of the nominal speed (depending on size, power, pump properties, etc.). When using a minimum speed, a much smoother and better control range of the whole system will be achieved.</p>

## 7.6.9 Functional Examples of Start/Stop Transitions

relay in this example starts the pump directly on line. Of course other start/stop equipment, like a soft starter, could be controlled by the relay output.

### Starting an additional pump

This figure shows a possible sequence with all levels and functions involved when a additional pump is started by means of the pump control relays. The starting of the second pump is controlled by one of the relay outputs. The

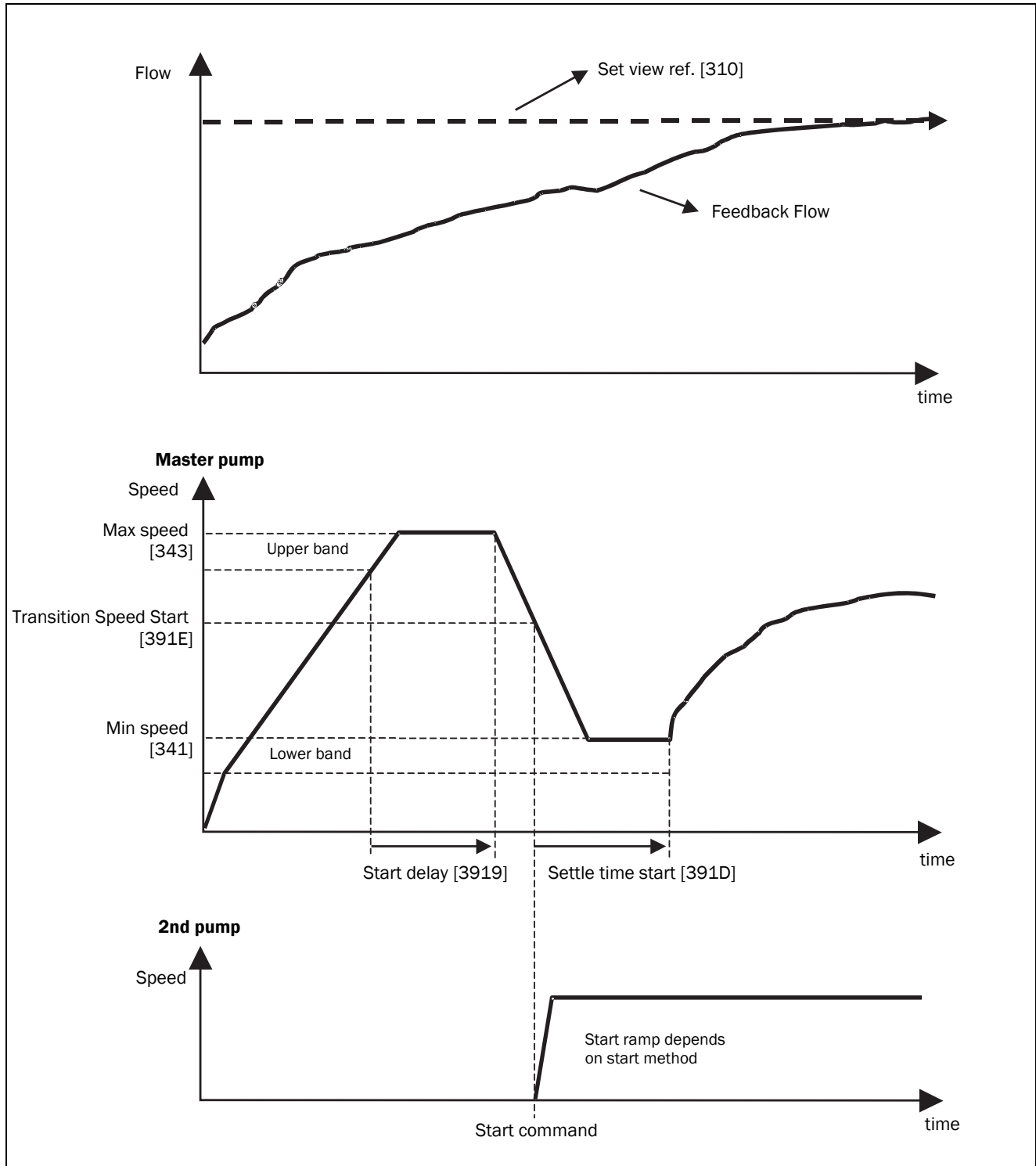

Fig. 93 Time sequence starting an additional pump.

## Stopping an additional pump

This figure shows a possible sequence with all levels and functions involved when an additional pump is stopped by means of the pump control relays. The stopping of the second pump is controlled by one of the relay outputs. The relay in this example stops the pump directly on line. Of course other start/stop equipment like a soft starter could, like a softstarter, be controlled by the relay output.

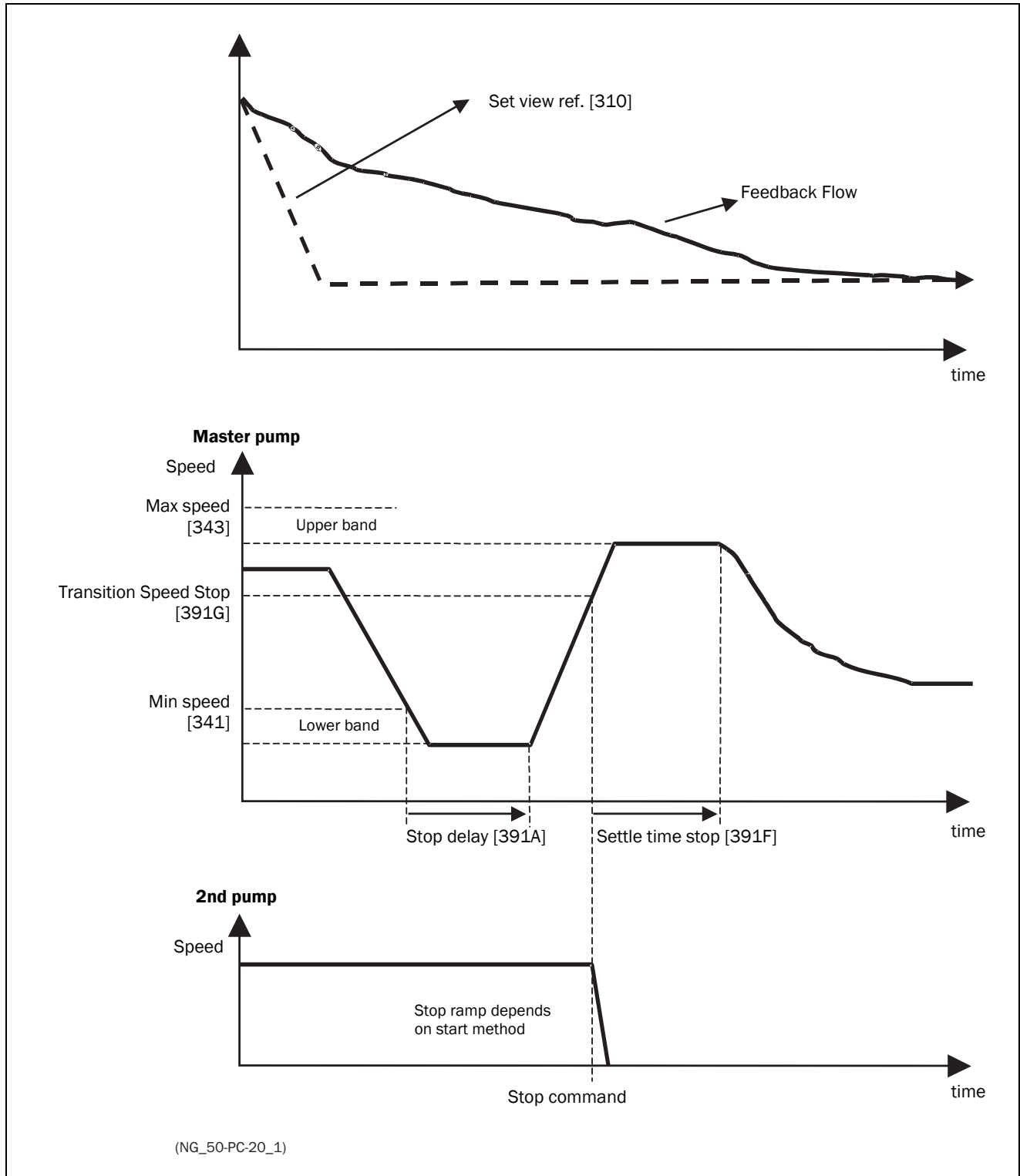

Fig. 94 Time sequence stopping an additional pump.

## 7.7 Pump and fan control [391]

See Chapter 11.3.10 page 154 for more information about this menu.

## 7.8 Pump cleaning [392]

The pumps can get clogged when pumping waste water, that includes various materials. Problems either emerge from gradual buildup of small fibers on the impeller or bigger objects, like rugs, that get stuck in the pump. Often these objects can be cleaned from the pump by reversing it if done in time.

---

**NOTE:** Before turning this feature on, make sure that the installation can handle running the pump in reverse direction. Not all pumps or all configurations can operate in the opposite direction. Please check with the pump manufacturer.

---

Pump cleaning is a function which reverses the motor speed for a short time in order to remove dirt and obstacles in the pump. The pump cleaning function is enabled/disabled by menu [3921].

When triggered, the function does the following:

1. Motor decelerates/accelerates according to the settings in menus [392B4] and [392B3], until speed set in menu [392B2] is reached.
2. Motor runs for [392B1] seconds at this speed.
3. Steps (1) and (2) are repeated two more times according to the settings for phase 2 and 3 in menus [392C] and [392D]. Phases can be skipped by setting the phase time to 0 s.

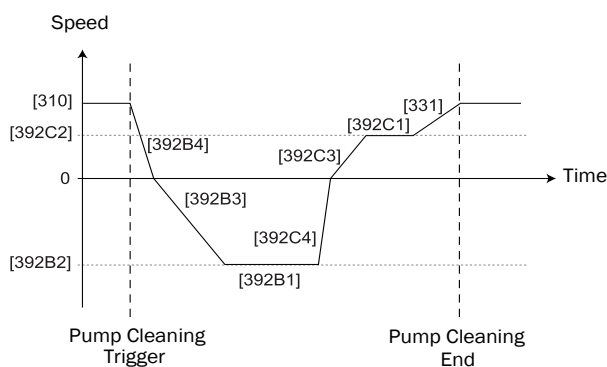

Fig. 95 Example pump cleaning run with two phases (menu Ph3 Time [392D1] set to Off).

Pump cleaning can be triggered by the following sources:

1. Manual trigger by setting menu [392A1] to "On".
2. Digital input configured as "PumpClTrig".
3. At each start by setting menu [392A2] to "On".
4. At the run time interval configured in menu [392A5].
5. Weekly cleaning schedule by configuring the weekly interval in menu [392A6], which weekdays to run in menu [392A7] and the start time in menu [392A8]. Menu [392A9] can be set to the initial start date of the schedule, after which its value is updated to show the date of the next scheduled pump cleaning.
6. Automatic detection by load monitor.

Pump cleaning is blocked by the following sources:

1. When "Pump/Fan Ctl" [3911] is set to "On".
2. Manual block by setting menu [3922] to "Off".
3. Digital input configured as "PumpClBlock".
4. During jog.
5. When drive is in torque mode.

### 7.8.1 Load monitor - automatic detection

The load monitor can be used to automatically detect clogging of the pump to resolve the problem automatically without the need for costly manual maintenance. In addition it is often vital to detect clogging problems early; otherwise pump cleaning by reversing the pump will have little effect.

Pump cleaning is triggered by the load monitor when the load torque is greater than [41B] (normal load) + [392A3] (LoadMonMarg) for [392A4] seconds.

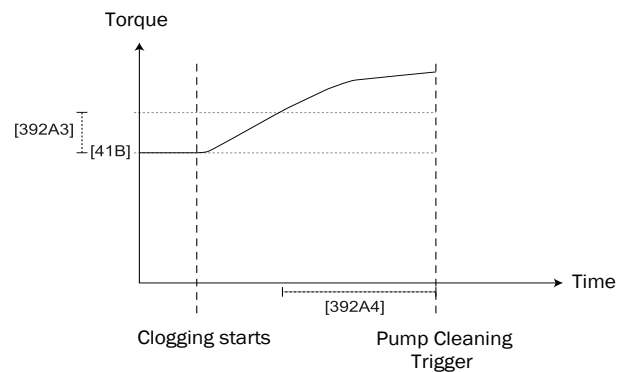

Fig. 96 Pump cleaning triggers on automatic load monitor detection.

If the problem persists after a finished cleaning the cleaning operation may trigger again up to a maximum of [392E] attempts.

The drive signals a trip or warning depending on menu [3921] once the maximum number of cleaning attempts has been reached.

## 7.8.2 Different ways a pump can get clogged

In the case of fibre buildup the initial sign of a partially clogged impeller is slightly lower power usage and a reduced amount of pumped water. Fluctuations in current might be present, emerging from one or more clogged vanes. At this stage the dirt can often be flushed out of the pump by reversing the pump for a short while. If the pump is not cleaned at this stage additional buildup will result in further decreased efficiency. In the final stage the pump accumulates dirt to a point where pumping stops and energy will be consumed in internal friction losses. Generally this requires even more energy than normal operation. At this stage the pump cannot be cleaned by reversing and manual maintenance is required.

Should a rug or other bigger objects get stuck in the pump the load will increase significantly quite swiftly. Such objects are often only stuck for a short period of time and then flushed away without any action taken. Pump cleaning can be avoided for these types of objects by setting an appropriate load monitor trigger delay [392A4].

## 8. EMC and standards

### 8.1 EMC standards

The AC drive complies with the following standards:

EN IEC 61800-3:2018 Adjustable speed electronic power drive systems, part 3, EMC product standards:

Standard: Category C3, for systems of rated supply voltage < 1000 VAC, intended for use in the second environment.

Optional: Category C2 for systems of rated supply voltage < 1.000 V, which is neither a plug in device nor a movable device and, when used in the first environment, is intended to be installed and commissioned only by experienced person with the necessary skills in installing and/or commissioning AC drives including their EMC aspects.

### 8.2 Stop categories and emergency stop

The following information is important if emergency stop circuits are used or needed in the installation where a AC drive is used. EN 60204-1 defines 3 stop categories:

#### Category 0: Uncontrolled STOP:

Stopping by switching off the supply voltage. A mechanical stop must be activated. This STOP may not be implemented with the help of a AC drive or its input/output signals.

#### Category 1: Controlled STOP:

Stopping until the motor has come to rest, after which the mains supply is switched off. This STOP may not be implemented with the help of a AC drive or its input/output signals.

#### Category 2: Controlled STOP:

Stopping while the supply voltage is still present. This STOP can be implemented with each of the AC drives STOP command.



#### WARNING!

EN 60204-1 specifies that every machine must be provided with a category 0 stop. If the application prevents this from being

implemented, this must be explicitly stated. Furthermore, every machine must be provided with an Emergency Stop function. This emergency stop must ensure that the voltage at the machine contacts, which could be dangerous, is removed as quickly as possible, without resulting in any other danger. In such an Emergency Stop situation, a category 0 or 1 stop may be used. The choice will be decided on the basis of the possible risks to the machine.

---

NOTE: With the Safe Torque Off (STO) option, a stop according to EN 61508 parts 1-3:2010 SIL 2, and EN ISO 13849-1:2023 Category 4 and PL e, can be achieved. Safety-related parameters are specified in the instruction manual for Safe Torque Off (STO), manual no. 01-7513-11, Chapter "Technical Data". See also Section 13.13 page 229.

---



## 9. Communication

The AC drive provides possibility for different types of communication:

- Galvanic isolated Modbus RTU via RS-485 interface on X1 terminal on control board. See “4. Control Connections” on page 49.
- Modbus RTU via RS-232 interface behind the control panel (not galvanic isolated).
- Wireless interfaces provided by the connected control panel.
  - Control panel with WiFi (optional) provides Modbus/TCP.
  - Control panel with BLE (optional) enables connectivity with mobile application.
- Fieldbuses as Profibus DP, DeviceNET and CANopen.
- Industrial Ethernet as Modbus/TCP, Profinet IO, EtherCAT, and EtherNet/IP.

For available communication options see “13. Options” on page 225.

### 9.1 Modbus RTU

Preferably use the isolated RS-485 interface for serial communication. This port is galvanically isolated. The protocol used for data exchange is based on the Modbus RTU protocol, originally developed by Modicon.

The AC drive acts as a slave with selectable address in a master-slave configuration. The communication is half-duplex. It has a standard non return zero (NRZ) format.

The baud rate of the RS-485 interface is adjustable between 2400 to 115200.

The character frame format (always 11 bits) has:

- one start bit
- eight data bits
- two stop bits
- no parity

The AC drive has also an asynchronous serial communication interface, RS-232, behind the control panel.

Please note that this port is not galvanically isolated.

It is possible to temporarily connect a personal computer with for example the software EmoSoftCom (programming and monitoring software) to the RS-232 connector on the control panel. This can be useful when copying parameters between AC drives etc. For permanent connection of a personal computer you have to use one of the communication option boards.

---

**NOTE: This RS-232 port is not isolated.**

---



---

**NOTE:** Communication Fault detection can cause the drive to give a warning or trip when the Control Panel is removed (see menus [2645] and [2646]), or when Control Panel port communication is faulty (see menus [2647] and [2648]).

---



#### WARNING!

Correct and safe use of a RS-232 connection depends on the ground pins of both ports being the same potential.

Problems can occur when connecting two ports of e.g. machinery and computers where both ground pins are not the same potential. This may cause hazardous ground loops that can destroy the RS-232 ports.

The RS-232 connection behind the control panel is not galvanically isolated.

Note that the control panel RS-232 connection can safely be used in combination with commercial available isolated USB to RS-232 converters.

---

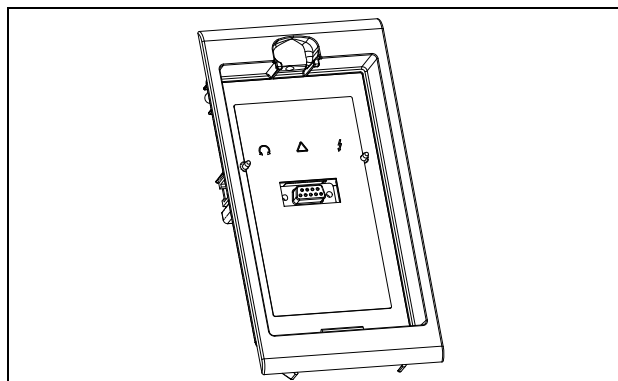

Fig. 97 RS-232 connector behind the control panel

### 9.2 Parameter sets

Communication information for the different parameter sets.

The different parameter sets in the AC drive have the following DeviceNet instance numbers, Profibus slot/index numbers, Profinet IO index and EtherCAT index numbers:

Param. set	Modbus/ DeviceNet Instance number	Profibus Slot/Index	Profinet IO index	EtherCAT and CANopen index (hex)
A	43001–43899	168/160 to 172/38	19385 - 20283	4bb9 - 4f3b
B	44001–44899	172/140 to 176/18	20385 - 21283	4fa1 - 5323
C	45001–45899	176/120 to 179/253	21385 - 22283	5389 - 5706
D	46001–46899	180/100 to 183/233	22385 - 23283	5771 - 5af3

Parameter set A contains parameters 43001 to 43899. The parameter sets B, C and D contains the same type of information. For example parameter 43123 in parameter set A contain the same type of information as 44123 in parameter set B.

## 9.3 Motor data

Communication information for the different motors.

Motor	Modbus/ DeviceNet Instance number	Profibus Slot/ Index	Profinet IO index	EtherCAT and CANopen index (hex)
M1	43041- 43048	168/200 to 168/207	19425 - 19432	4be1 - 4be8
M2	44041- 44048	172/180 to 174/187	20425 - 20432	4fc9 - 4fd0
M3	45041- 45048	176/160 to 176/167	21425 - 21432	53b1 - 53b8
M4	46041- 46048	180/140 to 180/147	22425 - 22432	5799 - 57a0

M1 contains parameters 43041 to 43048. The M2, M3, and M4 contains the same type of information. For example parameter 43043 in motor M1 contain the same type of information as 44043 in M2.

## 9.4 Start and stop commands

Set start and stop commands via serial communication.

Modbus/DeviceNet Instance number	Function
42901	Reset
42902	Run, active together with either RunR or RunL to perform start.
42903	RunR
42904	RunL

**Note!** Bipolar reference mode is activated if both RunR and RunL is active.

## 9.5 Reference signal

When menu “Reference Control [214]” is set to “Com” the following parameter data should be used:

Default	0
Range	-16384 to 16384
Corresponding to	-100% to 100% ref

Communication information

Modbus /DeviceNet Instance number	42905
Profibus slot /Index	168/64
EtherCAT index (hex)	4b59
Profinet IO index	19289
Fieldbus format	Int
Modbus format	Int

### 9.5.1 Process value

It is also possible to send the Process value feedback signal over a bus (e.g. from a process or temperature sensor) for use with PID Process controller [380].

Set menu “Process Source [321]” to F(Bus). Use following parameter data for the process value:

Default	0
Range	-16384 to 16384
Corresponding to	-100% to 100% process value

Communication information

Modbus /DeviceNet Instance number	42906
Profibus slot /Index	168/65
EtherCAT index (hex)	4b5a
Profinet IO index	19290
Fieldbus format	Int
Modbus format	Int

### Example:

(See Emotron Fielbus manual for detailed information)

We would like to control the AC drive over a bus system using the first two bytes of the Basic Control Message by setting menu “[2661] FB Signal 1” to 49972. Further, we also want to transmit a 16 bit signed reference and a 16 bit process value. This is done by setting menu “[2662] FB Signal 2” to 42905 and menu “[2663] FB Signal 3” to 42906.

**NOTE!** It is possible to view the transmitted process value in control panel menu Operation [710]. The presented value is depending on settings in menus “Process Min [324]” and “Process Max [325]”.

## 9.6 Description of the EInt formats

Eint is only used with Modbus-RTU and Modbus-TCP protocols.

A parameter with Eint format can be represented in two different formats (F). Either as a 15 bit unsigned integer format (F= 0) or a Emotron floating point format (F=1). The most significant bit (B15) indicates the format used. See detailed description below.

All parameters written to a register may be rounded to the number of significant digits used in the internal system.

The matrix below describes the contents of the 16-bit word for the two different EInt formats:

B15	B14	B13	B12	B11	B10	B9	B8	B7	B6	B5	B4	B3	B2	B1	B0
F=1	e3	e2	e1	e0	m10	m9	m8	m7	m6	m5	m4	m3	m2	m1	m0
F=0	B14	B13	B12	B11	B10	B9	B8	B7	B6	B5	B4	B3	B2	B1	B0

If the format bit (B15) is 0, then all bits may be treated as a standard unsigned integer (UInt)

If the format bit is 1, then is the number interpreted as this:

Value = M \* 10<sup>E</sup>, where M=m10..m0 represents a two- complement signed mantissa and E= e3..e0 represents a two- complement signed exponent.

---

**NOTE: Parameters with EInt format may return values both as 15 bit unsigned int (F=0) or in Emotron floating point (F=1).**

---

### Example, resolution

If you write the value 1004 to a register and this register has 3 significant digits, it will be stored as 1000.

In the Emotron floating point format (F=1), one 16-bit word is used to represent large (or very small numbers) with 3 significant digits.

If data is read or written as a fixed point (i.e. no decimals) number between 0-32767, the 15 bit Unsigned integer format (F=0) may be used.

### Detailed description of Emotron floating point format

e3-e0 4-bit signed exponent. Gives a value range:

-8..+7 (binary 1000 .. 0111)

m10-m0 11-bit signed mantissa.Gives a value range:

-1024..+1023 (binary 10000000000..01111111111)

A signed number should be represented as a two complement binary number, like below:

Value Binary

-8 1000

-7 1001

..

-2 1110

-1 1111

0 0000

1 0001

2 0010

..

6 0110

7 0111

The value represented by the Emotron floating point format is m·10<sup>e</sup>.

To convert a value from the Emotron floating point format to a floating point value, use the formula above.

To convert a floating point value to the Emotron floating point format, see the C-code example below.

### Example, floating point format

The number 1.23 would be represented by this in Emotron floating point format,

```
F EEEE MMMMMMMMMMMM
1 1110 00001111011
F=1 -> floating point format used
E=-2
M=123
```

The value is then  $123 \times 10^{-2} = 1.23$

### Example 15bit unsigned int format

The value 72.0 can be represented as the fixed point number 72. It is within the range 0-32767, which means that the 15-bit fixed point format may be used.

The value will then be represented as:

B15	B14	B13	B12	B11	B10	B9	B8	B7	B6	B5	B4	B3	B2	B1	B0
0	0	0	0	0	0	0	0	0	1	0	0	1	0	0	0

Where bit 15 indicates that we are using the fixed point format (F=0).

## Programming example:

```
typedef struct
{
    int m:11; // mantissa, -1024..1023
    int e: 4; // exponent -8..7
    unsigned int f: 1; // format, 1->special emoint format
}    eint16;
//-----
unsigned short int float_to_eint16(float value)
{
    eint16 etmp;
    int dec=0;

    while (floor(value) != value && dec<16)
    {
        dec++; value*=10;
    }
    if (value>=0 && value<=32767 && dec==0)
        *(short int *)&etmp=(short int)value;
    else if (value>=-1000 && value<0 && dec==0)
    {
        etmp.e=0;
        etmp.f=1;
        etmp.m=(short int)value;
    }
    else
    {
        etmp.m=0;
        etmp.f=1;
        etmp.e=-dec;
        if (value>=0)
            etmp.m=1; // Set sign
        else
            etmp.m=-1; // Set sign
        value=fabs(value);
        while (value>1000)
        {
            etmp.e++; // increase exponent
            value=value/10;
        }
        value+=0.5; // round
        etmp.m=etmp.m*value; // make signed
    }
    return (*(unsigned short int *)&etmp);
}
//-----
float eint16_to_float(unsigned short int value)
{
    float f;
    eint16 evalue;

    evalue=*(eint16 *)&value;
    if (evalue.f)
    {
        if (evalue.e>=0)
            f=(int)evalue.m*pow10(evalue.e);
        else
            f=(int)evalue.m/pow10(abs(evalue.e));
    }
    else
        f=value;

    return f;
}
//-----
```

## 9.7 32-bit read/write support

Support for reading and writing internally used 32-bit parameter values (if available). This makes it possible to read/write EINT values with the same number of digits as used by the control panel.

You can configure up to 10 Modbus numbers in Modbus registers 42570-42579. The corresponding values are accessible in Modbus registers 42580-42599. Even numbered registers hold the 16 MSBs and odd numbered registers hold the 16 LSBs. Read/write the MSBs before the LSBs. Reading the MSBs copies all 32 bits from the actual parameter. Writing the LSBs copies all 32 bits to the actual parameter.

Example: Reading 32-bit values from the energy registers 31034 (Wh) and 31035 (GWh) makes it possible to read out exact Wh values also for high energy values, e.g. 123456789 Wh. The standard EINT format provides three significant digits, e.g. 1.23e8 Wh.



# 10. Operation via the Control Panel

This chapter describes how to use the control panel. The AC drive can be delivered with a control panel or a blank panel.

## 10.1 General

The control panel displays the status of the AC drive and is used to set all the parameters. It is also possible to control the motor directly from the control panel. The control panel can be built-in or located externally via serial communication. The AC drive can be ordered without the control panel. Instead of the control panel there will be a blank panel.

---

**NOTE:** The AC drive can run without the control panel being connected. However the settings must be such that all control signals are set for external use.

---

## 10.2 Control panel with 4-line display

This control panel with 4-line display is equipped with real time clock function. This means that actual date and time will be shown at e.g. a trip condition.

There is also an optional Control panel with Bluetooth communication available. See Chapter 13. Options on page 225 for more information.

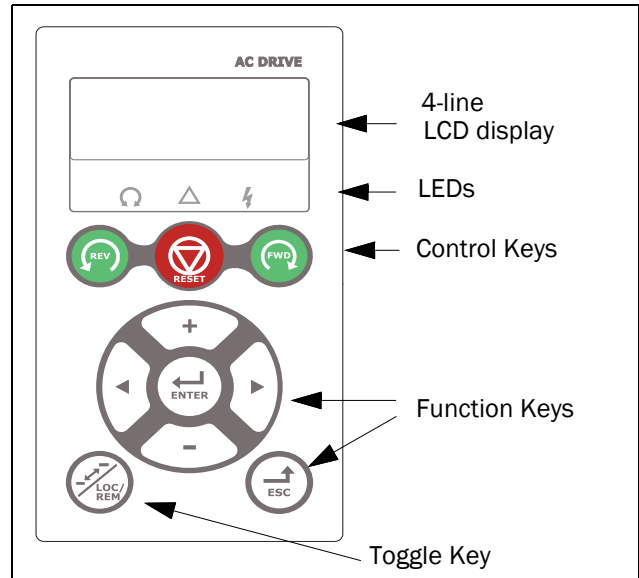

Fig. 98 Control panel with 4-line display, LEDs and Keys..

### 10.2.1 The display

The display is back lit and consists of 4 rows, each with space for 20 characters. The display is divided into following areas. The different areas in the display are described below:

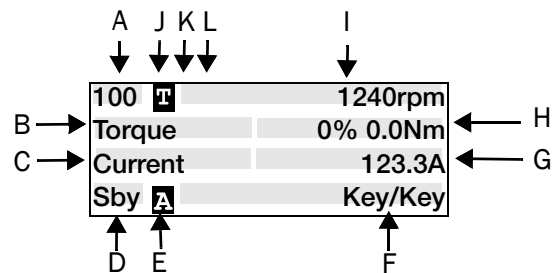

Fig. 99 The display.

Area A: Shows the actual menu number (3 or 4 digits).

Area B: Menu name or heading (Except in menus 100+ mode), 8 characters field.

Area C: Edit Cursor if editing or heading in menu [100], 8 characters field.

Area D \*: Shows the status of the AC drive (3 digits). The following status indications are possible:

Table 29

Digits	Description	Bit*
Stp	Motor is stopped	0
Run	Motor runs	1
Acc	Acceleration	2
Dec	Deceleration	3
Trp	Tripped	4
STO	Operating Safe Torque Off, flashing when activated	5
VL	Operating at voltage limit	6
SL	Operating at speed limit	7
CL	Operating at current limit	8
TL	Operating at torque limit	9
OT	Operating at temperature limit	10
I <sup>2</sup> t	Active I <sup>2</sup> t protection	11
LV	Operating at low voltage	12
Sby	Operating from Standby power supply	13
LCL	Operating with low cooling liquid level	14
Slp	Sleep mode	15
SPS	Spin start active	16
PCL	Pump cleaning active	17
M/S	Slave inverter in a master-slave configuration	18
Opt	Option specific indication	19
CRI	Crane option communication warning	20
LVS	Low voltage override sleep mode	21

\*) The status shown in Area D on the control panel can be read via a fieldbus or serial communication, e.g. using Modbus address no 30053, see [72B] in chapter 15 Menu list.

It is also possible to read all status indications, not just the highest prioritized one, via a fieldbus or serial communication, e.g. using Modbus address no 30180 and 30182. This information is also shown in EmoSoftCom PC-tool (optional) see menu "Area D stat [72B]". Area I:Active Motor set M1 - M4 (Set in menu [212]).

Area E: Shows active parameter set: **A**, **B**, **C**, or **D** [241].

Area F: Active control source.

Area G: Parameter value, shows the setting or selection in the active menu, 12 characters field.

This area is empty at the 1st level and 2nd level menu. This area also shows warnings and alarm messages. In some situations this area could indicate "+++" or "---" see further information in the Instruction manual.

Area H: Signal values shown in menu [100], 12 characters field.

Area I: Preferred read-out value (chosen in menu [110])

Area J: Shows if the menu is in the toggle loop and/or the AC drive is set for Local operation.

**T** = in Toggle loop

**L T** = in Local operation and Toggle loop

**L** = Local operation

Area K: First row character 7 show an inverted **B**  in case a Bluetooth connection is active.

Area L: First row character 8 show a WiFi symbol  in case a WiFi connection is active.

---

**NOTE:**

In area B and area C only 8 characters are available, this means that some texts will be shortened.

---

## 10.2.2 Menu [100] Start Window

This menu is displayed at every power-up. During operation, the menu [100] will automatically be displayed when the keyboard is not operated for 5 minutes.

Menu “[100] Start Window” displays the settings made in menu “[110], 1st line”, “[120], 2nd line” and “[130], 3rd line”.

100	T	1240rpm	← First line - set in Menu [110].
Torque		0% 0.0Nm	← Second line - set in Menu [120]
Current		123.3A	← Third line - set in Menu [130]
Sby	A	Key/Key	

### Extended signal monitoring

If you hold the  key when in menu [100] following window will appear, as long as the key is pressed.

Here First, Second and Third line are shown as selected in menu [100].

Then additional information will be displayed, selected in the menus [140], [150] and [160] according to below.

100	T	0rpm	← First line - set in Menu [110].
3.9V		0.0A	← Second line - set in Menu [120].
0.0°C		0.0Hz	← Third line - set in Menu [130].
Sby	A	A/Rem/Rem/--	← Fourth line - set in Menu [140]
			← Fifth line - set in Menu[150].
			← Sixth line - set in Menu[160]

Use menu “[170] View mode” to select active type of menu [100] presentation, select if “Normal 100” or “Always 100+” Extended signal monitoring” shall be shown at power-up. A third choice is menu “Normal100wo” = menu [100] without explaining text at second and third line.

## 10.2.3 Editing mode

All other menus (read and read/write menus) are used in following way.

221	T	1240rpm	← Shows Menu number to the left and to the right signal selected in menu [110].
Motor Volts			← Shows menu name to the left
M1		380V	← Shows menu value to the right and if it is a Motor parameter active Motor set (M1 in this case) is displayed to the left.
Run	A	Key/Key	← Shows Drive status/Parameter set and Control source as in menu [100]

During editing, preferred view will not be displayed and the cursor will appear blinking to the left. See also below.

211	T		← Preferred view is not shown during editing.
Language		English	
Run	A	Loc/Loc	←  = blinking during editing

## 10.2.4 Fault logger

As real-time clock is available, line 2 will show trip/warning message and line three will show date and time when the trip condition occurred.

810	1240rpm
Ext trip	
2017-01-25	12:34.40
Run	Rem/Rem

## 10.2.5 Real Time clock

In this 4-line Control panel there is a built in Real time clock. This means that actual date and time will be shown at e.g. a trip condition. There is a built-in capacitor to be able to keep the clock running if the power disappears.

In case of loss of power, the backup time for the Real time clock function is at least 60 days.

Actual date and time will be set from factory. However as the backup time is only around 60 days, it is recommended to set the Date and time during commissioning. Date and time is shown and can be set in following menus.

### Clock [930]

This menu group displays actual time and date, read only. Time and date are factory set to CET (Central European mean time). Adjust if required in following sub-menus.

930	1240rpm
Clock	
2017-01-23	12:34.40
Run	Key/Key

### Time [931]

Actual time, displayed as HH:MM:SS. Adjustable setting.

931	1240rpm
Time	
	12:34.40
Run	Key/Key

Unit	hh:mm:ss (hours: minutes: seconds)
------	------------------------------------

### Date [932]

Actual date, displayed as YYYY-MM-DD. Adjustable setting.

932	1240rpm
Date	
	2017-01-23
Run	Key/Key

Unit:	YYYY-MM-DD (year-month-day)
-------	-----------------------------

### Weekday [933]

Display of actual weekday, read only.

933	1240rpm
Weekday	
	Monday
Run	Key/Key

## 10.2.6 LED indicators

The symbols on the control panel have the following functions:

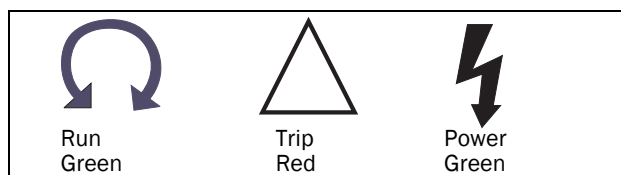

Fig. 100 LED indications.

Table 30 LED indication

Symbol	Function		
	ON	FLASHING	OFF
<b>POWER (green)</b>	Power on	-----	Power off
<b>TRIP (red)</b>	AC drive tripped	Warning/Limit	No warning or trip
<b>RUN (green)</b>	Motor shaft rotates	Motor speed increase/decrease	Motor stopped

## 10.2.7 Control keys

The control keys are used to give the Run, Stop or Reset commands directly. As default these keys are disabled, set for remote control. Activate the control keys by selecting Keyboard in the menus "Ref Control [214]", "Run/Stop Control [215]" and "Reset Ctrl [216]".

If the Enable function is programmed on one of the digital inputs, this input must be active to allow Run/Stop commands from the control panel.

Table 31 Control keys

	RUN L:	gives a start with left rotation
	STOP/RESET:	stops the motor or resets the AC drive after a trip
	RUN R:	gives a start with right rotation

**NOTE:** It is not possible to simultaneously activate the Run/Stop commands from the keyboard and remotely from the terminal strip (terminals 1-22). Exception is the JOG-function which can give start command, see Jog Speed [348] on page 145.

## 10.2.8 The Toggle and Loc/Rem Key



This key has two functions: Toggle and switching between Loc/Rem function.

Press one second to use the toggle function

Press and hold the toggle key for more than five seconds to switch between Local and Remote function, depending on the settings in [2171] and [2172].

When editing values, the toggle key can be used to change the sign of the value, see Section 10.5, page 97.

### Toggle function

Using the toggle function makes it possible to easily step through selected menus in a loop. The toggle loop can contain a maximum of ten menus. As default the toggle loop contains the menus needed for Quick Setup. You can use the toggle loop to create a quick-menu for the parameters that are most importance to your specific application.

**NOTE:** Do not keep the Toggle key pressed for more than five seconds without pressing either the +, - or Esc key, as this may activate the Loc/Rem function of this key instead. See menu [217].

### Add a menu to the toggle loop

1. Go to the menu you want to add to the loop.
2. Press the Toggle key and keep it pressed while pressing the + key.

### Delete a menu from the toggle loop

1. Go to the menu you want to delete using the toggle key.
2. Press the Toggle key and keep it pressed while pressing the - key.

### Delete all menus from the toggle loop

1. Press the Toggle key and keep it pressed while pressing the Esc key.
2. Confirm with Enter.

### Default toggle loop

Fig. 101 shows the default toggle loop. This loop contains the necessary menus that need to be set before starting. Press Toggle to enter menu [211] then use the Next key to enter the sub menus [212] to [21A] and enter the parameters. When you press the Toggle key again, menu [221] is displayed.

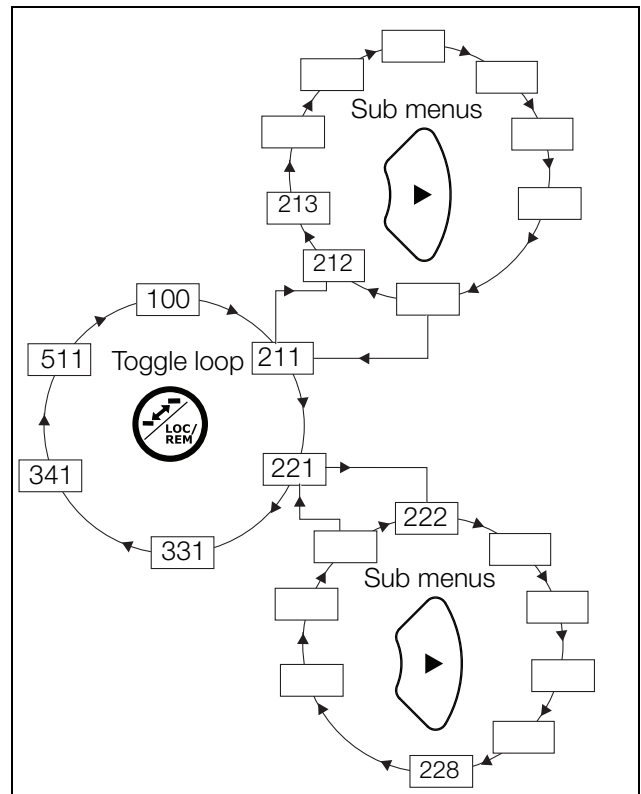



Fig. 101 Toggle loop example.

### Indication of menus in toggle loop

Menus included in the toggle loop are indicated with a  in area B in the display.

### Loc/Rem function

The Loc/Rem function of this key is disabled as default. Enable the function in menu [2171] and/or [2172].

With the function Loc/Rem you can change between local and remote control of the AC drive from the control panel. The function Loc/Rem can also be changed via the DigIn, see menu "Digital inputs [520]".

### Change control mode

1. Press the Loc/Rem key for five seconds, until Local? or Remote? is displayed.
2. Confirm with Enter.
3. Cancel with Esc.

### Local mode

Local mode is used for temporary operation. When switched to LOCAL operation, the AC drive is controlled via the defined Local operation mode, i.e. [2171] and [2172]. The actual status of the AC drive will not change, e.g. Run/Stop conditions and the actual speed will remain exactly the same. When the AC drive is set to Local operation, the display will show  in area B in the display.

## Remote mode

When the AC drive is switched to REMOTE operation, the AC drive will be controlled according to selected control methods in the menu's "Reference Control [214]", "Run/Stop Control [215]" and "Reset Control [216]".

To monitor the actual Local or Remote status of the AC drive control, a "Loc/Rem" signal is available on the Digital Outputs or Relays. When the AC drive is set to Local, the signal on the DigOut or Relay will be active/high, in Remote the signal will be inactive/low. See menu "Digital Outputs [540]" and "Relays [550]".

## 10.2.9 Function keys

The function keys operate the menus and are also used for programming and read-outs of all the menu settings.

Table 32 Function keys

	ENTER key:	<ul style="list-style-type: none"> <li>- step to a lower menu level</li> <li>- confirm a changed setting</li> </ul>
	ESCAPE key:	<ul style="list-style-type: none"> <li>- step to a higher menu level</li> <li>- ignore a changed setting, without confirming</li> </ul>
	PREVIOUS key:	<ul style="list-style-type: none"> <li>- step to a previous menu within the same level</li> <li>- go to more significant digit in edit mode</li> </ul>
	NEXT key:	<ul style="list-style-type: none"> <li>- step to a next menu within the same level</li> <li>- go to less significant digit in edit mode</li> </ul>
	- key:	<ul style="list-style-type: none"> <li>- decrease a value</li> <li>- change a selection</li> </ul>
	+ key:	<ul style="list-style-type: none"> <li>- increase a value</li> <li>- change a selection</li> </ul>
	TOGGLE and LOC/REM key:	<ul style="list-style-type: none"> <li>- Toggle between menus in the toggle loop</li> <li>- Switching between local and remote control</li> <li>- Change the sign of a value</li> </ul>

## 10.3 The menu structure

The menu structure consists of 4 levels:

Main Menu 1st level	The first character in the menu number.
2nd level	The second character in the menu number.
3rd level	The third character in the menu number.
4th level	The fourth character in the menu number.

This structure is consequently independent of the number of menus per level.

For instance, a menu can have one selectable menu (Set/View Reference Value [310]), or it can have 17 selectable menus (menu Speeds [340]).

**NOTE: If there are more than 10 menus within one level, the numbering continues in alphabetic order.**

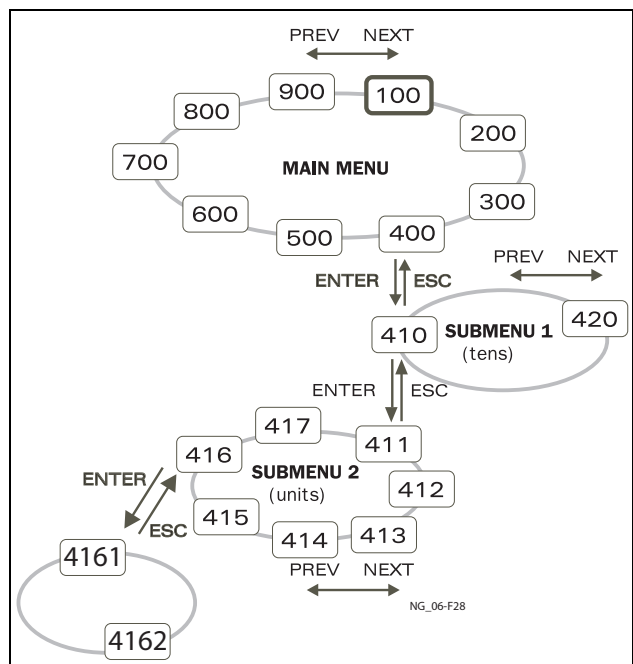

Fig. 102 Menu structure.

### 10.3.1 The main menu

This section gives you a short description of the functions in the Main Menu.

#### 100 Start Window

Displayed at power-up. It displays the actual process value as default. Programmable for many other read-outs.

#### 200 Main Setup

Main settings to get the AC drive operable. The motor data settings are the most important. Also option utility and settings.

#### 300 Process and Application Parameters

Settings more relevant to the application such as Reference Speed, torque limitations, PID control settings, etc.

#### 400 Load Monitor and Process Protection

The monitor function enables the AC drive to be used as a load monitor to protect machines and processes against mechanical overload and underload.

#### 500 Inputs/Outputs and Virtual Connections

All settings for inputs and outputs are entered here.

#### 600 Logical Functions and Timers

All settings for conditional signals are entered here.

#### 700 View Operation and Status

Viewing all the operational data like frequency, load, power, current, etc.

#### 800 View Trip Log

Viewing the last 10 trips in the trip memory.

#### 900 System data

Electronic type label for viewing the software version and AC drive type.

## 10.4 Programming during operation

Most of the parameters can be changed during operation without stopping the AC drive. Parameters that can not be changed are marked with a lock symbol in the display.

---

**NOTE:** If you try to change a function during operation that only can be changed when the motor is stopped, the message "Stop First" is displayed.

---

## 10.5 Editing values in a menu

Most values in the third row in a menu can be changed in two different ways. Enumerated values like the baud rate can only be changed with alternative 1.

2621		0rpm
Baudrate		
		38400
Stp		Key/Key

### Alternative 1

When you press the + or - keys to change a value, the cursor is flashing to the left in the display and the value is increased or decreased when you press the appropriate key. If you keep the + or - keys pressed, the value will increase or decrease continuously. When you keep the key pressed the change speed will increase. The Toggle key is used to change the sign of the entered value. The sign of the value will also change when zero is passed. Press Enter to confirm the value.

331		0rpm
Acc Time		
		10.0s
Stp		Key/Key

### Alternative 2

Press the + or - key to enter edit mode. Then press the Prev or Next key to move the cursor to the right most position of the value that should be changed. The cursor will make the selected character flash. Move the cursor using the Prev or Next keys. When you press the + or - keys, the character at the cursor position will increase or decrease. This alternative is suitable when you want to make large changes, i.e. from 2 s to 400 s.

To change the sign of the value, press the toggle key. This makes it possible to enter negative values (Only valid for certain parameters).

Example: When you press Next the 4 will flash.

331		0rpm
Acc Time		
		10.0s ← Flashing
Stp		Key/Key

Press Enter to save the setting and Esc to leave the edit mode.





## 10.6 Copy current parameter to all sets

When a parameter is displayed, press the Enter key for 5 seconds. Now the text To all sets? is displayed. Press Enter to copy the setting for current parameter to all sets.

## 10.7 Programming example

This example shows how to program a change of the Acc. Time set from 10.0 s to 12.0 s.

The flashing cursor indicates that a change has taken place but is not saved yet. If at this moment, the power fails, the change will not be saved. Use the ESC, Prev, Next or the Toggle keys to proceed and to go to other menus.

<pre> 100 T 0rpm Torque 0% 0.0Nm Current 0.0A Stp A Key/Key           </pre>	<p>Menu 100 appears after power-up.</p>
	<p>Press "Next" key for menu [200].</p>
<pre> 200 T 0rpm Main setup Stp A Key/Key           </pre>	
	<p>Press "Next" key for menu [300].</p>
<pre> 300 T 0rpm Process Stp A Key/Key           </pre>	
	<p>Press "Enter" key for menu [310].</p>
<pre> 310 T 0rpm Set/View ref 0rpm Stp A Key/Key           </pre>	
	<p>Press "Next" key twice for menu [330].</p>



<pre> 330 T 0rpm Start/Stop Stp A Key/Key           </pre>	
	<p>Press "Enter" for menu [331].</p>
<pre> 331 T 0rpm Acc Time 10.0s Stp A Key/Key           </pre>	
	<p>Press "+" key</p>
<pre> 331 T 0rpm Acc Time 12.0s Stp A Key/Key           </pre>	<p>Keep "+" key pressed until desired value has been reached.</p>
	<p>Save the changed value by pressing "Enter" key.</p>
<pre> 331 T 0rpm Acc Time 12.0s Stp A Key/Key           </pre>	

Fig. 103 Programming example

# 11. Functional description

This chapter describes the menus and parameters in the software. See Chapter 10.2 Control panel with 4-line display, page 91 in chapter Operation for detailed information about the Control panel.

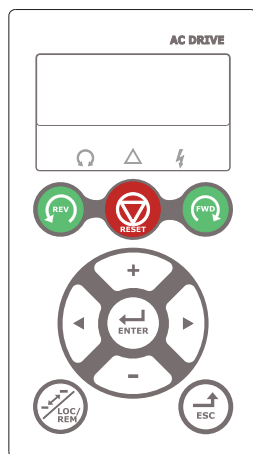



Fig. 104 LCD display

## 11.1 Menus

Following chapters describes the menus and parameters in the software. You will find a short description of each function and information about default values, ranges, etc. There are also tables containing communication information. You will find the parameter number for all available fieldbus options as well as the enumeration for the data.

On our home page in the download area, you could find a "Communication information" list and a list to note "Parameter set" information.

---

**NOTE:** Functions marked with the sign  cannot be changed during Run Mode.

---

### 11.1.1 Description of menu table layout

Following two kinds of tables are used in this chapter.

<b>332</b> ②	 ①	<b>Dec Time</b> ③
Default:		④
⑤	⑥	⑦

<b>222</b> ②	 ①	<b>Motor Freq</b> ③
Default:		50 Hz ④
Range:		20.0 - 300.0 Hz
Resolution		⑦

1. Parameter cannot be changed during operation.
2. Parameter only for viewing.
3. Menu information as displayed on control panel. For explanation of display text and symbols, see Chapter 10. Operation via the Control Panel, page 91.
4. Factory setting of parameter (also showed on display).
5. Available settings for the menu, listed selections.
6. Communication integer value for the selection. For use with communication bus interface (only if selection type parameters).
7. Description of selection alternative, setting or range (min - max value).

## 11.1.2 Resolution of settings

The resolution for all range settings described in this chapter is 3 significant digits. Exceptions are speed values which are presented with 4 significant digits. Table 33 shows the resolutions for 3 significant digits.

Table 33

3 Digit	Resolution
0.01-9.99	0.01
10.0-99.9	0.1
100-999	1
1000-9990	10
10000-99900	100

## 11.1.3 1st Line [110]

Sets the content of the first line in the menu “[100] Start Window”.

110		1st Line	
Default:		Process Val	
Dependent on menu			
Process Val	0	Process value	
Speed	1	Speed	
Torque	2	Torque	
Process Ref	3	Process reference	
Shaft Power	4	Shaft power	
El Power	5	Electrical power	
Current	6	Current	
Output volt	7	Output voltage	
Frequency	8	Frequency	
DC Voltage	9	DC voltage	
IGBT Temp	10	IGBT temperature	
Motor Temp *	11	Motor temperature	
VSD Status	12	AC drive status	
Run Time	13	Run Time	
Energy	14	Energy	
Mains Time	15	Mains time	
Enc Speed **	16	Encoder speed	
Unit Name	17	Unit name	
Time	18	Time	
Date	19	Date	

\* The “Motor temp” is only visible if you have the option PTC/PT100 card installed and a PT100 input is selected in menu[236].

\*\* Can only be selected if Encoder option board is installed.

## 2nd Line [120]

Sets the content of the second line in the menu “[100] Start Window”. Same selection as in menu [110].

120		2nd Line	
Default:		Torque	

## 3rd Line [130]

Sets the content of the third line in the menu “[100] Start Window”. Same selection as in menu [110].

130		3rd Line	
Default:		Frequency	

## 4th Line [140]

Sets the content of the fourth line in the menu “[100] Start Window”. Same selection as in menu [110].

140		4th Line	
Default:		VSD Status	

## 5th Line [150]

Sets the content of the fifth line in the menu “[100] Start Window”. Same selection as in menu [110].

150		5th Line	
Default:		DC Voltage	

## 6th Line [160]

Sets the content of the sixth line in the menu “[100] Start Window”. Same selection as in menu [110].

160		6th Line	
Default:		IGBT Temp	

## View mode [170]

Select how menu [100] shall be displayed.

170		View mode	
Default:		Normal 100	
Normal 100		Preferred view as set in menu 110, 120, 130	
Always 100+		Extended signal monitoring as set in menus 110 - 160	
Normal 100wo		As Normal 100 without text at second and third lines.	

## 11.2 Main Setup [200]

The Main Setup menu contains the most important settings to get the AC drive operational and set up for the application. It includes different sub menus concerning the control of the unit, motor data and protection, utilities and automatic resetting of faults. This menu will instantaneously be adapted to build in options and show the required settings.

### 11.2.1 Operation

Selections concerning the used motor, AC drive mode, control signals and serial communication are described in this submenu and is used to set the AC drive up for the application.

### Language [211]

Select the language used on the LC Display. Once the language is set, this selection will not be affected by the Load Default command.

211 Language		
Default:		English
English	0	English selected
Svenska	1	Swedish selected
Nederlands	2	Dutch selected
Deutsch	3	German selected
Français	4	French selected
Español	5	Spanish selected
Русский	6	Russian selected
Italiano	7	Italian selected
Česky	8	Czech selected
Turkish	9	Turkish selected
Polski	11	Polish selected

### Select Motor [212]

This menu is used if you have more than one motor in your application. Select the motor to define. It is possible to define up to four different motors, M1 to M4, in the AC drive. For parameter set handling including Motor sets M1 - M4 see Chapter 11.2.4 Parameter Set Handling [240], page 116.

212 Select Motor		
Default:		M1
M1	0	Motor Data is connected to selected motor.
M2	1	
M3	2	
M4	3	

### Drive Mode [213]

This menu is used to set the control mode for the motor. Settings for the reference signals and read-outs is made in menu "Process source, [321]".

- Speed Mode offers an accurate control of the motor speed independently of the load. The Speed mode also increases the accuracy of the different analogue output signals that are related to the motor speed. Speed mode can also be used if several motors of same type and size are connected in parallel. Requires all motors to be mechanically connected to the load.
- Torque Mode can be selected for applications where the motor shaft torque needs to be controlled independently of the speed.
- V/Hz Mode (output speed [712] in rpm) is used when several motors in parallel of different type or size are connected or if parallel motors are not mechanically connected to the load

213 Drive Mode		
Default:		Speed
Speed	0	The AC drive is speed controlled. Reference given= speed reference with ramp. Speed and torque limits can be set. Using "direct torque control" as motor control method.

213		Drive Mode
Torque	1	The AC drive is torque controlled. Reference given=torque reference without ramp. Speed and torque limit can be set. Using "direct torque control" as motor control method. <b>NOTE: No ramps active in the AC drive. Care must be taken.</b>
V/Hz	2	All control loops are related to frequency control. In this mode multi-motor applications are possible. V/Hz Mode using PWM modulation, can be used with Sinus filters. <b>NOTE: All the functions and menu read-outs with regard to speed and rpm (e.g. Max Speed = 1500 rpm, Min Speed=0 rpm, etc.) remain speed and rpm, although they represent the output frequency.</b>
V/Hz (VFX)	6	V/Hz using "direct torque control" giving smooth motor torque variations. More dependent on correct motor data than V/Hz (PWM).

**NOTE: "V/Hz" mode found in previous VFX drives is the same as the "V/Hz (VFX)" mode.**

## Reference control [214]

To control the speed of the motor, the AC drive needs a reference signal. This reference signal can be controlled by a remote source from the installation, the keyboard of the AC drive, or via communication (RS485, Fieldbus, or Wireless interfaces). Select the required reference control for the application in this menu.

214		Ref control
Default:		Remote
Remote	0	The reference signal comes from the analogue inputs of the terminal strip (terminals 1-22).
Keyboard	1	Reference is set with the + and - keys on the Control Panel. Can only be done in menu "Set/View reference [310]".
Com	2	The reference is set via communication (RS485, Fieldbus, or Wireless interfaces). See Section 9.5, page 86 for further information.
Option	3	The reference is set via an option. Only available if the option can control the reference value.

**NOTE: If the reference is switched from Remote to Keyboard, the last remote reference value will be the default value for the control panel.**

**NOTE: Drive should be stopped in case configured source of reference or run/stop control is lost, e.g. due to communication errors. Hence, it is highly recommended to use the available mechanisms to monitor the communication between the AC drive and the controlling equipment.**

See the following menus for more information:  
Keyboard [2645] and [2646]

Communication: RS485 [262], Fieldbus [263],  
Wireless [270]

## Run/Stop Control [215]

This function is used to select the source for run and stop commands. This is described on page 144.

Start/stop via analogue signals can be achieved by using function “Stp<MinSpd [342]”.

215 Run/Stp Ctrl		
Default:		Remote
Remote	0	The start/stop signal comes from the digital inputs of the terminal strip (terminals 1-22). For settings, see menu group [330] and [520].
Keyboard	1	Start and stop is set on the Control Panel.
Com	2	The start/stop is set via communication, i.e. via RS485, Fieldbus, or wireless interface. See Fieldbus or RS-232/485 option manual for details and Chapter 9.4 Start and stop commands, page 86.
Option	3	The start/stop is set via an option.

## Reset Control [216]

When the AC drive is stopped due to a failure, a reset command is required to make it possible to restart the AC drive. Use this function to select the source of the reset signal.

216 Reset Ctrl		
Default:		Remote+Keyb
Remote	0	The command comes from the inputs of the terminal strip (terminals 1-22).
Keyboard	1	The command comes from the command keys of the Control Panel.
Com	2	The command comes from communication (RS485, Fieldbus, wireless).
Remote + Keyb	3	The command comes from the inputs of the terminal strip (terminals 1-22) or the keyboard.
Com + Keyb	4	The command comes from communication (RS485, Fieldbus, wireless) or the keyboard.
Rem+Keyb +Com	5	The command comes from the inputs of the terminal strip (terminals 1-22), the keyboard or communication (RS485, Fieldbus, wireless).
Option	6	The command comes from an option. Only available if the option can control the reset command.

## Local/Remote key function [217]

The Toggle key on the keyboard, see Section 10.2.8, page 95, has two functions and is activated in this menu. As default the key is just set to operate as a Toggle key that moves you easily through the menus in the toggle loop. The second function of the key allows you to easily swap between Local and normal operation (set up via [214] and [215]) of the AC drive. Local mode can also be activated via a digital input. If both [2171] and [2172] is set to Standard, the function is disabled.

2171 LocRefCtrl		
Default:		Standard
Standard	0	Local reference control set via [214]
Remote	1	Local reference control via remote
Keyboard	2	Local reference control via keyboard
Com	3	Local reference control via communication

2172 LocRunCtrl		
Default:		Standard
Standard	0	Local Run/Stop control set via [215]
Remote	1	Local Run/Stop control via remote
Keyboard	2	Local Run/Stop control via keyboard
Com	3	Local Run/Stop control via communication

## Lock Code? [218]

To prevent the keyboard being used or to change the setup of the AC drive and/or process control, the keyboard can be locked with a password. This menu, “Lock Code [218]”, is used to lock and unlock the keyboard. Enter the password “291” to lock/unlock the keyboard operation. If the keyboard is not locked (default) the selection “Lock Code?” will appear. If the keyboard is already locked, the selection “Unlock Code?” will appear.

When the keyboard is locked, parameters can be viewed but not changed. The reference value can be changed and the AC drive can be started, stopped and reversed if these functions are set to be controlled from the keyboard.

218 Lock code?	
Default:	0
Range:	0-9999

## Rotation [219]

### Overall limitation of motor rotation direction

This function limits the overall rotation, either to left or right or both directions. This limit is prior to all other selections, e.g.: if the rotation is limited to right, a Run-Left command will be ignored. To define left and right rotation we assume that the motor is connected U-U, V-V and W-W.

### Speed Direction and Rotation

The speed direction can be controlled by:

- RunR/RunL commands on the control panel.
- RunR/RunL commands on the terminal strip (terminals 1-22).
- Via the serial interface options.
- The parameter sets.

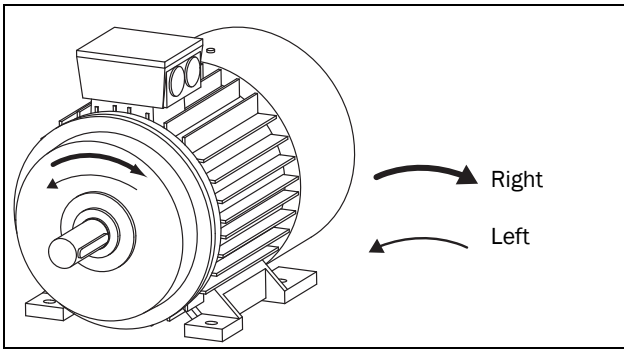

Fig. 105 Rotation.

In this menu you set the general rotation for the motor.

219		Rotation
Default:		R + L
R	1	Speed direction is limited to right rotation. The input and key RunL are disabled.
L	2	Speed direction is limited to left rotation. The input and key RunR are disabled.
R+L	3	Both speed directions allowed.

## Remote Signal Level/Edge [21A]

In this menu you select the way to control the inputs for RunR, RunL and Reset that are operated via the digital inputs on the terminal strip. The inputs are default set for level-control, and will be active as long as the input is made and kept high. When edge-control is selected, the input will be activated by the low to high transition of the input. See Chapter 7.2 Remote control functions, page 67 for more information.

21A		Level/Edge
Default:		Level
Level	0	The inputs are activated or deactivated by a continuous high or low signal. Is commonly used if, for example, a PLC is used to operate the AC drive.
Edge	1	The inputs are activated by a transition; for Run and Reset from "low" to "high" and for Stop from "high" to "low".



#### CAUTION!

Level controlled inputs **DO NOT** comply with the Machine Directive if the inputs are directly used to start and stop the machine.

**NOTE:** Edge controlled inputs can comply with the Machine Directive (see the Chapter 8. EMC and standards, page 83) if the inputs are directly used to start and stop the machine.

## Mains supply voltage [21B]



#### WARNING!

This menu must be set according to the AC drive product label and the supply voltage used. Wrong setting might damage the AC drive or brake resistor.

In this menu the nominal mains supply voltage connected to the AC drive can be selected. The setting will be valid for all parameter sets.

This menu specifies the AC supply voltage. The corresponding DC voltage is 1.34 times higher.

Once the supply voltage is set, this selection will not be affected by the Load Default command [243].

Brake chopper activation level is adjusted using the setting of [21B].

**NOTE:** The setting is affected by the "Load from CP" command [245] and if loading parameter file via EmoSoftCom.

<b>21B Supply Volts</b>		
Default:		Standard
Standard	0	Inverter default values
220-240 VAC	1	Only valid for VFX48/52
380-415 VAC	3	Only valid for VFX48/52/69
440-480 VAC	4	Only valid for VFX48/52/69
500-525 VAC	5	Only valid for VFX52/69
550-600 VAC	6	Only valid for VFX69
660-690 VAC	7	Only valid for VFX69

## Supply Type [21C]

Set supply voltage type.

<b>21C Supply Type</b>		
Default:		AC Supply
AC Supply	0	Normal AC supply
AFE Supply	1	DC supply voltage by AFE
DC Supply	2	DC supply voltage
AC/DC Suppl	3	AC/DC supply voltage

When changing to / from the “AFE Supply” selection, the following parameters are set to following values:

Menu	to AFE	from AFE
[523] DigIn 3	Sleep	Off
[542] DigOut 3	Run	Brake
[527] DigIn 7	Off	Off
[561] VIO 1 Dest	External Trip	Off
[562] VIO 1 Source	!D1	Off
[6151] CD 1	DigIn 7	Run

## CP Units [21E]

Menus to select control panel units.

### CP Unit torque [21E1]

Torque unit selection used by the control panel.

<b>21E1 CP Unit Torq</b>		
Default:		Nm
Nm	0	Newton meter is selected.
LbfFt	1	Pound foot is selected.

### CP Unit torque [21E2]

Power unit selection used by the control panel.

<b>21E2 CP Unit Pow</b>		
Default:		W
W	0	Watt is selected.
hp	1	Horse power is selected.

### CP Unit torque [21E3]

Temperature unit selection used by the control panel.

<b>21E3 CP Unit Temp</b>		
Default:		°C
°C	0	Celsius is selected.
°F	1	Fahrenheit is selected.

## 11.2.2 Motor Data [220]

In this menu you enter the motor data to adapt the AC drive to the connected motor. This is crucial for the control accuracy as well as different read-outs and analogue output signals.

Emotron VFX AC drive can control both Asynchronous motors and Permanent magnet synchronous motor (PMSM) select type of motor in menu [221].



### WARNING!

Do not work on a drive when a rotating Permanent Magnet synchronous motor is connected to it. A rotating PMSM motor energizes the drive including its power terminals.

Motor M1 is selected as default and motor data entered will be valid for motor M1. If you have more than one motor you need to select the correct motor in menu [212] before entering motor data.

**NOTE 1:** The parameters for motor data cannot be changed during run mode.

**NOTE 2:** The default settings are for a standard 4-pole motor according to the nominal power of the AC drive.

**NOTE 3:** Parameter set cannot be changed during run if the parameter set is set for different motors.

**NOTE 4:** Motor Data in the different sets M1 to M4 can be revert to default setting in menu “[243] Default>Set”.



### WARNING!

Enter the correct motor data to prevent dangerous situations and assure correct control.

## Motor Voltage [221]

Set the nominal motor voltage.

221  Motor Volts	
Default:	400 V for VFX48 500 V for VFX52 690 V for VFX 69
Range:	100-700 V
Resolution	1 V

**NOTE:** The Motor Volts value will always be stored as a 3 digit value with a resolution of 1 V.

## Motor Frequency [222]

Set the nominal motor frequency.

222  Motor Freq	
Default:	50 Hz
Range:	20.0 - 599.0 Hz
Resolution	0.1 Hz

## Motor Power [223]

Set the nominal motor power. If parallel motors, set the value as sum of motors power. The nominal motor power must be within the range of 1 - 150% of the AC drives nominal power.

223  Motor Power	
Default:	( $P_{NOM}$ ) W, AC drive
Range:	1-150% x $P_{NOM}$
Resolution	3 significant digits

**NOTE:** The Motor Power value will always be stored as a 3 digit value in W up to 999 W and in kW for all higher powers.

$P_{NOM}$  is the nominal AC drive power.

## Motor Current [224]

Set the nominal motor current. If parallel motors, set the value as sum of motors current.

224  Motor Curr	
Default:	( $I_{MOT}$ ) A (see Note 2 page 106)
Range:	25 - 150% x $I_{NOM}$ A

## Motor Speed [225]

Set the nominal asynchronous motor speed.

225  Motor Speed	
Default:	( $n_{MOT}$ ) rpm (see Note 2 page 106)
Range:	30 - 35940 rpm
Resolution	1 rpm, 4 sign digits



**WARNING!**  
Do NOT enter a synchronous (no-load) motor speed.

**NOTE:** Maximum speed [343] is not automatically changed when the motor speed is changed.

**NOTE:** Entering a wrong, too low value can cause a dangerous situation for the driven application due to high speeds.

## Motor Poles [226]

When the nominal speed of the motor is  $\leq 500$  rpm, the additional menu for entering the number of poles, [226], appears automatically. In this menu the actual pole number can be set which will increase the control accuracy of the AC drive.

226  Motor Poles	
Default:	4
Range:	2-144

## Motor Cos $\phi$ [227]

Set the nominal Motor cosphi (power factor).

227  Motor Cos $\phi$	
Default:	Cos $\phi_{NOM}$ (see Note 2 page 106)
Range:	0.45 - 1.00

## Motor ventilation [228]

Parameter for setting the type of motor ventilation. Affects the characteristics of the  $I^2t$  motor protection by lowering the actual overload current at lower speeds.

228  Motor Vent		
Default:	Self	
None	0	Limited $I^2t$ overload curve.
Self	1	Normal $I^2t$ overload curve. Means that the motor stands lower current at low speed.
Forced	2	Expanded $I^2t$ overload curve. Means that the motor stands almost the whole current also at lower speed.

When the motor has no cooling fan, None is selected and the current level is limited to 55% of rated motor current.

With a motor with a shaft mounted fan, Self is selected and the current for overload is limited to 87% from 20% of synchronous speed. At lower speed, the overload current allowed will be smaller.

When the motor has an external cooling fan, Forced is selected and the overload current allowed starts at 90% from rated motor current at zero speed, up to nominal motor current at 70% of synchronous speed.

Fig. 106 shows the characteristics with respect to Nominal Current and Speed in relation to the motor ventilation type selected.

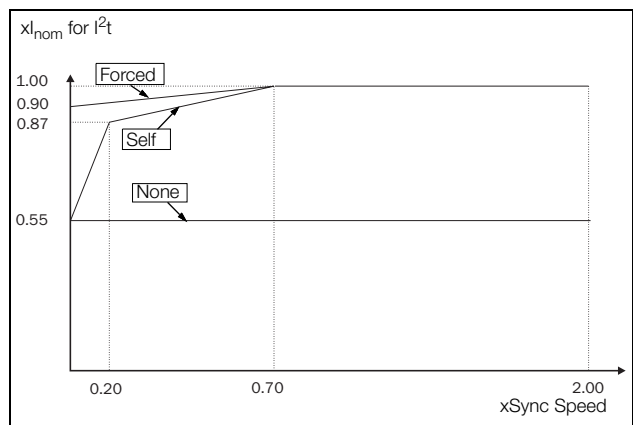

Fig. 106  $I^2t$  curves.

## Motor Identification Run [229]

This function is used when the AC drive is put into operation for the first time. To achieve an optimal control performance, fine tuning of the motor parameters using a motor ID run is needed. During the test run the display shows “Test Run” flashing.

To activate the Motor ID run, select either “Short” or “Extended” and press Enter. Then press RunL or RunR on the control panel to start the ID run. If menu “[219] Rotation” is set to L the RunR key is inactive and vice versa. The ID run can be aborted by giving a Stop command via the control panel or Enable input. The parameter will automatically return to OFF when the test is completed. The message “Test Run OK!” is displayed. Before the AC drive can be operated normally again, press the STOP/RESET key on the control panel.

During the Short ID run the motor shaft does not rotate. The AC drive measures the rotor and stator resistance.

During the Extended ID run the motor is powered on and rotates. The AC drive measures the rotor and stator resistance as well as the induction and the inertia for the motor.

229  Motor ID-Run		
Default:	Off, see Note	
Off	0	Not active
Short	1	Parameters are measured with injected DC current. No rotation of the shaft will occur.
Extended	2	Additional measurements, not possible to perform with DC current, are done directly after a short ID run. The shaft will rotate and must be disconnected from the load.



**WARNING!**  
During the extended ID RUN, the motor will rotate. Take safety measures to avoid unforeseen dangerous situations.

**NOTE:** To run the AC drive it is not mandatory for the ID RUN to be executed, but without it the performance will not be optimal.

**NOTE:** If the ID Run is aborted or not completed the message “Interrupted!” will be displayed. The previous data do not need to be changed in this case. Check that the motor data are correct.

## Motor Sound [22A]

22A  Motor Sound		
Default:	F (“Advanced” for models 48-293/295 and 48-365)	
F	1	Switching frequency 3 kHz
Advanced	4	Switching frequency and PWM mode setup via [22E]

## Encoder Feedback [22B]

Only visible if the Encoder option board is installed. This parameter enables or disables the encoder feedback from the motor to the AC drive. The parameter makes it possible to change sign of the measured speed if the encoder signal is inverted.

22B  Encoder		
Default:	Off	
Off	0	Encoder feedback disabled
On	1	Encoder feedback enabled
Off Inverted	2	Encoder feedback disabled. Change sign of the speed measured by the encoder.
On Inverted	3	Encoder feedback enabled. Change sign of the speed measured by the encoder.

## Encoder Pulses [22C]

Only visible if the Encoder option board is installed. This parameter describes the number of pulses per rotation for your encoder, i.e. it is encoder specific. For more information please see the encoder manual.

22C  Enc Pulses	
Default:	1024
Range:	5–16384

## Encoder Speed [22D]

Only visible if the Encoder option board is installed and added in menus 1x0. This parameter shows the measured motor speed. To check if the encoder is correctly installed, set Encoder Feedback [22B] to Off, run the AC drive at any speed and compare with the value in this menu. The value in this menu [22D] should be about the same as the motor speed [230]. If you get the wrong sign for the value, swap encoder input A and B.

22D  Enc Speed	
Unit:	Orpm
Resolution:	speed measured via the encoder

---

**NOTE:** If accessed via communication, the signal is unreliable at speeds outside -32768 ... 32767.

---

## Motor PWM [22E]

Menus for advanced setup of motor modulation properties (PWM = Pulse Width Modulation).

---

**Note:** Menus [22E1] - [22E3] are only visible if [22A] is set to "Advanced".

---

## PWM Fswitch [22E1]

Set the PWM switching frequency reference of the AC drive.

22E1	PWM Fswitch
Default:	3000 Hz (2 kHz for models 48-293/295 and 48-365)
Range	1.50 - 6.00kHz * **
Resolution	0.01kHz

\* Maximum is 8 kHz if [222] Motor freq > 400 Hz and if < 400 Hz max remains at 6 kHz.

\*\* The switching frequency is internally reduced down to minimum 1.5 kHz if the IGBT temperature is too high.

---

**NOTE:** At switching frequencies >3 kHz derating may become necessary.

---

---

**NOTE:** If the heat sink temperature gets too high the switching frequency is decreased to avoid tripping. This is done automatically in the AC drive. The default switching frequency is 3 kHz.

---

## Sinus Filter [22E2]

Parameters for sine filter. Sine filter values for Inductor L1 [22E22] and Capacitor C1 [22E23] can be found in the Technical Catalogue or on the sine filter rating plate.

## PWM Mode [22E21]

22E21		PWM Mode
Default:		Standard
Standard	0	Standard
Sine Filt	1	Sine Filter mode for use with output Sine Filters

**NOTE: Switching frequency is fixed when "Sine Filt" is selected. This means that it is not possible to control the switching frequency based on temperature.**

## Inductor L1 [22E22]

Sine filter inductance. Compensation applied when sine filter selected as PWM mode in [22E21].

22E22		Inductor L1
Default:		0 $\mu$ H
Range:		0-65535 $\mu$ H

## Capacitor C1 [22E23]

Sine filter capacitance. Compensation applied when sine filter selected as PWM mode in [22E21].

22E23		Capacitor C1
Default:		0 $\mu$ F
Range:		0-65535 $\mu$ F

## PWM Random [22E3]

22E3		PWM Random
Default:		Off
Off	0	Random modulation is Off.
On	1	Random modulation is active. Random frequency variation range is $\pm 1/8$ of level set in [E22E1].

## Udc filter [22E4]

Activating the Udc filter makes the drive less responsive to fast Udc changes. This can be useful to improve system stability when connected to a weak power grid but may reduce the dynamics of motor control.

22E4		Udc filter
Default:		Off
Off	0	The Udc filter is not active.
On	1	The Udc filter is active.

## Encoder Pulse counter [22F]

Only visible if the encoder option is installed. Shows the number of accumulated quadrature encoder pulses (QEP). It can be used as a position counter for hoisting and traveling motors. The counter value is held by a signed 32-bit register. It counts up in positive rotation direction and down in negative rotation direction. It can be pre-set, via communication, to any value within the bus format used (Int = 16 bits, Long = 32 bits).

22F		Enc Puls Ctr
Default:		0
Resolution		1

**Note: For a 1024 pulse encoder [22F] will count  $1024 * 4 = 4096$  pulses per turn.**

## Encoder fault and speed monitoring [22G]

Parameters for encoder fault monitoring and speed supervision by use of the encoder feedback for detecting speed deviation compared to internal speed reference signal. Similar speed deviation functionality is also available in the Crane option, with parameters for speed bandwidth and delay time.

Encoder fault trip conditions:

1. No encoder board detected after power up and AC drive is setup to use encoder.
2. Lost communication to encoder board for more than 2 seconds.
3. If no pulses detected for set delay time [22G1] and drive in Torque Limit (TL) or Current Limit (CL).

**Note: If encoder signals are missing or encoder cable disconnected, the measured speed will then be 0 rpm and the AC drive will run with Torque Limit (TL) at very low speed.**

**Note:** Other likely scenarios when encoder signals are lost during operation are tripped drive due to “Overcurrent Fast” or “Desat”.

Encoder speed deviation trip condition:  
Encoder speed outside set speed deviation band [22G2] for set delay time [22G1].

**Note:** Encoder speed deviation trip re-uses “Deviation 2” trip message with ID = 2.

### Encoder fault delay time [22G1]

Define the encoder fault and speed deviation delay time.

22G1 Enc F Delay	
Default:	Off
Range	Off, 0.01 - 10.00 s (Off = 0)

### Encoder fault speed deviation band [22G2]

Defines the max allowed speed deviation band = difference between measured encoder speed and speed ramp output.

22G2 Enc F Band	
Default:	10%
Range	0 - 400%

### Encoder max fault counter [22G3]

This is a measured signal showing the maximum time that the speed deviation has exceeded the allowed speed deviation band level, set in [22G2]. The parameter is intended to be used during commissioning for setting up [22G1] and [22G2] to avoid nuisance trips and can be cleared by setting it to 0.

22G3 Max EncFCtr	
Default:	0.000s
Range	0.00 - 10.00 s

**NOTE:** The value is volatile and lost at power down. It is possible to reset the value by clearing the parameter.

### EncoderOverride [22G4]

The selection “On” disables encoder and keeps running with observer, if reading unexpectedly few pulses. Ignores comm and pulse detection trips when enabled.

22G4 EncOverride		
Default:		Off
Off	0	Encoder override disabled.
On	1	Disables encoder and keeps running with observer, if reading unexpectedly few pulses.

### Phase order [22H]

Phase sequence for motor output. In this menu you can correct rotation direction on the motor by selecting “reverse” instead of switching the motor cables..

22H Phase order		
Default:		Normal
Normal	0	Normal phase order (U, V, W)
Reverse	1	Reverse phase order (U, W, V)

### Motor type [22I]

In this menu select type of motor. Emotron AC drives can control Asynchronous motors, Permanent Magnet Synchronous Motor and Synchronous Reluctance Motors.

22I Motor Type		
Default:		Async
Async	0	Asynchronous motor
PMSM	1	Permanent magnet synchronous motor
Sync Rel	2	Synchronous Reluctance motor

**NOTE:** If PMSM is selected in menu [22I] it is recommended to enter [22J] Extend data.

If the voltage mentioned on the permanent magnet motor type plate is given as a voltage per speed (no-load voltage/“xx rpm”), e.g. 205V/1000 rpm, the “Motor Voltage” for a nominal synchronous speed of 1500 rpm then can be calculated according to following example:

Motor synchronous speed = 1500 rpm  
 No-load voltage = 205V/1000rpm  
 Calculation of Motor Voltage setting:

$MotorVoltage[221]=$

$$\left(\frac{N_{motorsynchronous}}{N_{motornoload}}\right) \times NoLoadVoltage$$

$$MotorVoltage[221] = \left(\frac{1500rpm}{1000rpm}\right) \times 205V = 307V$$

**Note:** The “Motor Voltage” is not equal to the Equivalent DC Motor (EDCM) voltage as specified by some motor manufacturers. The “Motor Voltage” setting then can be calculated by:

$$MotorVoltage[221] = \frac{EDCM}{\sqrt{3}}V$$

## Extend data [22J]

Additional motor parameters for Permanent Magnet Synchronous Motors (PMSM) and Synchronous Reluctance motors.

This menu is only available if PMSM or Sync Rel is selected in menu [22I].

### BEMF [22J1]

Set the back EMF of the motor at the nominal operating point. This parameter may not be explicitly available from the manufacturer, but can then be computed from the electrical constant  $K_e$  and the nominal speed.

22J1	BEMF
Default:	Motor dependent (V)
Range:	100-700 V
Resolution	1 V

### Rs (mΩ/ph) [22J2]

Set the per phase resistance.

22J2	Rs (mΩ/ph)
Default:	Undef
Undef	Undefined
Range:	0.001-40000 mOhm

### Lsd (mH/ph) [22J3]

Set the per phase d-axis inductance.

22J3	Lsd (mH/ph)
Default:	Undef
Undef	Undefined
Range:	0.001-10000.000 mH

### Lsq (mH/ph) [22J4]

Set the per phase q-axis inductance.

22J4	Lsq (mH/ph)
Default:	Undef
Undef	Undefined
Range:	0.001-10000.000 mH

## 11.2.3 Motor Protection [230]

This function protects the motor against overload based on the standard IEC 60947-4-2.

### Motor I<sup>2</sup>t Type [231]

The motor protection function makes it possible to protect the motor from overload as published in the standard IEC 60947-4-2. It does this using “Motor I<sup>2</sup>t Current [232]” as a reference. The “Motor I<sup>2</sup>t Time [233]” is used to define the time behaviour of the function. The current set in [232] should be allowed infinite in time by the motor (thermal) specification/design. If for instance in [233] a time of 1000 s is chosen the upper curve of Fig. 107 is valid. The value on the x-axis is the multiple of the current chosen in [232]. The time [233] is the time that an overloaded motor is switched off or is reduced in power at 1.2 times the current set in [232].

231		Mot I <sup>2</sup> t Type
Default:		Trip
Off	0	I <sup>2</sup> t motor protection is not active.
Trip	1	When the I <sup>2</sup> t time is exceeded, the AC drive will trip on “Motor I <sup>2</sup> t”.
Limit T	2	This mode helps to keep the inverter running when the Motor I <sup>2</sup> t function is just before tripping the AC drive. The trip is replaced by current limiting with a maximum current level set by the value out of the menu [232]. In this way, if the reduced current can drive the load, the AC drive continues running. If there is no reduction in thermal load, the drive will trip.
Limit Spd	3	This mode is similar to “Limit T” but it limits the speed instead of the torque. This can be useful in for e.g. pump applications where the load increases with the speed. A minimum allowed speed can be set in menu [238]

---

**NOTE:** When Mot I<sup>2</sup>t Type=Limit, the AC drive can control the speed < MinSpeed to reduce the motor current.

---

## Motor I<sup>2</sup>t Current [232]

Sets the current limit for the motor I<sup>2</sup>t protection in percent of I<sub>MOT</sub>.

232 Mot I <sup>2</sup> t Curr	
Default:	100% of I <sub>MOT</sub>
Range:	0–150% of I <sub>MOT</sub> (set in menu [224])

**NOTE:** When the selection Limit is set in menu [231], the value must be above the no-load current of the motor.

## Motor I<sup>2</sup>t Time [233]

Sets the time of the I<sup>2</sup>t function. After this time the limit for the I<sup>2</sup>t is reached if operating with 120% of the I<sup>2</sup>t current value. Valid when start from 0 rpm.

**NOTE:** Not the time constant of the motor.

233 Mot I <sup>2</sup> t Time	
Default:	60 s
Range:	60–1200 s

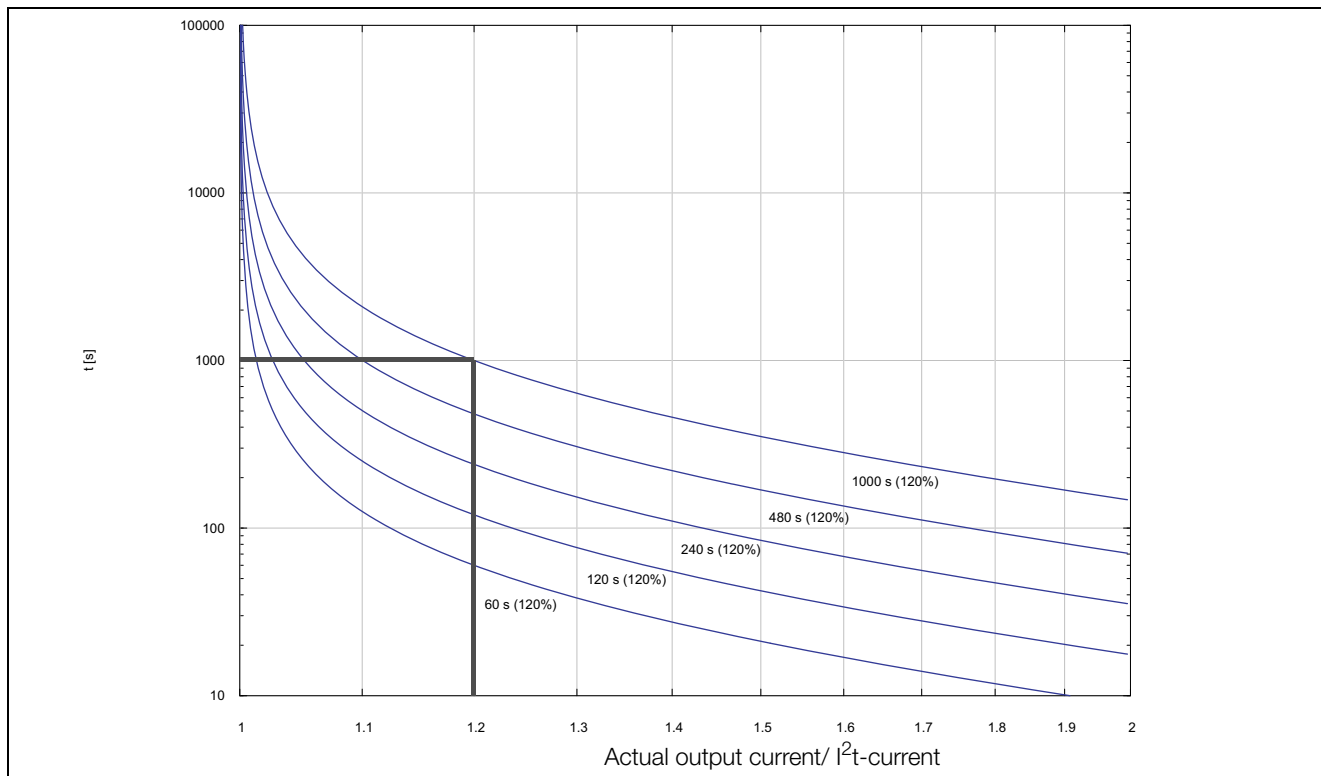

Fig. 107 I<sup>2</sup>t function

Fig. 107 shows how the function integrates the square of the motor current according to the “Mot I<sup>2</sup>t Curr [232]” and the “Mot I<sup>2</sup>t Time [233]”.

When the selection Trip is set in menu [231] the AC drive trips if this limit is exceeded.

When the selection Limit is set in menu [231] the AC drive reduces the torque if the integrated value is 95% or closer to the limit, so that the limit cannot be exceeded.

**NOTE:** If it is not possible to reduce the current, the AC drive will trip after exceeding 110% of the limit.

### Example

In Fig. 107 the thick grey line shows the following example.

- Menu “[232] Mot I<sup>2</sup>t Curr” is set to 100%.  
1.2 x 100% = 120%
- Menu “[233] Mot I<sup>2</sup>t Time” is set to 1000 s.

This means that the AC drive will trip or reduce the current (depending on the setting in menu [231]) after 1000 s if the current is 1.2 times of 100% nominal motor current.

## Thermal Protection [234]

This menu selects active sensors for PTC motor protection and activates/deactivates PT100 motor protection. Select active PT100 sensors in menu [236]. The PTC sensor connected to the first board is activated if two boards are installed but only one PTC sensor is activated.

Only visible if one or two PTC/PT100 option boards are installed. The motor thermistors (PTC) must comply with DIN 44081/44082. Please refer to the manual for the PTC/PT100 option board.

234 Thermal Prot		
Default:		Off
Off	0	PTC and PT100 motor protection are disabled.
1xPTC	1	Activates one PTC sensor.
PT100	2	Activates PT100 protection.
1xPTC+ PT100	3	Activate one PTC sensor and PT100 protection.
2xPTC	4	Activates two PTC sensors.
2xPTC+ PT100	5	Activates PTC sensors and PT100 protection.

**NOTE:** PTC option and PT100 selections can only be selected in menu [234] if one or two option boards are mounted.

**NOTE:** If you select the PTC option, the PT100 inputs as motor protection are ignored.

## Motor Class [235]

Only visible if the PTC/PT100 option board is installed. Set the class of motor used. The trip levels for the PT100 sensor will automatically be set according to the setting in this menu.

235 Motor Class		
Default:		F 140°C
A 100°C	0	
E 115°C	1	
B 120°C	2	
F 140°C	3	
F Nema 145°C	4	
H 165°C	5	

**NOTE:** This menu is only valid for PT 100.

## PT100 Inputs [236]

Sets which of PT100 inputs (3 inputs per board) that should be used for thermal protection. Deselecting not used PT100 inputs on the PTC/PT100 option board in order to ignore those inputs, i.e. extra external wiring is not needed if port is not used.

236 PT100 Inputs		
Default:		PT100 1+2+3
PT100 1	1	Channel 1 used for PT100 protection
PT100 2	2	Channel 2 used for PT100 protection
PT100 1+2	3	Channel 1+2 used for PT100 protection
PT100 3	4	Channel 3 used for PT100 protection
PT100 1+3	5	Channel 1+3 used for PT100 protection
PT100 2+3	6	Channel 2+3 used for PT100 protection
PT100 1+2+3	7	Channel 1+2+3 used for PT100 protection
PT100 1-4	8	Channel 1 - 4 used for PT100 protection
PT100 1-5	9	Channel 1 - 5 used for PT100 protection
PT100 1-6	10	Channel 1 - 6 used for PT100 protection

**NOTE:** This menu is only active if PT100 is enabled in menu [234].

## Motor PTC [237]

For AC drive sizes B to D (VFX48/52-003--074), C2 & D2 (VFX48-025--105), C69 & D69 (VFX69-002--058-54) and C2(69) & D2(69) (VFX69-002--058-20) there is optional possibility to directly connect motor PTC (not to be mixed up with PTC/PT100 option board, see Section 13.10 page 228).

In this menu the internal motor PTC hardware option is activated. This PTC input complies with DIN 44081/44082. For electrical specification please refer to the separate manual for the PTC/PT100 option board, same data applies (could be found on [www.emotron.com/www.cgglobal.com](http://www.emotron.com/www.cgglobal.com)).

This menu is only visible if a PTC (or resistor <2 kOhm) is connected to terminals X1: 78–79. See Section 4.5 page 54.

**NOTE:** This function is not related to PTC/PT100 option board.

To enable the function:

1. Connect the thermistor wires to X1: 78–79 or for testing the input, connect a resistor to the terminals. Use a resistor value between 50 and 2000 ohm.  
Menu [237] will now appear.
2. Activate input by setting menu “[237] Motor PTC”=On.

If activated and <50 ohm a sensor error trip will occur. The fault message “Motor PTC” is shown.

If the function is disabled and the PTC or resistor is removed, the menu will disappear after the next power on.

237		Motor PTC
Default:		Off
Off	0	Motor PTC protection is deactivated
On	1	Motor PTC protection is activated

## I<sup>2</sup>t Min Spd [238]

Configures minimum allowed speed when [231] is set to “Limit Spd”. E.g. used for pumps that should not operate under some speed.

238		I <sup>2</sup> t Min Spd
Default:		0 rpm
Range:		0 - Max Speed
Dependent on:		Set/View ref [310]

## 11.2.4 Parameter Set Handling [240]

There are four different parameter sets available in the AC drive. These parameter sets can be used to set the AC drive up for different processes or applications such as different motors used and connected, activated PID controller, different ramp time settings, etc.

A parameter set consists of all parameters with the exception of the Global parameters. The Global parameters are only able to have one value for all parameter sets.

Following parameters are Global: [211] Language, [217] Local Remote, [218] Lock Code, [220] Motor Data, [241] Select Set, [260] Serial Communication and [21B]Mains Supply Voltage.

**NOTE:** Actual timers are common for all sets. When a set is changed the timer functionality will change according to the new set, but the timer value will stay unchanged.

## Select Set [241]

Here you select the parameter set. Every menu included in the parameter sets is designated A, B, C or D depending on the active parameter set. Parameter sets can be selected from the keyboard, via the programmable digital inputs or via serial communication. Parameter sets can be changed during the run. If the sets are using different motors (M1 to M4) the set will be changed only when the motor is stopped.

241		Select Set
Default:		A
A	0	Fixed selection of one of the 4 parameter sets A, B, C or D.
B	1	
C	2	
D	3	
DigIn	4	Parameter set is selected via a digital input. Define which digital input in menu “[520] Digital inputs”.
Com	5	Parameter set is selected via serial communication.
Option	6	The parameter set is set via an option. Only available if the option can control the selection.

The active set can be viewed with function [721] VSD status.

**NOTE:** Parameter set cannot be changed during run if the parameter set includes change of the motor set (M2-M4). In this case always stop the motor before changing parameter set.

**Prepare parameter Set when different Motor data M1 - M4:**

1. Select desired parameter Set to be set in [241] A - D.
2. Select "Motor Set [212]" if other than the default Set M1.
3. Set relevant motor data in the Menu group [220].
4. Set other desired parameter settings to belong to this parameter Set.

To prepare a Set for another motor, repeat these steps.

## Copy Set [242]

This function copies the content of a parameter set into another parameter set.

242 Copy Set		
Default:		A>B
A>B	0	Copy set A to set B
A>C	1	Copy set A to set C
A>D	2	Copy set A to set D
B>A	3	Copy set B to set A
B>C	4	Copy set B to set C
B>D	5	Copy set B to set D
C>A	6	Copy set C to set A
C>B	7	Copy set C to set B
C>D	8	Copy set C to set D
D>A	9	Copy set D to set A
D>B	10	Copy set D to set B
D>C	11	Copy set D to set C

**NOTE:** The actual value of menu [310] will not be copied into the other set.

A>B means that the content of parameter set A is copied into parameter set B.

## Load Default Values Into Set [243]

With this function three different levels (factory settings) can be selected for the four parameter sets. When loading the default settings, all changes made in the software are set to factory settings. This function also includes selections for loading default settings to the four different Motor Data Sets.

243 Default>Set		
Default:		A
A	0	Only the selected parameter set will revert to its default settings.
B	1	
C	2	
D	3	
ABCD	4	All four parameter sets will revert to the default settings.
Factory	5	All settings, except [211], [221]-[228], [261], [3A1] and [923], will revert to the default settings.
M1	6	Only the selected motor set will revert to its default settings.
M2	7	
M3	8	
M4	9	
M1M2M3 M4	10	All four motor sets will revert to default settings.

**NOTE:** Trip log hour counter and other VIEW ONLY menus are not regarded as settings and will be unaffected.

**NOTE:** If "Factory" is selected, the message "Sure?" is displayed. Press the + key to display "Yes" and then Enter to confirm.

**NOTE:** The parameters in menu "[220] Motor data", are not affected by loading defaults when restoring parameter sets A-D.

## Copy All Settings to Control Panel [244]

All the settings can be copied into the control panel including the motor data. Start commands will be ignored during copying.

244  Copy to CP		
Default:	No Copy	
No Copy	0	Nothing will be copied
Copy	1	Copy all settings

**NOTE:** The actual value of menu [310] will not be copied into control panel memory set.

## Load Settings from Control Panel [245]

This function can load all four parameter sets from the control panel to the AC drive. Parameter sets from the source AC drive are copied to all parameter sets in the target AC drive, i.e. A to A, B to B, C to C and D to D.

Start commands will be ignored during loading.

245  Load from CP		
Default:	No Copy	
No Copy	0	Nothing will be loaded.
A	1	Data from parameter set A is loaded.
B	2	Data from parameter set B is loaded.
C	3	Data from parameter set C is loaded.
D	4	Data from parameter set D is loaded.
ABCD	5	Data from parameter sets A, B, C and D are loaded.
A+Mot	6	Parameter set A and Motor data are loaded.
B+Mot	7	Parameter set B and Motor data are loaded.
C+Mot	8	Parameter set C and Motor data are loaded.
D+Mot	9	Parameter set D and Motor data are loaded.
ABCD+Mot	10	Parameter sets A, B, C, D and Motor data are loaded.
M1	11	Data from motor 1 is loaded.
M2	12	Data from motor 2 is loaded.
M3	13	Data from motor 3 is loaded.
M4	14	Data from motor 4 is loaded.
M1M2M3 M4	15	Data from motor 1, 2, 3 and 4 are loaded.
All	16	All data is loaded from the control panel.

**NOTE:** Loading from the control panel will not affect the value in menu [310].

## ComFlt Set [246]

This menu specifies the parameter set that should be loaded when a communication error occurs, if the communication fault mode is set to change parameter set (See menus [2641], [2643] and [2647]). The digital output / relay “ComFlt Set” is activated when a communication error changes the parameter set.

**NOTE:** Menu [241] must be set to “Com” (5) for this menu [246] to be active.

246  ComFlt Set		
Default:	Keep Last	
A	0	Data from parameter set A is loaded.
B	1	Data from parameter set B is loaded.
C	2	Data from parameter set C is loaded.
D	3	Data from parameter set D is loaded.
DigIn	4	Parameter set is selected via a digital input. Define which digital input in menu [520] Digital inputs.
Keep Last	5	Do not change parameter set.

## AnInFlt Set [247]

Parameter set to change to upon losing AnIn reference signal if AnIn FltMode [51D1] is set to “Change PSet”.

247 <b>AnInFlt Set</b>		
Default:	Keep Last	
A	0	Data from parameter set A is loaded.
B	1	Data from parameter set B is loaded.
C	2	Data from parameter set C is loaded.
D	3	Data from parameter set D is loaded.
DigIn	4	Parameter set is selected via a digital input. Define which digital input in menu [520] Digital inputs.
Keep Last	5	Do not change parameter set.

## 11.2.5 Trip Autoreset/Trip Conditions [250]

The benefit of this feature is that occasional trips that do not affect the process will be automatically reset. Only when the failure keeps on coming back, recurring at defined times and therefore cannot be solved by the AC drive, will the unit give an alarm to inform the operator that attention is required.

For all trip functions that can be activated by the user you can select to control the motor down to zero speed according to set deceleration ramp to avoid water hammer.

Also see Section 12.2, page 218.

### Autoreset example

In an application it is known that the main supply voltage sometimes disappears for a very short time, a so-called “dip”. That will cause the AC drive to trip an “Undervoltage alarm”. Using the Autoreset function, this trip will be acknowledged automatically.

- Enable the Autoreset function by making the reset input continuously high.
- Activate the Autoreset function in the menu [2511], Number of trips.
- In menu [2525] Undervoltage, select the trip conditions that shall be allowed to be automatically reset by the Autoreset function, after the set delay time has expired.

## Autoreset Control [251]

### Number of Trips [2511]

Any number set above 0 activates the Autoreset. This means that after a trip, the AC drive restarts automatically according to the number of attempts selected. No restart attempts takes place unless all conditions are normal.

If the Autoreset counter (not visible) is greater than the selected number of attempts, the Autoreset cycle is interrupted. No Autoreset then takes place.

If there are no trips for more than 10 minutes, the Autoreset counter decreases by one.

If the maximum number of trips has been reached, the trip message hour counter (8x0 menu) is marked with an "A". Trips can be reset with a normal reset, but to re-activate the auto-reset functionality the auto-reset counter must be reset. This is done by de-activating the always high remote-reset input and then activating it again.

### Example:

- Number of allowed autoreset attempts [2511]= 5.
- Within 10 minutes 6 trips occur.
- At the 6th trip there is no autoreset, because the autoreset counter is set to allow only 5 attempts to autoreset a trip.
- To reset the autoreset counter, de-activate the always high remote-reset input and then activate it again.
- The autoreset counter is now zero.

2511 No of Trips	
Default:	0 (no Autoreset)
Range:	0–10 attempts

**NOTE: An auto reset is delayed by the remaining ramp time.**

### Enable Autoreset [2512]

The selection “On” enables the auto-reset function without an active digital reset signal. This makes it possible to use the auto-reset function without connecting a digital reset signal.

2512 Autores Enb		
Default:	DigIn	
DigIn	0	Digital reset signal.
On	1	Enables the auto-reset function.

## Drive Protection [252]

### Over temperature [2521]

Delay time starts counting when the fault is gone. When the time delay has elapsed, the alarm will be reset if the function is active.

2521 Over temp	
Default:	Off
Range:	Off, 1–3600 s (Off=0)

**NOTE: An auto reset is delayed by the remaining ramp time.**

### Over volt D [2522]

Delay time starts counting when the fault is gone. When the time delay has elapsed, the alarm will be reset if the function is active.

2522 Over volt D	
Default:	Off
Range:	Off, 1–3600 s (Off=0)

**NOTE: An auto reset is delayed by the remaining ramp time.**

### Over volt G [2523]

Delay time starts counting when the fault is gone. When the time delay has elapsed, the alarm will be reset if the function is active.

2523 Over volt G	
Default:	Off
Range:	Off, 1–3600 s (Off=0)

### Over volt [2524]

Delay time starts counting when the fault is gone. When the time delay has elapsed, the alarm will be reset if the function is active.

2524 Over volt	
Default:	Off
Range:	Off, 1–3600 s (Off=0)

### Under voltage [2525]

Delay time starts counting when the fault is gone. When the time delay has elapsed, the alarm will be reset if the function is active.

2525 Under volt	
Default:	Off
Range:	Off, 1–3600 s (Off=0)

### Over current F [2526]

Delay time starts counting when the fault is gone. When the time delay has elapsed, the alarm will be reset if the function is active.

2526 Over curr F	
Default:	Off
Range:	Off, 1–3600 s (Off=0)

### Power Fault [2527]

Delay time starts counting when the fault is gone. When the time delay has elapsed, the alarm will be reset if the function is active.

2527 Power Fault	
Default:	Off
Range:	Off, 1–3600 s (Off=0)

### Liquid cooling low level [2528]

Delay time starts counting when the fault disappears. When the time delay has elapsed, the alarm will be reset if the function is active.

2528 LC Level	
Default:	Off
Range:	Off, 1–3600 s (Off=0)

### Liquid Cooling Low level Trip Type [2529]

Select the preferred way to react to an alarm trip.

2529 LC Level TT		
Default:	Trip	
Trip	0	The motor will coast
Deceleration	1	The motor will decelerate

### Motor Protection [253]

#### Motor Lost [2531]

Delay time starts counting when the fault is gone. When the time delay has elapsed, the alarm will be reset if the function is active.

2531 Motor Lost	
Default:	Off
Range:	Off, 1–3600 s (Off=0)

**NOTE:** Only visible when Motor Lost is selected in menu [423].

#### Locked Rotor [2532]

Delay time starts counting when the fault is gone. When the time delay has elapsed, the alarm will be reset if the function is active.

2532 LockedRotor	
Default:	Off
Range:	Off, 1–3600 s (Off=0)

#### Motor I<sup>2</sup>t [2533]

Delay time starts counting when the fault is gone. When the time delay has elapsed, the alarm will be reset if the function is active.

2533 Motor I <sup>2</sup> t	
Default:	Off
Range:	Off, 1–3600 s (Off=0)

## Motor I<sup>2</sup>t Trip Type [2534]

Select the preferred way to react to a Motor I<sup>2</sup>t trip.

2534 Motor I <sup>2</sup> tTT		
Default:	Trip	
Trip	0	The motor will coast
Deceleration	1	The motor will decelerate

## PT100 [2535]

Delay time starts counting when the fault is gone. When the time delay has elapsed, the alarm will be reset if the function is active.

2535 PT100		
Default:	Trip	
Trip	0	The motor will coast
Deceleration	1	The motor will decelerate

## PT100 Trip Type [2536]

Delay time starts counting when the fault is gone. When the time delay has elapsed, the alarm will be reset if the function is active.

2536 PT100 TT		
Default:	Trip	
Trip	0	The motor will coast
Deceleration	1	The motor will decelerate

## PTC [2537]

Delay time starts counting when the fault is gone. When the time delay has elapsed, the alarm will be reset if the function is active.

2537 PTC		
Default:	Off	
Range:	Off, 1–3600 s (Off=0)	

## PTC Trip Type [2538]

Select the preferred way to react to a PTC trip.

2538 PTC TT		
Default:	Trip	
Trip	0	The motor will coast
Deceleration	1	The motor will decelerate

## Over Speed [2539]

Delay time starts counting when the fault is gone. When the time delay has elapsed, the alarm will be reset if the function is active.

2539 Over speed	
Default:	Off
Range:	Off, 1–3600 s (Off=0)

## External Motor Temperature [253A]

Delay time starts counting when the fault disappears. When the time delay has elapsed, the alarm will be reset if the function is active.

253A Ext MotTemp	
Default:	Off
Range:	Off, 1–3600 s (Off=0)

## External Motor Trip Type [253B]

Select the preferred way to react to an alarm trip.

253B Ext Mot TT		
Default:	Trip	
Trip	0	The motor will coast
Deceleration	1	The motor will decelerate

## Brake Fault [253C]

Delay time starts counting when the fault disappears. When the time delay has elapsed, the alarm will be reset if the function is active.

253C Brk Fault	
Default	Off
Range:	Off, 1–3600 s (Off=0)

## Encoder [253D]

Encoder delay time, starts counting when the fault disappears. When the time delay has elapsed, the alarm will be reset if the function is active.

253D Encoder	
Default:	Off
Range:	Off, 1–3600 s (Off=0)

### Torque Limitation Trip [253E]

Delay time starts counting when the fault disappears. When the time delay has elapsed, the alarm will be reset if the function is active.

<b>253E TL Trip</b>	
Default:	Off
Range:	Off, 1–3600 s (Off=0)

### Torque Limitation Trip Type [253F]

Select the preferred way to react to an alarm trip.

<b>253F TL Trip TT</b>		
Default:	Trip	
Trip	0	The motor will coast
Deceleration	1	The motor will decelerate

### Comm & I/O [254]

#### Communication Error [2541]

Delay time starts counting when the fault is gone. When the time delay has elapsed, the alarm will be reset if the function is active.

<b>2541 Com Error</b>	
Default:	Off
Range:	Off, 1–3600 s (Off=0)

#### Communication Error Trip Type [2542]

Select the preferred way to react to a communication trip.

<b>2542 Com ErrorTT</b>		
Default:	Trip	
Trip	0	The motor will coast
Deceleration	1	The motor will decelerate

#### AnIn<Offset [2543]

Delay time starts counting when the fault is gone. When the time delay has elapsed, the alarm will be reset if the function is active.

<b>2543 AnIn&lt;Offset</b>	
Default:	Off
Range:	Off, 1–3600 s (Off=0)

#### AnIn Trip type [2544]

Select the preferred way to react to an AnIn<Offset alarm trip.

<b>2544 AnIn TT</b>		
Default:	Trip	
Trip	0	The motor will coast
Deceleration	1	The motor will decelerate

## Load monitor [255]

### Min Alarm [2551]

Delay time starts counting when the fault is gone. When the time delay has elapsed, the alarm will be reset if the function is active.

<b>2551 Min Alarm</b>	
Default:	Off
Range:	Off, 1–3600 s (Off=0)

### Min Alarm Trip Type [2552]

Select the preferred way to react to a min alarm trip.

<b>2552 Min AlarmTT</b>		
Default:	Trip	
Trip	0	The motor will coast
Deceleration	1	The motor will decelerate

### Max Alarm [2553]

Delay time starts counting when the fault is gone. When the time delay has elapsed, the alarm will be reset if the function is active.

<b>2553 Max Alarm</b>	
Default:	Off
Range:	Off, 1–3600 s (Off=0)

### Max Alarm Trip Type [2554]

Select the preferred way to react to a max alarm trip.

<b>2554 Max AlarmTT</b>		
Default:	Trip	
Trip	0	The motor will coast
Deceleration	1	The motor will decelerate

## Pump [256]

### Pump [2561]

Delay time starts counting when the fault is gone. When the time delay has elapsed, the alarm will be reset if the function is active.

<b>2561 Pump</b>	
Default:	Off
Range:	Off, 1–3600 s (Off=0)

## Crane [257]

### Crane deviation [2571]

Deviation delay time, starts counting when the fault is gone. When the time delay has elapsed, the alarm will be reset if the function is active.

2571 CraneDeviat	
Default:	Off
Range:	Off, 1–3600 s (Off=0)

### Crane Communication [2572]

Crane Communication delay time, starts counting when the fault is gone. When the time delay has elapsed, the alarm will be reset if the function is active.

2572 Crane Comm	
Default:	Off
Range:	Off, 1–3600 s (Off=0)

## External Trips [258]

### External Trip 1 [2581]

Delay time starts counting when the fault is gone. When the time delay has elapsed, the alarm will be reset if the function is active.

2581 Ext Trip 1	
Default:	Off
Range:	Off, 1–3600 s (Off=0)

### External Trip 1 Type [2582]

Select the preferred way to react to an alarm trip.

2582 ExtTrip1 TT		
Default:	Trip	
Trip	0	The motor will coast
Deceleration	1	The motor will decelerate

### External Trip 2 [2583]

Delay time starts counting when the fault is gone. When the time delay has elapsed, the alarm will be reset if the function is active.

2583 Ext Trip 2	
Default:	Off
Range:	Off, 1–3600 s (Off=0)

## External Trip Type 2 [2584]

Select the preferred way to react to an alarm trip.

2584 ExtTrip2 TT		
Default:	Trip	
Trip	0	The motor will coast
Deceleration	1	The motor will decelerate

### External Trip 3 [2585]

Delay time starts counting when the fault is gone. When the time delay has elapsed, the alarm will be reset if the function is active.

2585 Ext Trip 3	
Default:	Off
Range:	Off, 1–3600 s (Off=0)

### External Trip 3 Type [2586]

Select the preferred way to react to an alarm trip.

2586 ExtTrip3 TT		
Default:	Trip	
Trip	0	The motor will coast
Deceleration	1	The motor will decelerate

### External Trip 4 [2587]

Delay time starts counting when the fault is gone. When the time delay has elapsed, the alarm will be reset if the function is active.

2587 Ext Trip 4	
Default:	Off
Range:	Off, 1–3600 s (Off=0)

### External Trip Type 4 [2588]

Select the preferred way to react to an alarm trip.

2588 ExtTrip4 TT		
Default:	Trip	
Trip	0	The motor will coast
Deceleration	1	The motor will decelerate

## 11.2.6 Serial Communication [260]

The integrated RS485 interface on terminal X1: A+ and B- will always be enabled regardless of setting in menu [261] Comm type. Further, it may be used in parallel to any Fieldbus option on X4 interface.

Menu [262] RS232/485 and its sub menus are used to configure the integrated RS485 interface.

This function is to define the communication parameters for serial communication. There are two types of options available for serial communication, RS232/485 (Modbus/RTU) and fieldbus modules (CANopen, Profibus, DeviceNet, Modbus/TCP, Profinet IO, EtherCAT and EtherNet/IP).

For more information see Chapter 9. Communication, page 85 and respective option manual.

### Comm Type [261]

Select RS232/485 [262] or Fieldbus [263].

261		Com Type
Default:		RS232/485
RS232/485	0	Integrated RS485 interface enabled. Fieldbus interface on X4 disabled (RESET).
Fieldbus	1	Fieldbus selected (CANopen, Profibus, DeviceNet, Modbus/TCP, Profinet IO, EtherCAT or EtherNet/IP). Integrated RS485 interface enabled (can be used in parallel to fieldbus option).

**NOTE: Toggling the setting in this menu will perform a soft reset (re-boot) of the Fieldbus module.**

### RS232/485 [262]

Press Enter to set up the parameters for RS-232/485 (Modbus/RTU) communication.

262	RS232/485
-----	-----------

### Baud rate [2621]

Set the baud rate for the communication.

**NOTE: This address is only used for the integrated/isolated RS485 option.**

2621		Baudrate
Default:		9600
2400	0	Selected baud rate
4800	1	
9600	2	
19200	3	
38400	4	
57600	5	
115200	6	

### Address [2622]

Enter the unit address for the AC drive.

**NOTE: This address is only used for the integrated/isolated RS485 option.**

2622		Address
Default:		1
Selection:		1-247

### Fieldbus [263]

Press Enter to set up the parameters for fieldbus communication.

263	Fieldbus
-----	----------

### Address [2631]

Enter/view the unit/node address of the AC drive. Read and write access for CANopen, Profibus, DeviceNet. Read - only for EtherCAT.

2631		Address
Default:		62
Range:		CANopen 1-127, Profibus 0-126, DeviceNet 0-63
Node address valid for CANopen (RW), Profibus(RW), DeviceNet (RW) and EtherCAT (RO).		

## Process Data Mode [2632]

Enter the mode of process data (cyclic data). For further information, see the Fieldbus option manual.

**NOTE:** For CANopen module this menu is forced to "Basic".

2632 PrData Mode		
Default:		Basic
None	0	Control/status information is not used.
Basic	4	4 byte process data control/status information is used.
Extended	8	4 byte process data (same as Basic setting) + additional proprietary protocol for advanced users is used.

## Read/Write [2633]

Select read/write to control the inverter over a Fieldbus network. For further information, see the Fieldbus option manual.

2633 Read/Write		
Default:		RW
RW	0	Read and write
Read	1	Read only
Valid for process data. Select R (read only) for logging process without writing process data. Select RW in normal cases to control inverter.		

## Additional Process Values [2634]

Define the number of additional process values sent in cyclic messages.

**NOTE:** For CANopen module this menu is forced to "8".

2634 AddPrValues	
Default:	0
Range:	0-8

## CAN Baudrate [2635]

Set the baud rate for CANopen Fieldbus.

**NOTE:** Used for CANopen module only

2635 CAN Baudrate	
Default:	8
0	10 kbps
1	20 kbps
2	50 kbps
3	Reserve
4	100 kbps
5	125 kbps
6	250 kbps
7	500 kbps
8	1 Mbps
9	Auto *

\* Under normal traffic conditions, i.e. with cyclic bus traffic above 2 Hz, the baudrate should be detected within 5 seconds.

**NOTE:** The automatic baud rate detection will NOT work if there is no traffic on the network.

## Communication Fault [264]

Main menu for communication fault/warning settings. For further details please see the Fieldbus option manual.

Menus [2641] and [2642] are specifically used for Fieldbus option mounted on interface X4.

Menus [2643] and [2644] are specifically used for integrated RS485 interface on X1: A+ and B-.

## Communication Fault Mode [2641]

Selects action if a Fieldbus fault is detected.

2641 ComFlt Mode		
Default:	Off	
Off	0	No communication supervision.
Trip	1	Fieldbus selected: The AC drive will trip if: 1. The internal communication between the control board and fieldbus option is lost for time set in parameter [2642]. 2. If a serious network error has occurred.
Warning	2	Fieldbus selected: The AC drive will give a warning if: 1. The internal communication between the control board and fieldbus option is lost for time set in parameter [2642]. 2. If a serious network error has occurred.
Change PSet	3	Same as Warning but combined with a change of parameter set according to the setting in [246].

**NOTE: Menu [214] and/or [215] must be set to COM to activate the communication fault function.**

## Communication Fault Time [2642]

Defines the delay time for the Fieldbus trip/warning.

2642 ComFlt Time	
Default:	0,5 s
Range:	0.1-15 s

## 485 Fault Mode [2643]

Selects action for timeout on integrated RS485 interface on X1: A+ and B-.

2643 485Flt Mode		
Default:	Off	
Off	0	No communication supervision.
Trip	1	The AC drive will trip if there is no communication for time set in parameter [2644].
Warning	2	The AC drive will give a warning if there is no communication for time set in parameter [2644].
Change Pset	3	Same as Warning but combined with a change of parameter set according to the setting in [246].

**NOTE: Menu [214] and/or [215] must be set to COM to activate the communication fault function.**

## 485 Fault Time [2644]

Defines the delay time for the integrated RS485 trip/warning.

2644 485Flt Time	
Default:	0.5 s
Range:	0.1-15 s

## Keyboard Communication Fault Mode [2645]

When keyboard is removed in drive running condition and "[214] Ref Control" or "[215] Run/Stop Ctrl" is set to "Keyboard" the drive should come to stop.

2645 KbdComFMode		
Default:	Trip	
Off	0	No supervision of keyboard.
Trip	1	The drive will trip after time set in parameter [2646] if keyboard/control board is removed.
Warning	2	The drive will give a warning after time set in parameter [2646] if the keyboard/control board is removed.

## Keyboard Communication Fault Time [2646]

Defines the delay time for detection of a removed control panel provided that 2645 is either trip or warning.

2646 KbdComFTime	
Default:	2 s
Range:	0.1 s - 15 s

## Communication fault for control panel port

This feature enables communication fault for external controlling equipment connected to the CP port. Most importantly this enables detection if a wireless connection, via BLE or WiFi CP, is disconnected.

Fault is only enabled if all of following conditions are met:

- "[214] Ref Control" or "[215] Run/Stop Ctrl" is set to "Com".
- A device connected to the CP port has written to any of the communication command registers:
  - Run (2 or 42902)
  - RunR (3 or 42903)
  - RunL (4 or 42904)
  - Reference (42905)
- Communication command Run and one or both of RunR or RunL are set.
- Function enabled (Trip or Warning) in menu "[2647] CPportFMode"
- No communication on the control panel port for "[2648] CPportFTime" X seconds.

## Control Panel port Fault Mode [2647]

2647 CPportFMode		
Default:		Trip
Off	0	No supervision of the control panel.
Trip	1	The drive will trip after time set in parameter [2648] if control panel is removed.
Warning	2	The drive will give a warning after time set in parameter [2648] if the control panel is removed.
Change Pset	3	Same as Warning but combined with a change of parameter set according to the setting in [246].

## Control Panel port Fault Time [2648]

2648 CPportFTime	
Default:	10.0 s
Range:	0.1 s - 15.0 s

## Ethernet [265]

Settings for Ethernet module (Modbus/TCP, Profinet IO). For further information, see the Fieldbus option manual.

**NOTE:** To reach a higher level of cybersecurity according to EU's Directive NIS2, IEC 62443-4-1 the menus [2656] FTP Server and menu [2657] WEB Server may be used to disable FTP and WEB servers for Industrial Ethernet bus options.

**NOTE:** The Ethernet module must be rebooted to activate the settings below. For example, by toggling parameter [261]. Non-initialised settings are indicated by flashing display text.

## IP Address [2651]

2651 IP Address	
Default:	0.0.0.0

## MAC Address [2652]

2652 MAC Address	
Default:	An unique number for the Ethernet module.

## Subnet Mask [2653]

2653 Subnet Mask	
Default:	0.0.0.0

## Gateway [2654]

2654 Gateway	
Default:	0.0.0.0

## DHCP [2655]

2655 DHCP		
Default:		Off
Off	0	
On	1	

## FTP Server [2656]

Enable/disable access to FTP server for cybersecurity reasons.

2656 FTP Server		
Default:		Off
Off	0	
On	1	

## WEB Server [2657]

Enable/disable access to WEB server for cybersecurity reasons.

2657 WEB Server		
Default:		Off
Off	0	
On	1	

## Fieldbus Signals [266]

Defines mapping for additional process values. For further information, see the Fieldbus option manual.

## FB S1/Wr1 - FB S8/Wr8 [2661]-[2668]

Used to create a block of parameters which can be written via communication.

2661 FB S1/Wr1	
Default:	0
Range:	0-65535

## FB S9/Rd1 - FB S16/Rd8 [2669]-[266G]

Used to create a block of parameters which can be read via communication.

2669 FB S9/Rd1	
Default:	0
Range:	0-65535

**NOTE:** For Modbus all 16 fieldbus mappings can be used either as read or write. Configuration of register map is made menu [2661]-[266G] or Modbus range 42801-42816. Register read/write access is made in Modbus range 42821-42836.

## FB Status [269]

Sub menu showing status of Fieldbus parameters. Please see the Fieldbus manual for detailed information.

269 FB Status	
---------------	--

## 11.2.7 Wireless [270]

Parameters for configuring wireless communication links such as WiFi or Bluetooth Low Energy (BLE). Changing any of these parameters will trigger a reconfiguration action that could result in a slight delay of pressed buttons / menu change.

### Wireless Mode [271]

Available options depend on capability of the connected control panel.

271 WirelessMode		
Default		Off
Off	0	Wireless interfaces turned off
WiFi	1	WiFi interface enabled
BLE	2	Bluetooth Low Energy interface enabled

### WiFi Options [272]

This menu is hidden unless menu "WirelessMode [271]" is set to WiFi.

After a sub-menu has been changed the response from the WiFi module can be observed in menu [272A] WiFi Status. If everything went well a "Config OK" is expected to be shown for 60 seconds.

### WiFi Mode [2721]

Configures the 2.4 GHz WiFi interface of the control panel to either act as an AccessPoint (allowing clients to connect to the drive) or as station (i.e. connect to an already existing WiFi network as a client).

**NOTE:** Only one client can connect and communicate with the drive at same time.

2721 WiFi Mode		
Default		AccessPoint
AccessPoint	0	Configure WiFi interface to act as an Access Point (AP) allowing client devices like mobile phones or tablets to connect to the network provided by the Drive. Remaining WiFi parameters [272X] will decide the properties of the provided WiFi network.
Station	1	Configure WiFi interface to connect to an existing WiFi network provided by an external Router/AP. Remaining WiFi parameters [272X] will be used to select the network to connect to and to provide the required credentials.

## Channel [2722]

Sets the WiFi channel to operate on in AccessPoint mode. Menu hidden in Station mode (will adopt to the channel used by AP/Router connected to).

**NOTE: Only channels 1-11 should be used in US.**

2722 Channel	
Default	5
0 - 13	2.4 GHz WiFi channels to be used in AccessPoint mode.

## Encryption [2723]

Selects the encryption standard to be used for the transmitted WiFi data.

2723 Encryption		
Default		WPA-2
Open	0	No encryption of the wireless link
WEP	1	WEP encryption
WPA-2	2	WPA-2 encryption

## DHCP [2724]

Selects how IP properties are handled. Static implies user give address while DHCP implies that DHCP server on network assign an IP address. In case [2721] WiFi Mode is AccessPoint, DHCP is automatically selected.

2724 DHCP		
Default		Static
Static	0	Static implies user set IP properties via menus [2727 - 2729].
DHCP	1	Server on network assign IP properties.

## SSID [2725]

First 16 chars of network name to connect to if "[2721]WiFi Mode" = Station or SSID network name to broadcast if "[2721] WiFi Mode = AccessPoint.

2725 SSID	
Default	Emotron_<5 random digits>

## Password [2726]

Password to login to router/AP when "[2721] WiFi Mode" = Station or Password for clients to use if "[2721] WiFi Mode" = AccessPoint. In case [2723] Encryption is WPA2 minimum password length is 8 characters. In case of WEP only 5 or 13 character passwords are accepted.

If incorrect length of the password is entered, the PPU displays "Invalid Pwd" message for two seconds and remains in edit mode with last entered password.

**NOTE: The password should be entered left aligned.**

Can't be read via field bus and not visible after entered.

2726 Password	
Default	12345678

**NOTE: Accepts only 32 - 126 ascii char in menus SSID [2725] and Password [2726] entry as IEEE standard speaks of 'printable ASCII characters' (in the range of 32 to 126).**

## IP Address [2727]

Shows static address to use if "[2724] DHCP" is set to Static. Shows assigned address if "[2724] DHCP" is set to DHCP. This is the IP address given to the Drive, use this address in client software to connect to the AC Drive.

2727 IP Address	
Default	192.168.1.1

## Subnet Mask [2728]

Shows static subnet mask to use if "[2724] DHCP" is set to Static. Shows assigned subnet mask if "[2724] DHCP" is set to DHCP.

2728 Subnet Mask	
Default	255.255.255.0

## Gateway [2729]

Shows assigned gateway if DHCP is selected in menu "[2724] DHCP".

2729 Gateway	
Default	192.168.1.1

## WiFi Status [272A]

Status of WiFi module is shown in this menu "[272A] WiFi Status". Status is set directly from control panel (that host the WiFi module).

272A WiFi Status		
Default		OK
OK	0	No error
Mode error	1	Initialization failure of AP/Station mode
AP pwd err	2	AP password faulty
SSID error	3	SSID length error
SecPar error	4	Security parameters or SSID supplied is wrong
Sta Disconn	5	Disconnect from router/AP in station mode
NetConf err	6	Network configuration error (IP or DHCP)
Config OK	7	If no error, this is shown 60 seconds after configuration update, then it goes back to OK.

## Bluetooth (BLE) options [273]

This menu is hidden if BLE not selected in menu "[271] WirelessMode".

### BluetoothID [2731]

Shows bluetooth device ID if connected control panel have bluetooth capability.

2731 BluetoothID	
Default	0

**NOTE:** Default is 0 or if a BLE control panel is used an eight digit unique ID used in the broadcast name.

### Paring key [2732]

Six digit numeric for the control panel BLE pairing with mobile or other BLE device.

2732 Paring Key	
Default	123456

## Security [274]

Possibility to limit access to control board (CB) registers from the wireless interfaces.

### Security mode [2741]

Sets the security mode to be used.

2741 Sec. Mode		
Default:		Open
Open	0	All requests from wireless clients should be forwarded by the control panel to control board.
Password	1	Wireless client must supply a password before access to control board registers is granted. Once access is given it will last as long as the session.

### Password [2742]

Configuration of the password to be written by the client to open up wireless access (eight (8) chars).

This menu is only shown if menu "Security mode [2741]" is set to Password (1).

2742 Password	
Default:	" " (i.e. an empty string)

**NOTE:** The password should be entered left aligned.

## 11.3 Process and Application Parameters [300]

These parameters are mainly adjusted to obtain optimum process or machine performance.

The read-out, references and actual values depends on selected process source, [321]:

Table 34

Selected process source	Unit for reference and actual value	Resolution
Speed	rpm	4 digits
Torque	%	3 digits
PT100	°C	3 digits
Frequency	Hz	3 digits

### 11.3.1 Set/View Reference Value [310]

#### View reference value

As default the menu [310] is in view operation. The value of the active reference signal is displayed. The value is displayed according to selected process source, [321] or the process unit selected in menu [322].

#### Set reference value

If the function “Reference Control [214]” is set to “Keyboard”, the reference value can be set in menu “Set/View Ref [310]” or as a motor potentiometer with the + and - keys (default) on the control panel. Selection is made with parameter Keyboard Reference Mode in menu [369]. The ramp times used when setting the reference value with MotPot function selected in [369] are according to menus “Acc MotPot [333]” and “Dec MotPot [334]”.

The ramp times used for the reference value when Normal function is selected in menu [369], are according to “Acc Time [331]” and “Dec Time [332]”.

Menu [310] displays on-line the actual reference value according to the Mode Settings in Table 34.

310 Set/View ref	
Default:	0 rpm
Dependent on:	Process Source [321] and Process Unit [322]
Speed mode	0 - max speed [343]
Torque mode	0 - max torque [351]
Other modes	Min according to menu [324] - max according to menu [325]

**NOTE: The actual value in menu [310] is not copied, or loaded from the control panel memory when Copy Set [242], Copy to CP [244] or Load from CP [245] is performed.**

---

**NOTE: If the MotPot function is used, the reference value ramp times are according to the “Acc MotPot [333]” and “Dec MotPot [334]” settings. Actual speed ramp will be limited according to “Acc Time [331]” and “Dec Time [332]”.**

---



---

**NOTE: Write access to this parameter is only allowed when menu “Ref Control [214]” is set to Keyboard. When Reference control is used, see Chapter 9. Communication, page 85.**

---

## 11.3.2 Process Settings [320]

With these functions, the AC drive can be set up to fit the application. The menus [110], [120], [310], [362]-[368] and [711] use the process unit selected in [321] and [322] for the application, e.g. rpm, bar or m<sup>3</sup>/h. This makes it possible to easily set up the AC drive for the required process requirements, as well as for copying the range of a feedback sensor to set up the Process Value Minimum and Maximum in order to establish accurate actual process information.

### Process Source [321]

Select the signal source for the process value that controls the motor. The Process Source can be set to act as a function of the process signal on AnIn F(AnIn), a function of the motor speed F(Speed), a function of the shaft torque F(Torque) or as a function of a process value from serial communication F(Bus). The right function to select depends on the characteristics and behaviour of the process. If the selection Speed, Torque or Frequency is set, the AC drive will use speed, torque or frequency as reference value.

#### Example

An axial fan is speed-controlled and there is no feedback signal available. The process needs to be controlled within fixed process values in "m<sup>3</sup>/hr" and a process read-out of the air flow is needed. The characteristic of this fan is that the air flow is linearly related to the actual speed. So by selecting F(Speed) as the Process Source, the process can easily be controlled.

The selection F(xx) indicates that a process unit and scaling is needed, set in menus [322]-[328]. This makes it possible to e.g. use pressure sensors to measure flow etc. If F(AnIn) is selected, the source is automatically connected to the AnIn which has Process Value as selected.

321 Proc Source		
Default:		Speed
F(AnIn)	0	Function of analogue input. E.g. via PID control, [380].
Speed	1	Speed as process reference <sup>1</sup> .
Torque	2	Torque as process reference <sup>2</sup> .
PT100	3	Temperature as process reference.
F(Speed)	4	Function of speed
F(Torque)	5	Function of torque <sup>2</sup>
F(Bus)	6	Function of communication reference
Frequency	7	Frequency as process reference <sup>1</sup> .
Power	9	Power as process reference <sup>2</sup>

<sup>1</sup>. Only when Drive mode [213] is set to Speed or V/Hz.

<sup>2</sup>. Only when Drive mode [213] is set to Torque.

.

**NOTE:** When PT100 is selected, use PT100 channel 1 on the PTC/PT100 option board.

**NOTE:** If Speed, Torque or Frequency is chosen in menu "[321] Proc Source", menus [321] - [328] are hidden.

**NOTE:** The motor control method depends on the selection of drive mode in menu [213], regardless of selected process source in menu [321].

**NOTE:** If F (Bus) is chosen in menu [321] see 11.5.1 Analogue Inputs [510] on page 171.

### Process Unit [322]

322 Proc Unit		
Default:		Off
Off	0	No unit selection
%	1	Percent
°C	2	Degrees Centigrade
°F	3	Degrees Fahrenheit
bar	4	Bar
Pa	5	Pascal
Nm	6	Torque
Hz	7	Frequency
rpm	8	Revolutions per minute
m <sup>3</sup> /h	9	Cubic meters per hour
gal/h	10	Gallons per hour
ft <sup>3</sup> /h	11	Cubic feet per hour
User Defined	12	User defined unit

**NOTE:** In case of conflicting setup between this Process Source [321], selection and drive mode [213] the software will automatically overrule the selection in menu [321] according to the following:

[213]=Torque and [321]=Speed => internally [321]=Torque will be used.

[213]=Speed or V/Hz and [321]=Torque => internally [321]=Speed will be used.

## User-defined Unit [323]







This menu is only displayed if User is selected in menu [322]. The function enables the user to define a unit with six symbols. Use the Prev and Next key to move the cursor to required position. Then use the + and - keys to scroll down the character list. Confirm the character by moving the cursor to the next position by pressing the Next key.

Character	No. for serial comm.	Character	No. for serial comm.
Space	0	m	58
0-9	1-10	n	59
A	11	ñ	60
B	12	o	61
C	13	ó	62
D	14	ô	63
E	15	p	64
F	16	q	65
G	17	r	66
H	18	s	67
I	19	t	68
J	20	u	69
K	21	ü	70
L	22	v	71
M	23	w	72
N	24	x	73
O	25	y	74
P	26	z	75
Q	27	å	76
R	28	ä	77
S	29	ö	78
T	30	!	79
U	31	''	80
Ü	32	#	81
V	33	\$	82
W	34	%	83
X	35	&	84
Y	36	·	85
Z	37	(	86
Å	38	)	87
Ä	39	*	88
Ö	40	+	89
a	41	,	90
á	42	-	91
b	43	.	92

Character	No. for serial comm.	Character	No. for serial comm.
c	44	/	93
d	45	:	94
e	46	;	95
é	47	<	96
ê	48	=	97
è	49	>	98
f	50	?	99
g	51	@	100
h	52	^	101
i	53	_	102
í	54	°	103
j	55	2	104
k	56	3	105
l	57		

### Example

Create a user unit named kPa.

1. When in the menu [323] press  to show the cursor.
2. Press  to move the cursor to the right most position.
3. Press  until the character a is displayed.
4. Press .
5. Then press the  until P is displayed and press .
6. Repeat until you have entered kPa, confirm with .

323 User Unit	
Default:	No characters shown

### Process Min [324]

This function sets the minimum process value allowed.

324 Process Min	
Default:	0
Range:	0.000-10000 (Speed, Torque, F(Speed), F(Torque)) -10000- +10000 (F(AnIn), PT100, F(Bus))

## Process Max [325]

This menu is not visible when speed, torque or frequency is selected. The function sets the value of the maximum process value allowed.

325 Process Max	
Default:	0
Range:	0.000-10000

## Ratio [326]

This menu is not visible when speed, frequency or torque is selected. The function sets the ratio between the actual process value and the motor speed so that it has an accurate process value when no feedback signal is used. See Fig. 108.

326 Ratio		
Default:	Linear	
Linear	0	Process is linear related to speed/torque
Quadratic	1	Process is quadratic related to speed/torque

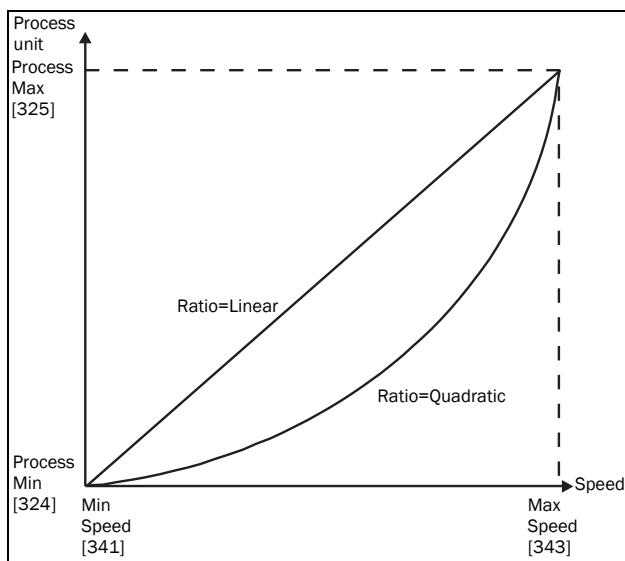

Fig. 108 Ratio.

## F(Value), Process Min [327]

This function is used for scaling if no sensor is used. It offers you the possibility of increasing the process accuracy by scaling the process values. The process values are scaled by linking them to known data in the AC drive. With “F(Value) Proc Min [327]” the precise value at which the entered “Process Min [324]” is valid can be entered.

**NOTE:** If Speed, Torque or Frequency is chosen in menu “[321] Proc Source”, menus [322]- [328] are hidden.

327 F (Val) PrMin		
Default:	Min	
Min	-1	According to Min Speed setting in [341].
Max	-2	According to Max Speed setting in [343].
0.000-10000	0-10000	0.000-10000

## F(Value), Process Max [328]

This function is used for scaling if no sensor is used. It offers you the possibility of increasing the process accuracy by scaling the process values. The process values are scaled by linking them to known data in the AC drive. With F(Value), Proc Max the precise value at which the entered "Process Max [525]" is valid can be entered.

**NOTE:** If Speed, Torque or Frequency is chosen in menu "[321] Proc Source", menus [322]- [328] are hidden.

328 F(Value) PrMax		
Default:		Max
Min	-1	Min
Max	-2	Max
0.000-10000	0-10000	0.000-10000

### Example

A conveyor belt is used to transport bottles. The required bottle speed needs to be within 10 to 100 bottles/s. Process characteristics:

10 bottles/s = 150 rpm

100 bottles/s = 1500 rpm

The amount of bottles is linearly related to the speed of the conveyor belt.

Set-up:

"Process Min [324]" = 10

"Process Max [325]" = 100

"Ratio [326]" = linear

"F(Value), ProcMin [327]" = 150

"F(Value), ProcMax [328]" = 1500

With this set-up, the process data is scaled and linked to known values which results in an accurate control.

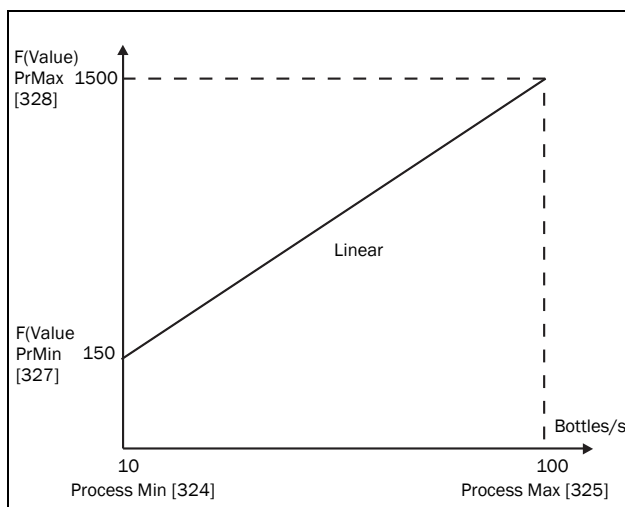

Fig. 109

## 11.3.3 Start/Stop settings [330]

Submenu with all the functions for acceleration, deceleration, starting, stopping, etc.

### Acceleration Time [331]

The acceleration time is defined as the time it takes for the motor to accelerate from 0 rpm to nominal motor speed.

**NOTE:** If the Acc Time is too short, the motor is accelerated according to the Torque Limit. The actual Acceleration Time may then be longer than the value set.

331 Acc Time	
Default:	10.0 s
Range:	0-3600 s

Fig. 110 shows the relationship between nominal motor speed/max speed and the acceleration time. The same is valid for the deceleration time.

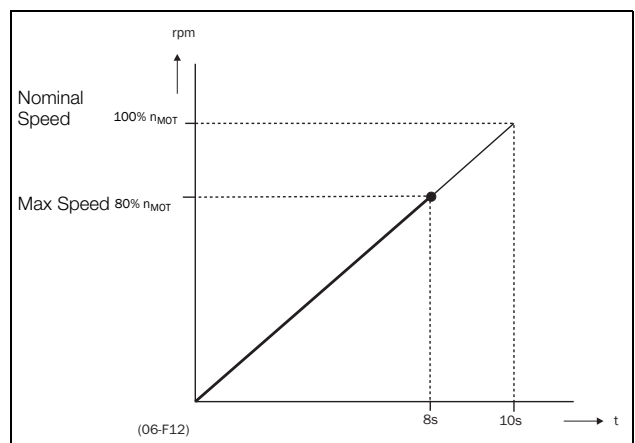

Fig. 110 Acceleration time and maximum speed.

Fig. 111 shows the settings of the acceleration and deceleration times with respect to the nominal motor speed.

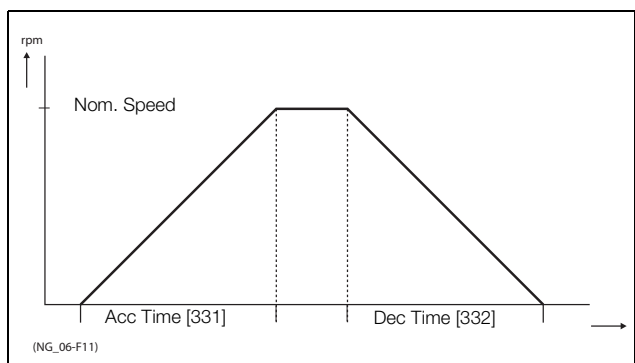

Fig. 111 Acceleration and deceleration times.

## Deceleration Time [332]

The deceleration time is defined as the time it takes for the motor to decelerate from nominal motor speed to 0 rpm.

332 Dec Time	
Default:	10.0 s
Range:	0–3600 s

**NOTE:** If the Dec Time is too short and the generator energy cannot be dissipated in a brake resistor, the motor is decelerated according to the overvoltage limit. The actual deceleration time may be longer than the value set.

## Acceleration Time Motor Potentiometer [333]

It is possible to control the speed of the AC drive using the motor potentiometer function. This function controls the speed with separate up and down commands, over remote signals. The MotPot function has separate ramps settings which can be set in “Acc MotPot [333]” and “Dec MotPot [334]”.

If the MotPot function is selected, this is the acceleration time for the MotPot up command. The acceleration time is defined as the time it takes for the motor potentiometer value to increase from 0 rpm to nominal speed.

333 Acc MotPot	
Default:	16.0 s
Range:	0.50–3600 s

## Deceleration Time Motor Potentiometer [334]

If the MotPot function is selected, this is the deceleration time for the “MotPot” down command. The deceleration time is defined as the time it takes for the motor potentiometer value to decrease from nominal speed to 0 rpm.

334 Dec MotPot	
Default:	16.0 s
Range:	0.50–3600 s

## Acceleration Time to Minimum Speed [335]

If minimum speed, [341]>0 rpm, is used in an application, the AC drive uses separate ramp times below this level. With “Acc<MinSpeed [335]” and “Dec<MinSpeed [336]” you can set the required ramp times. Short times can be used to prevent damage and excessive pump wear due to too little lubrication at lower speeds. Longer times can be used to fill up a system smoothly and prevent water hammer due to rapidly exhausting air from the pipe system.

If a Minimum speed is programmed, this parameter will be used to set the acceleration time parameter [335] for speeds up to minimum speed at a run command. The ramp time is defined as the time it takes for the motor to accelerate from 0 rpm to nominal motor speed.

335 Acc<Min Spd	
Default:	10.0 s
Range:	0-3600 s

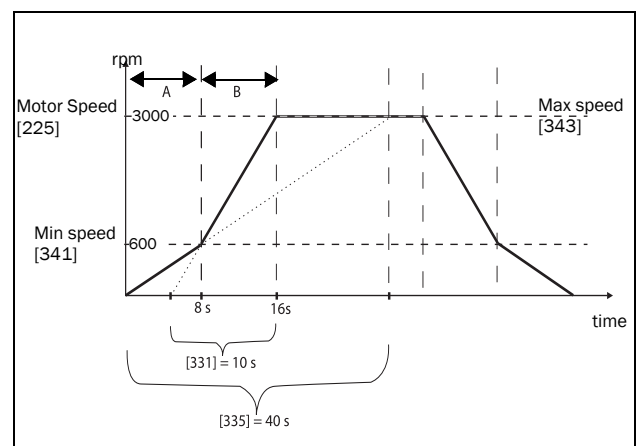

Fig. 112 Calculation example of accelerating times (graphics not proportional).

### Example

“Motor speed [225]”	3000 rpm
Minimum speed [341]	600 rpm
Maximum speed [343]	3000 rpm
Acceleration time [331]	10 seconds
Deceleration time [332]	10 seconds
Acc>Min speed[335]	40 seconds
Dec<Min speed[336]	40 seconds

- A. The drive will start from 0 rpm and accelerate to Minimum speed [341] = 600 rpm in 8 seconds according to ramp time parameter Acc>Min speed [335].  
 Calculated as following:  
 600 rpm is 20% of 3000 rpm => 20% of 40 s = 8 s.

B. The acceleration continues from minimum speed level 600 rpm to maximum speed level 3000 rpm with acceleration rate according to ramp time Acceleration time [331].

Calculate by following:

$3000 - 600 = 2400$  rpm which is 80 % of 3000 rpm => acceleration time is 80 % x 10 s = 8 s.

This means that the total acceleration time from 0 - 3000 rpm will take  $8 + 8 = 16$  seconds.

## Deceleration Time from Minimum Speed [336]

If a minimum speed is programmed, this parameter will be used to set the deceleration time from the minimum speed to 0 rpm at a stop command. The ramp time is defined as the time it takes for the motor to decelerate from the nominal motor speed to 0 rpm.

<b>336</b>	<b>Dec&lt;Min Spd</b>
Default:	10.0 s
Range:	0-3600 s

## Acceleration Ramp Type [337]

Sets the type of all the acceleration ramps in a parameter set. See Fig. 113. Depending on the acceleration and deceleration requirements for the application, the shape of both the ramps can be selected. For applications where speed changes need to be started and stopped smoothly, such as a conveyor belt with materials that can drop following a quick speed change, the ramp shape can be adapted to a S-shape and prevent speed change shocks. For applications that are not critical in this, the speed change can be fully linear over the complete range.

<b>337</b>	<b>Acc Ramp</b>
Default:	Linear
Linear	0 Linear acceleration ramp.
S-Curve	1 S-shape acceleration ramp.

**NOTE:** For S-curve ramps the ramp times, [331] and [332], defines the maximum acceleration and deceleration rates, i.e. linear part of S-curve, just as for the linear ramps. The S-curves are implemented so that for a speed step below sync speed the ramps are fully S-shaped while for larger steps the middle part will be linear. Therefore will a S-curve ramp from 0 –sync speed take 2 x Time while a step from 0–2 x sync speed will take 3 x Time (middle part 0.5sync speed – 1.5sync speed linear). Also valid for menu [338], Deceleration ramp type.

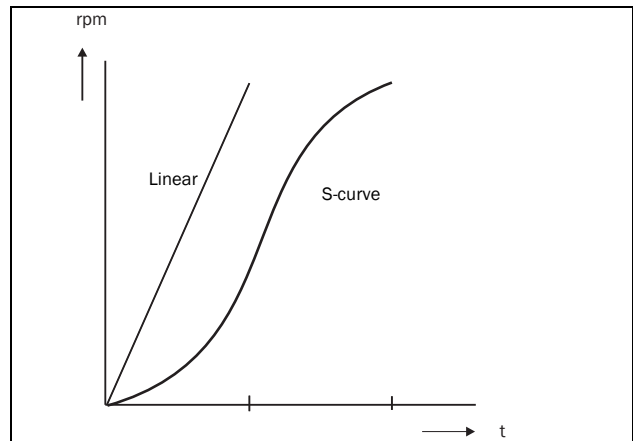

Fig. 113 Shape of acceleration ramp.

## Deceleration Ramp Type [338]

Sets the ramp type of all deceleration parameters in a parameter set Fig. 114.

<b>338</b>	<b>Dec Ramp</b>
Default:	Linear
Selection:	Same as menu [337]

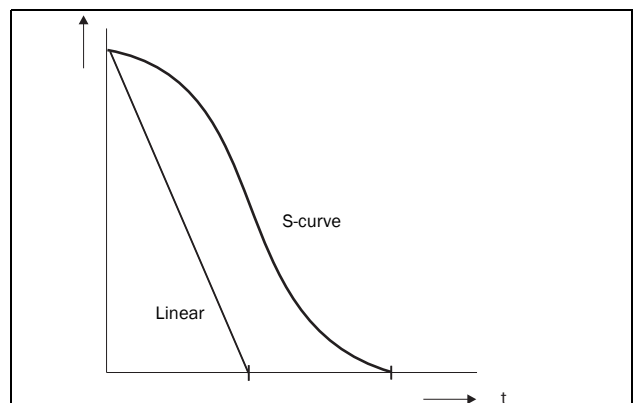

Fig. 114 Shape of deceleration ramp.

## Start Mode [339]

Sets the way of starting the motor when a run command is given.

339 Start Mode		
Default:		Normal DC
Fast	0	The motor shaft starts rotating immediately once the Run command is given. The motor flux increases gradually.
Normal DC	1	After a Run command the motor will be magnetised first and the stator resistance is measured. Depending on the motor time constant and the size of the motor it can take up to 1.3 s before the motor shaft starts to rotate. This will provide better control of the motor when starting.

## Spinstart [33A]

The spinstart will smoothly start a motor which is already rotating by catching the motor at the actual speed and control it to the desired speed. If in an application, such as an exhausting fan, the motor shaft is already rotating due to external conditions, a smooth start of the application is required to prevent excessive wear. With the spinstart=On, the actual control of the motor is delayed due to detecting the actual speed and rotation direction, which depend on motor size, running conditions of the motor before the Spinstart, inertia of the application, etc. Depending on the motor electrical time constant and the size of the motor, it can take maximum a couple of minutes before the motor is caught.

33A Spinstart		
Default:		Off
Off	0	No spinstart. If the motor is already running the AC drive can trip or will start with high current.
On	1	Spinstart will allow the start of a running motor without tripping or high inrush currents. If encoder feedback is used, both encoder speed and current signals are used to perform spinstart function.
Encoder	2	Only encoder speed used for detecting rotating machine, i.e. no rotating machine detection via initial motor current. Note: Only active if encoder is present. If no Encoder, functionality is equal to selection Off.

## Stop Mode [33B]

When the AC drive is stopped, different methods to come to a standstill can be selected in order to optimize the stop and prevent unnecessary wear. Stop Mode sets the way of stopping the motor when a Stop command is given.

33B Stop Mode		
Default:		Decel
Decel	0	The motor decelerates to 0 rpm according to the set deceleration time.
Coast	1	The motor freewheels naturally to 0 rpm.

### 11.3.4 Mechanical brake control

The four brake-related menus [33C] to [33F] can be used to control mechanical brakes e.g. to handle basic hoisting functions. When hoisting a load generally a mechanical brake holds the load when the AC drive is not running. To prevent the load from falling down a holding torque must be initiated before the mechanical brake is released. On the other hand when stopping hoisting the brake must be activated before the holding torque is removed.

Support is included for a Brake Acknowledge signal via a digital input. It is monitored using a brake fault time parameter. Additional output and trip/warning signals are also included. The acknowledge signal is either connected from the brake contactor or from a proximity switch on the brake.

The brake acknowledge signal can also be used to improve safety by preventing hoist falling load in case the brake is not engaged when stopping.

#### Brake not released - Brake Fault trip

During start and running the brake acknowledge signal is compared to the actual brake output signal and if no acknowledge, i.e. brake not released, while brake output is high for the Brake Fault time [33H], then a Brake trip is generated.

#### Brake not engaged - Brake Warning and continued operation (keep torque)

The brake acknowledge signal is compared to the actual brake output signal at stop. If acknowledge is still active, i.e. brake not engaged, while brake output is low for the Brake Engage time [33E] then a Brake warning is generated and the torque is kept, i.e. prolonging normal brake engage mode, until brake closes or an emergency action is needed by the operator, such as setting down the load.

### Brake Release Time [33C]

The Brake Release Time sets the time the AC drive delays before ramping up to whatever final reference value is selected. During this time a predefined speed can be generated to hold the load where after the mechanical brake finally releases. This speed can be selected at Release Speed, [33D]. Immediate after the brake release time expiration the brake lift signal is set. The user can set a digital output or relay to the function Brake. This output or relay can control the mechanical brake.

33C Brk Release	
Default:	0.00 s
Range:	0.00–3.00 s

Fig. 115 shows the relation between the four Brake functions.

- Brake Release Time [33C]
- Release Speed [33D]
- Brake Engage Time [33E]
- Brake Wait Time [33F]

The correct time setting depends on the maximum load and the properties of the mechanical brake. During the brake release time it is possible to apply extra holding torque by setting a release speed reference with the function release speed [33D].

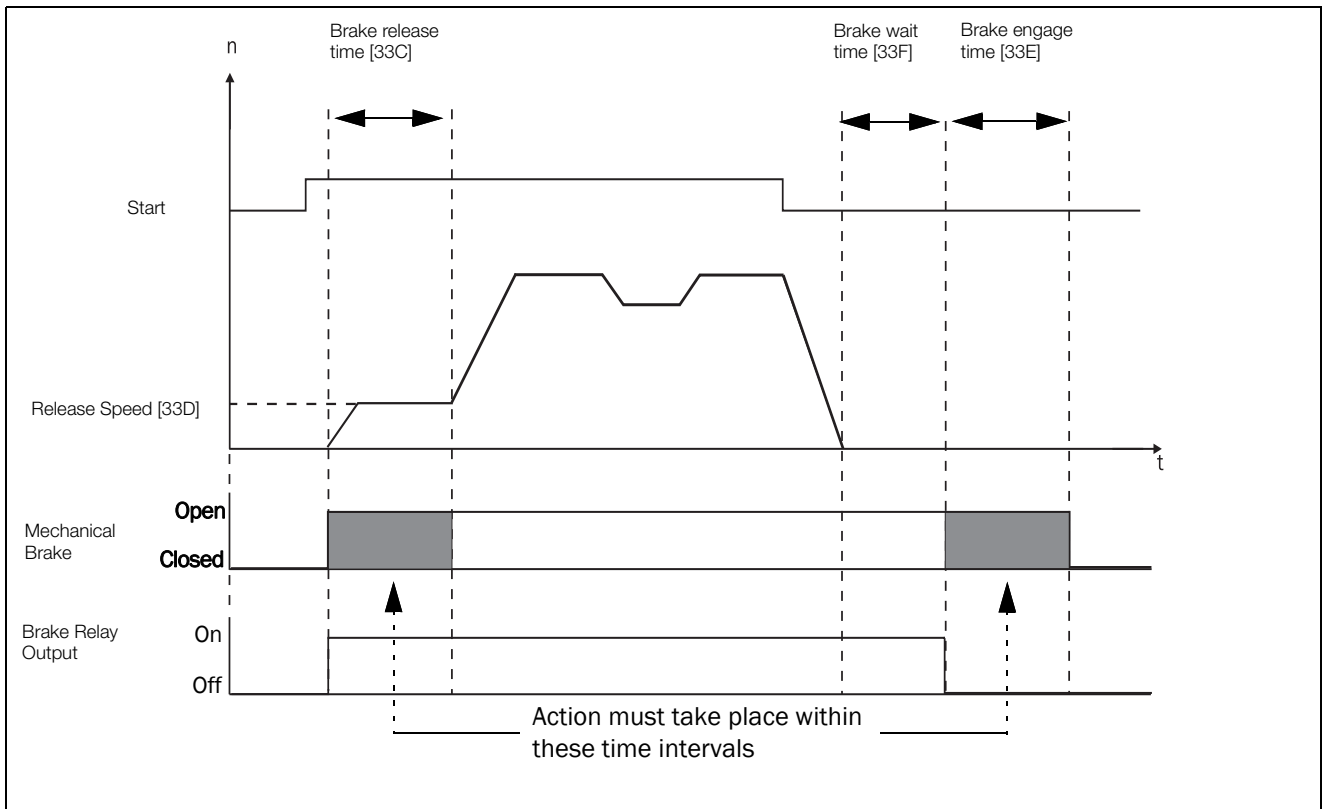

Fig. 115 Brake Output functions.

**NOTE:** Although this function is designed to operate a mechanical brake via the digital outputs or relays (set to brake function) controlling a mechanical brake, it can also be used without a mechanical brake and hold the load in a fixed position.

## Release Speed [33D]

The release speed only operates with the brake function: brake release [33C]. The release speed is the initial speed reference during the brake release time. The torque reference is initialized to 90% of  $T_{NOM}$  to ensure that the load is held in place.

33D Release Spd	
Default:	0 rpm
Range:	- 4x Sync. Speed to 4x Sync.
Depend on:	4x motor sync speed, 1500 rpm for 1470 rpm motor.

**NOTE:** Speed signal is limited to < 32767.

## Brake Engage Time [33E]

The brake engage time is the time the load is held while the mechanical brake engages. It is also used to get a firm stop when transmissions, etc. cause “whiplash” effects. In other words, it compensates for the time it takes to engage a mechanical brake.

33E Brk Engage	
Default:	0.00 s
Range:	0.00–3.00 s

## Wait Before Brake Time [33F]

The brake wait time is the time to keep brake open and to hold the load, either in order to be able to speed up immediately, or to stop and engage the brake.

33F Brk Wait	
Default:	0.00 s
Range:	0.00–30.0 s

## Vector Brake [33G]

Braking by increasing the internal electrical losses in the motor.

33G Vector Brake		
Default:	Off	
Off	0	Vector brake switched off. AC drive brakes normal with voltage limit on the DC link.
On	1	Maximum AC drive current ( $I_{CL}$ ) is available for braking.

## Brake Fault trip time [33H]

The “Brake Fault trip time” for “Brake not released” function is specified in this menu.

33H Brk Fault	
Default:	1.00s
Range	0.00 - 5.00s

**Note:** The Brake Fault trip time should be set to longer time than the Brake release time[33C].

The “Brake not engaged” warning is using the setting of parameter “Brake Engaged time [33E]”. Fig. 116 shows principle of brake operation for fault during run (left) and during stop (right).

## Release torque [33I]

The Brake Release Time [33C] sets the time the AC drive delays before ramping up to whatever final speed reference value is selected, to allow the brake to be fully opened. During this time a holding torque to prevent roll-back of the load can be activated. The parameter Release Torque [33I] is used for this purpose.

The release torque initiates the torque reference from the speed controller during the Brake Release Time [33C]. The release torque defines a minimum level of release (holding) torque. The set release torque is internally overruled if the actual required holding torque measured at the previous closing of brake is higher. The release torque is set with sign in order to define the holding torque direction.

33I Release Trq	
Default:	0%
Range	-400% to 400%

**Note!** Function is deactivated if set to 0%.

**Note!** Release Torque [33I] has priority over torque reference initialization by Release Speed [33D].

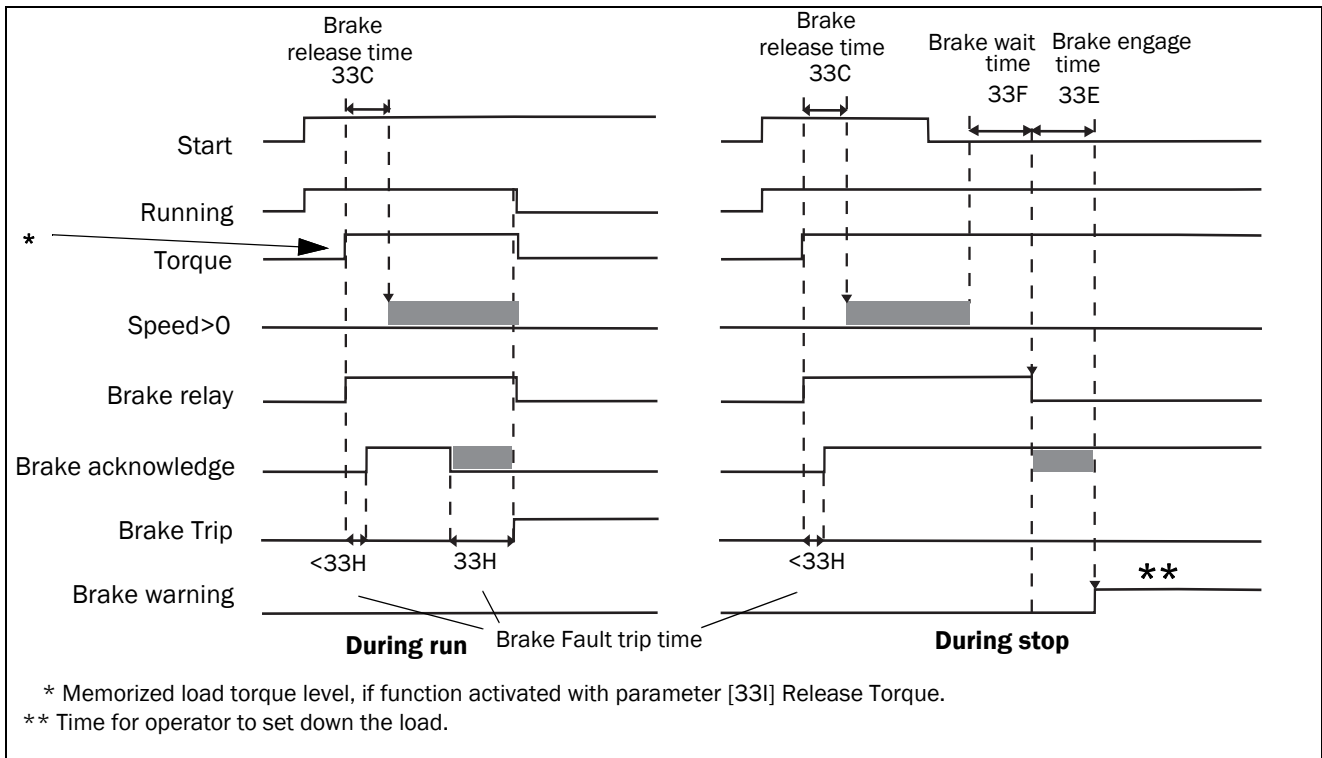

Fig. 116 Principle of Brake operation for fault during run and during stop.

### DC Hold [33J]

This function enables applying a DC voltage to the motor at zero speed. This provides a (low) holding torque. This function is available for all non-torque drive modes.

#### DC Hold [33J1]

Enabling of DC hold functionality.

33J1 DC Hold	
Default:	Off
Off	0
On	1

#### DC Holding Speed [33J2]

Select the speed at which DC hold is released / enabled. DC hold is activated if both the speed and the speed reference is below this value.

33J2 DC Hold Spd	
Default:	10rpm
Range:	0 - 250 rpm

### DC Holding Current [33J3]

Select the applied DC hold current in percent of nominal motor current.

33J3 DC Hold Cur	
Default:	30 %
Range:	0 - 100 %

### Start Vector [33K]

Select the voltage vector applied at start. The start vector is normally in the direction of the U-phase. It is also possible to sequentially select different start vectors each start. This can be advantageous as it distributes the wear more evenly between different IGBTs. In particular if DC-start is used. The start vector may also be selected based on the encoder position (when applicable).

33K Start Vector	
Default:	Normal (U)
Normal (U)	0 U-phase
Sequence	1 Sequentially select different vectors
Encoder	2 Based on encoder position

### 11.3.5 Speed [340]

Menu with all parameters for settings regarding to speeds, such as Min/Max speeds, Jog speeds, Skip speeds.

#### Minimum Speed [341]

Sets the minimum speed. The minimum speed will operate as an absolute lower limit. Used to ensure the motor does not run below a certain speed and to maintain a certain performance.

341 Min Speed	
Default:	0 rpm
Range:	0 - Max Speed
Dependent on:	Set/View ref [310]

**NOTE: A lower speed value than the set minimum speed can be shown in the display due to motor slip.**

#### Stop/Sleep when less than Minimum Speed [342]

With this function it is possible to put the AC drive in “sleep mode” when it is running at minimum speed for the length of time set in menu “Stp<MinSpd [342]”. The AC drive will go into sleep mode after programmed time.

When the reference signal or PID Process controller output value (if PID Process controller is used) raises the required speed value above the min speed value, the AC drive will automatically wake up and ramp up to the required speed.

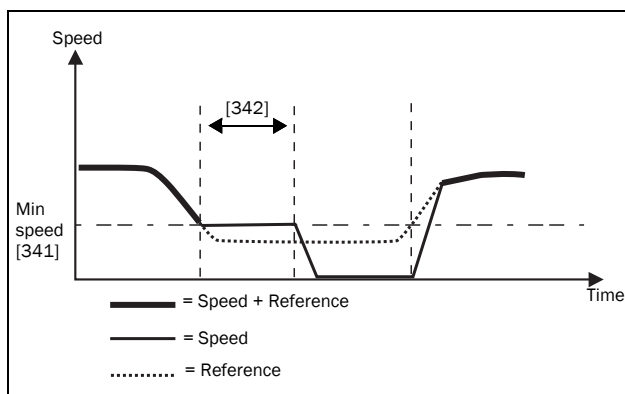

Fig. 117

If you want to use this function when having “process reference” signal via an analogue input, you need to make sure that the concerning analogue input is set up correct, meaning that AnIn Advanced parameter "AnIn1 FcMin [5134]" should be set from "Min" (=default) to "User defined" and “AnIn1 VaMin[5135]” set to a value less than “Min Speed [341]” to make it possible that the analogue input reference can go below the "Min Speed" level to activate the “Sleep mode”. This applies when PID Process controller is not used.

**NOTE: If [381] PID Process controller is used, then the PID sleep functionality [386] - [389] is recommended instead of [342]. See further page 151.**

**NOTE: Menu [386] has higher priority than menu [342].**

342 Stp<MinSpd	
Default:	Off
Range:	Off, 1–3600 s (Off=0)

#### Maximum Speed [343]

Sets the maximum speed. The maximum speed will operate as an absolute maximum limit. This parameter is used to prevent damage due to high speed.

The synchronous speed (Sync-spd) is determined by the parameter motor speed [225].

343 Max Speed		
Default:		Sync Speed
Sync Speed	0	Synchronous speed, i.e. no load speed, at nominal frequency.
1-35940rpm	1- 35940	Min Speed - 4 x Motor Sync Speed

**NOTE: It is not possible to set the maximum speed lower than the minimum speed.**

**Note: Maximum speed [343] has priority over Min Speed [341], i.e. if [343] is set below [341] then the drive will run at [343] Max Speed with acceleration times given by [335] and [336] respectively.**

## Skip Speed 1 Low [344]

Within the Skip Speed range High to Low, the speed cannot be constant in order to avoid mechanical resonance in the AC drive system.

When Skip Speed Low  $\leq$  Ref Speed  $\leq$  Skip Speed High, then Output Speed=Skip Speed HI during deceleration and Output Speed=Skip Speed LO during acceleration. Fig. 118 shows the function of skip speed hi and low.

Between Skip Speed HI and LO, the speed changes with the set acceleration and deceleration times. Skipspd1 LO sets the lower value for the 1st skip range.

344 SkipSpd 1 Lo	
Default:	0 rpm
Range:	0 - 4 x Motor Sync Speed

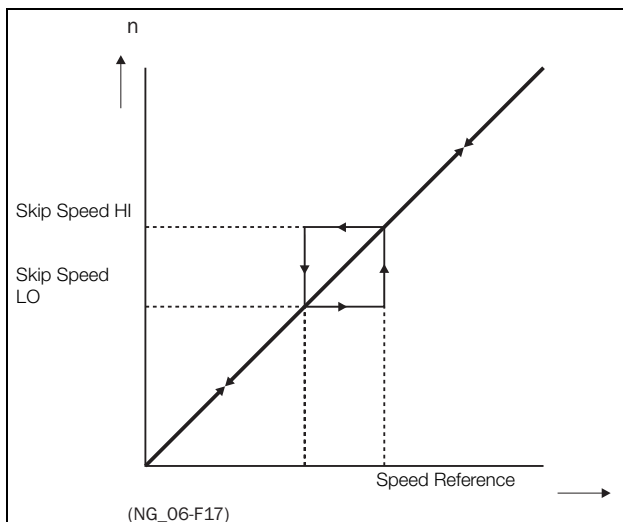

Fig. 118 Skip Speed.

**NOTE:** The two Skip Speed ranges may be overlapped.

## Skip Speed 1 High [345]

Skipspd1 HI sets the higher value for the 1st skip range.

345 SkipSpd 1 Hi	
Default:	0 rpm
Range:	0 - 4 x Sync Speed

## Skip Speed 2 Low [346]

The same function as menu [344] for the 2nd skip range.

346 SkipSpd 2 Lo	
Default:	0 rpm
Range:	0 - 4 x Motor Sync Speed

## Skip Speed 2 High [347]

The same function as menu [345] for the 2nd skip range.

347 SkipSpd 2 Hi	
Default:	0 rpm
Range:	0 - 4 x Motor Sync Speed

## Jog Speed [348]

The Jog Speed function is activated by one of the digital inputs. The digital input must be set to the Jog function [520]. The Jog command/function will automatically generate a run command as long as the Jog command/function is active. This is valid independent of settings in menu [215]. The rotation is determined by the polarity of the set Jog Speed.

### Example

If Jog Speed = -10, this will give a Run Left command at 10 rpm regardless of RunL or RunR commands. Fig. 119 shows the function of the Jog command/function.

348 Jog Speed	
Default:	50 rpm
Range:	-4 x motor sync speed to +4 x motor sync speed
Dependent on:	Defined motor sync speed. Max = 400%, normally max=AC drive $I_{max}$ /motor $I_{nom}$ x 100%.

**NOTE:** Speed signal is limited to < 32767.

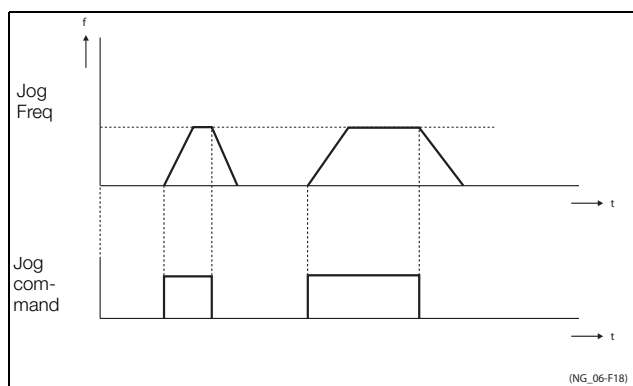

Fig. 119 Jog command.

## Droop Speed [349]

Speed drooping reduces the speed in proportion to the torque. This can be used for stationary load sharing between motors connected to the same load. The droop speed is the requested speed reduction at nominal torque. The droop speed is expressed in percent of nominal speed. The value needs to be tuned to the application. A good starting value is 5%. The ramp times in [33x] impact the dynamic behavior.

Speed [rpm] = Speed Ref [rpm] - Droop Speed [%] / 100 \* Torque [%] / 100 \* Nominal Speed [rpm].

349 Droop Speed	
Default:	0% (means function is turned off)
Range:	0 - 20%

## Over Speed Trip [34A]

The over speed trip level is configurable in percentage of the maximum speed set in menu [343].

34A OverSpdTrip	
Default:	110%
Range:	Off, 1-150% (Off =0)

## 11.3.6 Torques [350]

Menu with all parameters for torque settings.

### Maximum Torque [351]

Sets the maximum motor torque (according to menu group “Motor Data [220]”). This Maximum Torque operates as an upper torque limit. A Speed Reference is always necessary to run the motor.

$$T_{MOT}(Nm) = \frac{P_{MOT}(kw) \times 9550}{n_{MOT}(rpm)} = 100\%$$

351 Max Torque	
Default:	120% calculated from the motor data
Range:	0-400%

**NOTE:** The Max Torque parameter will limit the maximum output current of the AC drive following the relation: 100% Tmot corresponds to 100% Imot. The maximum possible setting for parameter 351 is limited by Inom/Imot x 120%, but not higher than 400%.

**NOTE:** The motor temperature increases very quickly due to extensive power losses.

### IxR Compensation [352]

This function compensates for the drop in voltage over different resistances such as (very) long motor cables, chokes and motor stator by increasing the output voltage at a constant frequency. IxR Compensation is most important at low frequencies and is used to obtain a higher starting torque. The maximum voltage increase is 25% of the nominal output voltage. See Fig. 120.

Selecting “Automatic” will use the optimal value according to the internal model of motor. “User-Defined” can be selected when the start conditions of the application do not change and a high starting torque is always required. A fixed IxR Compensation value can be set in the menu [353].

**NOTE:** This menu is visible only in V/Hz mode.

352 IxR Comp		
Default:		Off
Off	0	Function disabled
Automatic	1	Automatic compensation
User Defined	2	User defined value in percent.

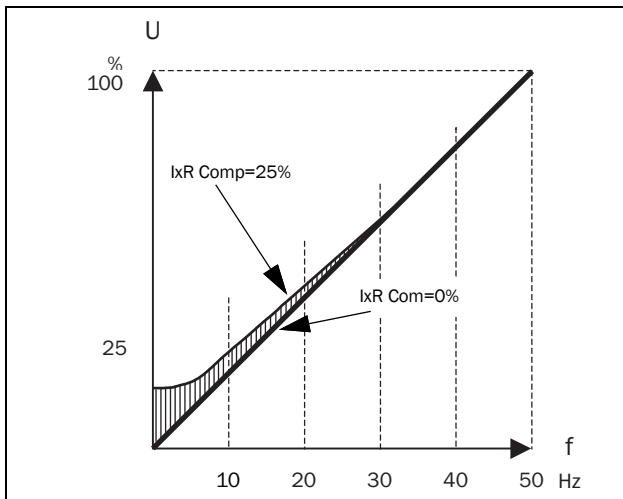

Fig. 120 IxR Comp at Linear V/Hz curve.

### IxR Comp user [353]

Only visible if User-Defined is selected in previous menu.

353 IxR CompUsr	
Default:	0.0%
Range:	0-25% x U <sub>NOM</sub> (0.1% of resolution)

**NOTE:** A too high level of IxR Compensation could cause motor saturation. This can cause a “Power Fault” trip. The effect of IxR Compensation is stronger with higher power motors.

**NOTE:** The motor may be overheated at low speed. Therefore it is important that the Motor I<sup>2</sup>t Current [232] is set correctly.

### Flux Optimization [354]

#### Asynchronous motors

Flux Optimization for asynchronous motors reduces the energy consumption and the motor noise, at low or no load conditions. Flux Optimization automatically decreases the V/Hz ratio, depending on the actual load of the motor when the process is in a steady state. Fig. 121 shows the area within which the Flux Optimization is active.

#### Permanent magnet synchronous and synchronous reluctance motors

Flux optimization for permanent magnet synchronous motors and synchronous reluctance motors adjusts the V/Hz ratio, to either minimize the current or by predicting a suitable level based on the torque (and speed). Note that

IxR compensation is needed for synchronous motors to get a good start, also when flux optimization is activated.

354 Flux optim		
Default:	Off	
Off	0	Function disabled
On (I <sub>min</sub> )	1	Flux controlled to minimize current
On (n, T)	2	Flux adjusted based on the torque
On (cosφ)	3	Flux controlled to minimize reactive power.

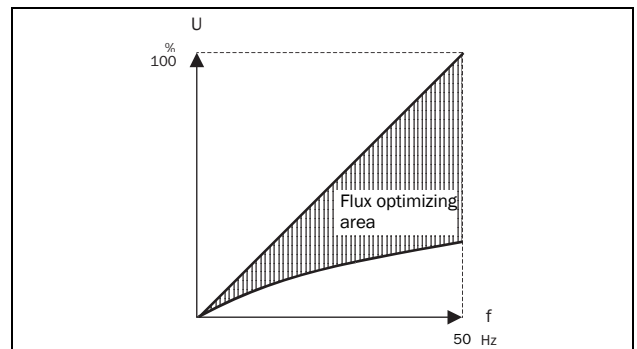

Fig. 121 Flux Optimizing

**NOTE:** Flux optimization works best at stable situations in slow changing processes.

### Maximum power [355]

Sets maximum power. Can be used for limiting motor power in field weakening operation. This function operates as an upper power limit and internally limits the parameter “Max Torque [351]” according to:  
 $T_{limit} = P_{limit}[\%] / (\text{Actual Speed} / \text{Sync Speed})$

“Off” means no power limit.

355 Max Power	
Default:	Off
Range:	Off, 1 - 400% of motor nominal power (Off=0)

**NOTE:** The maximum possible setting for parameter [355] is limited by  $I_{NOM}/I_{MOT} \times 120\%$ , but not higher than 400%.

## Torque Ramp [356]

**NOTE:** This menu is only valid for VFX drives.

Torque ramp time when using the Speed PI controller. This provides a smoother torque response.

356 Torque Ramp	
Default:	Off
Range:	0.01 s - 30.00 s (Off=0.00 s)

## Torque Limitation Trip Time [357]

Enables and sets the time for a torque limitation trip. Both user configurable limitations (e.g. max torque and max power) and protective functions (e.g. voltage limitation) can limit the torque. Torque drive modes disable this function.

357 TL Trip	
Default:	Off
Range:	Off, 0.1-6553.5s (Off=0))

## 11.3.7 Preset References [360]

### Motor Potentiometer [361]

Sets the properties of the motor potentiometer function. See the parameter “DigIn1 [521]” for the selection of the motor potentiometer function.

361 Motor Pot		
Default:	Non Volatile	
Volatile	0	After a stop, trip or power down, the AC drive will start always from zero speed (or minimum speed, if selected).
Non volatile	1	Non Volatile. After a stop, trip or power down of the AC drive, the reference value at the moment of the stop will be memorized. After a new start command the output speed will resume to this saved value.

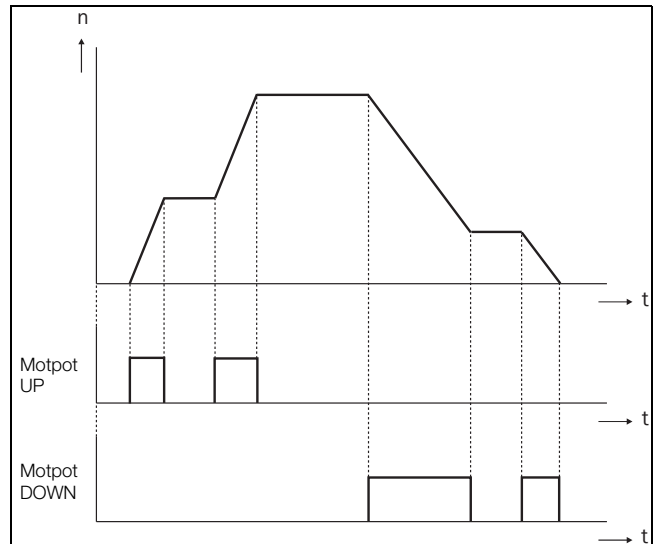

Fig. 122 MotPot function.

## Preset Ref 1 [362] to Preset Ref 7 [368]

Preset speeds have priority over the analogue inputs. Preset speeds are activated by the digital inputs. The digital inputs must be set to the function Pres. Ref 1, Pres. Ref 2 or Pres. Ref 4.

Depending on the number of digital inputs used, up to 7 preset speeds can be activated per parameter set. Using all the parameter sets, up to 28 preset speeds are possible.

362 Preset Ref 1	
Default:	Speed, 0 rpm
Dependent on:	Process Source [321] and Process Unit [322]
Speed mode	0 - max speed [343]
Torque mode	0 - max torque [351]
Other modes	Min according to menu [324] - max according to menu [325]

The same settings are valid for the menus:

“[363] Preset Ref 2”, with default 250 rpm  
 “[364] Preset Ref 3”, with default 500 rpm  
 “[365] Preset Ref 4”, with default 750 rpm  
 “[366] Preset Ref 5”, with default 1000 rpm  
 “[367] Preset Ref 6”, with default 1250 rpm  
 “[368] Preset Ref 7”, with default 1500 rpm

The selection of the presets is as in Table 35.

Table 35

Preset Ctrl3	Preset Ctrl2	Preset Ctrl1	Output Speed
0	0	0	Analogue reference
0	0	1 <sup>1)</sup>	Preset Ref 1
0	1 <sup>1)</sup>	0	Preset Ref 2
0	1	1	Preset Ref 3
1 <sup>1)</sup>	0	0	Preset Ref 4
1	0	1	Preset Ref 5
1	1	0	Preset Ref 6
1	1	1	Preset Ref 7

<sup>1)</sup> = selected if only one preset reference is active

1 = active input

0 = non active input

**NOTE: If only Preset Ctrl3 is active, then the Preset Ref 4 can be selected. If Presets Ctrl2 and 3 are active, then the Preset Ref 2, 4 and 6 can be selected.**

## Keyboard reference mode [369]

This parameter sets how the reference value [310] is edited.

369 Key Ref Mode		
Default:	MotPot	
Normal	0	The reference value is edited as a normal parameter (the new reference value is activated when Enter is pressed after the value has been changed). The “Acc Time [331]” and “Dec Time [332]” are used.
MotPot	1	The reference value is edited using the motor potentiometer function (the new reference value is activated directly when the key + or - is pressed). The “Acc MotPot [333]” and “Dec MotPot [334]” are used.
MotPot+	2	This selection makes it possible to update the reference in “[310]” directly from the [100]-menu. Pressing +/- in the [100]-menu changes the menu to [310] and there you can continue to press +/- to update the reference. When no key has been pressed for a second the menu returns to [100] automatically.

**NOTE: When Key Ref Mode is set to MotPot, the reference value ramp times are according to the “Acc MotPot [333]” and “Dec MotPot [334]” settings. Actual speed ramp will be limited according to “Acc Time [331]” and “Dec Time [332]”.**

### 11.3.8 PI Speed Control [370]

The AC drive has an internal speed controller, which is used to keep the shaft speed equal to the set speed reference. This internal speed controller works without an external feedback.

With the parameters speed P gain [372] and speed I time [373] the controller can be optimized manually.

### Speed PI Autotune [371]

The function speed autotune will perform a torque step change, and measures the reaction on shaft speed.

It automatically sets the internal speed I time to its optimum value. The speed PI autotune must be done during operation with the motor load connected and the motor running. "Autotune" will be flashing in the display during the autotune operation. When the test is successfully concluded, the display will show "Autotune OK!" for 3 s.

371 Spd PI Auto	
Default:	Off
Off	0
On	1

**NOTE:** Run the autotune at speed lower than 80% of the nominal motor speed. Otherwise autotune will fail.

**NOTE:** RUN command must be activated manually via Keyboard button.

**NOTE:** The setting will automatically return to Off when the autotuning is finished.

**NOTE:** This menu is only visible if AC drive Mode = Speed or V/Hz.

### Speed P Gain [372]

For adjusting the P gain of the internal speed controller. The speed P gain must be manually tuned for a faster reaction to load changes. The speed P gain can be increased until there is audible noise from the motor and then decreased until the noise disappears.

372 Spd P Gain	
Default:	See note
Range:	0.0–60.0

### Speed I Time [373]

To adjust the time of the internal speed controller see parameter Speed PI Autotune [371].

373 Spd I Time	
Default:	See note
Range:	0.05–100 s

**NOTE:** The default settings are calculated for a standard 4-pole motor without load according to the nominal power of the AC drive.

### 11.3.9 PID Process Control [380]

The PID controller is used to control an external process via a feedback signal. The reference value can be set via analogue input AnIn1, at the Control Panel [310] by using a Preset Reference, or via serial communication. The feedback signal (actual value) must be connected to an analogue input that is set to the function Process Value.

#### Process PID Control [381]

This function enables the PID controller and defines the response to a changed feedback signal.

381 PID Control		
Default:	Off	
Off	0	PID control deactivated.
On	1	The speed increases when the feedback value decreases. PID settings according to menus [381] to [385].
Invert	2	The speed decreases when the feedback value decreases. PID settings according to menus [383] to [385].

#### PID P Gain [383]

Setting the P gain for the PID controller.

383 PID P Gain	
Default:	1.0
Range:	0.0–30.0

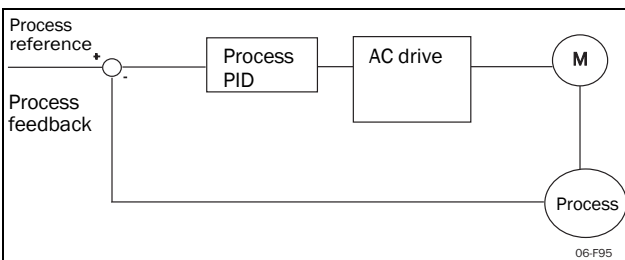

Fig. 123 Closed loop PID control.

#### PID I Time [384]

Setting the integration time for the PID controller.

384 PID I Time	
Default:	1.00 s
Range:	0.01–300 s

#### Process PID D Time [385]

Setting the differentiation time for the PID controller.

385 PID D Time	
Default:	0.00 s
Range:	0.00–30 s

#### PID sleep functionality

This function is controlled via a wait delay and a separate wake-up margin condition. With this function it is possible to put the AC drive in “sleep mode” when the process value is at its set point and the motor is running at minimum speed for the length of the time set in [386]. By going into sleep mode, the by the application consumed energy is reduced to a minimum. When the process feedback value goes below the set margin on the process reference as set in [387], the AC drive will wake up automatically and normal PID operation continues, see examples.

**NOTE:** When the drive is in Sleep mode, this is indicated with “slp” in the lower left corner of the display.

#### PID sleep when less than minimum speed [386]

If the PID output is equal to or less than minimum speed for given delay time, the AC drive will go to sleep.

386 PID<MinSpd	
Default:	Off
Range:	Off, 0.01 –3600 s (Off=0)

**NOTE:** Menu [386] has higher priority than menu [342].

## PID Activation Margin [387]

The PID activation (wake-up) margin is related to the process reference and sets the limit when the AC drive should wake-up/start again.

387 PID Act Marg	
Default:	0
Range:	0 –10000 in Process unit

**NOTE:** The margin is always a positive value.

### Example 1 PID control = normal (flow or pressure control)

[321] = F (AnIn)  
 [322] = Bar  
 [310] = 20 Bar  
 [342] = 2 s (inactive since [386] is activated and have higher priority)  
 [381] = On  
 [386] = 10 s  
 [387] = 1 Bar

The AC drive will stop/sleep when the speed (PID output) is below or equal to Min Speed for 10 seconds. The AC drive will activate/wake up when the “Process value” goes below the PID Activation Margin which is related to the process reference, i.e. goes below (20-1) Bar. See Fig. 124.

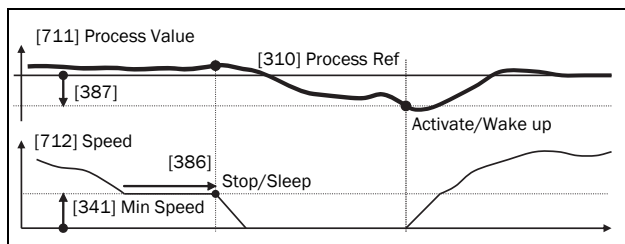

Fig. 124 PID Stop/sleep with normal PID.

### Example 2 PID control = inverted (tank level control)

[321] = F (AnIn)  
 [322] = m  
 [310] = 7 m  
 [342] = 2 s (inactive since [386] is activated and have higher priority)  
 [381] = Inverted  
 [386] = 30 s  
 [387] = 1 m

The AC drive will stop/sleep when the speed (PID output) is below or equal to Min Speed for 30 seconds. The AC drive will activate/wake up when the “Process value” goes above the PID Activation Margin which is related to the process reference, i.e. goes above (7+1) m. See Fig. 125.

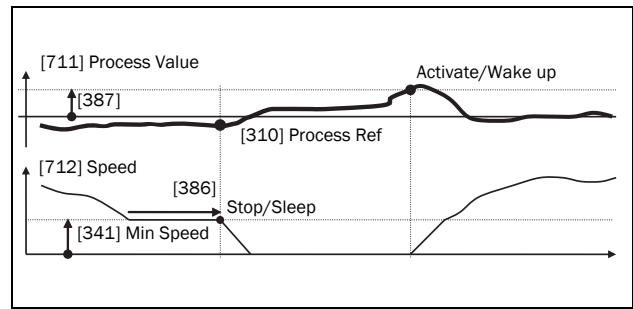

Fig. 125 PID Stop/sleep with inverted PID.

## PID Steady State Test [388]

In application situations where the feedback can become independent of the motor speed, this PID Steady Test function can be used to overrule the PID operation and force the AC drive to go in sleep mode i.e. the AC drive automatically reduces the output speed while at the same time ensures the process value.

Example: pressure controlled pump systems with low/no flow operation and where the process pressure has become independent of the pump speed, e.g. due to slowly closed valves. By going into Sleep mode, heating of the pump and motor will be avoided and no energy is spilled.

PID Steady state test delay.

**NOTE:** It is important that the system has reached a stable situation before the Steady State Test is initiated.

388 PID Stdy Tst	
Default:	Off
Range:	Off, 0.01–3600 s (Off=0)

## PID Steady State Margin [389]

PID steady state margin defines a margin band around the reference that defines “steady state operation”. During the steady state test the PID operation is overruled and the AC drive is decreasing the speed as long as the PID error is within the steady state margin. If the PID error goes outside the steady state margin the test failed and normal PID operation continues, see example.

389 PID Stdy Mar	
Default:	0
Range:	0–10000 in process unit

Example: The PID Steady Test starts when the process value [711] is within the margin and Steady State Test Wait Delay has expired. The PID output will decrease speed with a step value which corresponds to the margin as long as the Process value [711] stays within steady state margin. When Min Speed [341] is reached the steady state test was successful and stop/sleep is commanded if PID sleep function [386] and [387] is activated. If the Process value [711] goes

outside the set steady state margins then the test failed and normal PID operation will continue, see Fig. 126.

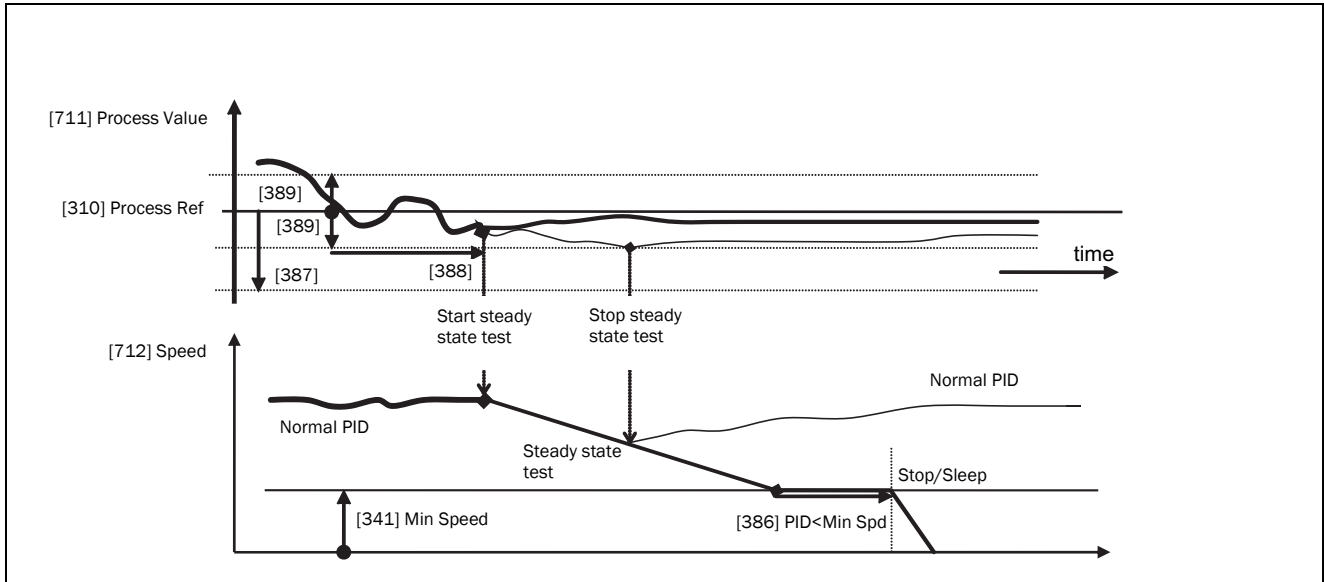

Fig. 126 Steady state test.

## 11.3.10 Emotron Dedicated Pump 390

<b>390</b>	<b>EmoDedicPump</b>
------------	---------------------

### Pump/Fan Control [391]

The Pump Control functions are in menu [391]. The function is used to control a number of drives (pumps, fans, etc.) of which one is always driven by the AC drive.

#### Pump enable [3911]

This function will enable the pump control to set all relevant pump control functions.

<b>3911</b>	<b>Pump enable</b>	
Default:	Off	
Off	0	Pump control is switched off.
On	1	Pump control is on: <ul style="list-style-type: none"> <li>- Pump control parameters [3912] to [391G] appear and are activated according to default settings.</li> <li>- View functions [391H] to [391M] are added in the menu structure.</li> </ul>

#### Number of Drives [3912]

Sets the total number of drives which are used, including the Master AC drive. The setting here depends on the parameter "Select Drive [3913]". After the number of drives is chosen it is important to set the relays for the pump control. If the digital inputs are also used for status feedback, these must be set for the pump control according to; Pump 1 OK– Pump6 OK in menu [520].

<b>3912</b>	<b>No of Drives</b>	
Default:	2	
1-3	Number of drives if I/O Board is not used.	
1-6	Number of drives if 'Alternating MASTER' is used, see Select Drive [3913]. (I/O Board is used.)	
1-7	Number of drives if 'Fixed MASTER' is used, see Select Drive [3913]. (I/O Board is used.)	

**NOTE: Used relays must be defined as Slave Pump or Master Pump. Used digital inputs must be defined as Pump Feedback.**

### Select Drive [3913]

Sets the main operation of the pump system. 'Sequence' and 'Runtime' are Fixed MASTER operation. 'All' means Alternating MASTER operation.

<b>3913</b>	<b>Select Drive</b>	
Default:	Sequence	
Sequence	0	Fixed MASTER operation: <ul style="list-style-type: none"> <li>- The additional drives will be selected in sequence, i.e. first pump 1 then pump 2 etc.</li> <li>- A maximum of 7 drives can be used.</li> </ul>
Run Time	1	Fixed MASTER operation: <ul style="list-style-type: none"> <li>- The additional drives will be selected depending on the Run Time. So the drive with the lowest Run Time will be selected first. The Run Time is monitored in menus [391H] to [391M] in sequence. For each drive the Run Time can be reset.</li> <li>- When drives are stopped, the drive with the longest Run Time will be stopped first.</li> <li>- Maximum 7 drives can be used.</li> </ul>
All	2	Alternating MASTER operation: <ul style="list-style-type: none"> <li>- When the drive is powered up, one drive is selected as the Master drive. The selection criteria depends on the Change Condition [3914]. The drive will be selected according to the Run Time. So the drive with the lowest Run Time will be selected first. The Run Time is monitored in menus [391H] to [391M] in sequence. For each drive the Run Time can be reset.</li> <li>- A maximum of 6 drives can be used.</li> </ul>

**NOTE: This menu will NOT be active if only one drive is selected.**

## Change Condition [3914]

This parameter determines the criteria for changing the master. This menu only appears if Alternating MASTER operation is selected. The elapsed run time of each drive is monitored. The elapsed run time always determines which drive will be the 'new' master drive.

This function is only active if the parameter "Select Drive [3913]" = "All" is used

3914		Change Cond
Default:		Both
Stop	0	The Runtime of the master drive determines when a master drive has to be changed. The change will only take place after a: - Power Up - Stop - Standby condition - Trip condition.
Timer	1	The master drive will be changed if the timer setting in Change Timer [3915] has elapsed. The change will take place immediately. So during operation the additional pumps will be stopped temporarily, the 'new' master will be selected according to the Run Time and the additional pumps will be started again. It is possible to leave 2 pumps running during the change operation. This can be set with Drives on Change [3916].
Both	2	The master drive will be changed if the timer setting in Change Timer [3915] has elapsed. The 'new' master will be selected according to the elapsed Run Time. The change will only take place after a: - Power Up - Stop - Standby condition. - Trip condition.

**NOTE:** If the Status feedback inputs (DigIn 9 to DigIn 14) are used, the master drive will be changed immediately if the feedback generates an 'Error'.

## Change Timer [3915]

When the time set here is elapsed, the master drive will be changed. This function is only active if "Select Drive [3913]" = All and "Change Cond [3914]" = Timer/ Both.

3915		Change Timer
Default:		50 h
Range:		1-3000 h

## Drives on Change [3916]

If a master drive is changed according to the timer function (Change Condition=Timer/Both [3914]), it is possible to leave additional pumps running during the change operation. With this function the change operation will be as smooth as possible. The maximum number to be programmed in this menu depends on the number of additional drives.

### Example

If the number of drives is set to 6, the maximum value will be 4. This function is only active if "Select Drive [3913]" = All.

3916		Drives on Ch
Default:		0
Range:		0 to (the number of drives - 2)

## Upper Band [3917]

If the speed of the master drive comes into the upper band, an additional drive will be added after a delay time that is set in "Start delay [3919]".

3917		Upper Band
Default:		10%
Range:		0-100% of total min speed to max speed

### Example

Max Speed = 1500 rpm

Min Speed = 300 rpm

Upper Band = 10%

Start delay will be activated:

Range = Max Speed to Min Speed = 1500-300 = 1200 rpm

10% of 1200 rpm = 120 rpm

Start level = 1500-120 = 1380 rpm

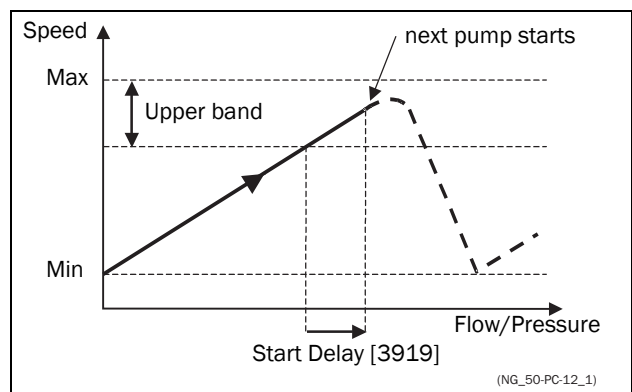

Fig. 127 Upper band.

## Lower Band [3918]

If the speed of the master drive comes into the lower band an additional drive will be stopped after a delay time. This delay time is set in the parameter “Stop Delay [391A]”.

3918 Lower Band	
Default:	10%
Range:	0-100% of total min speed to max speed

### Example

Max Speed = 1500 rpm

Min Speed = 300 rpm

Lower Band = 10%

Stop delay will be activated:

Range = Max Speed - Min Speed = 1500-300 = 1200 rpm

10% of 1200 rpm = 120 rpm

Start level = 300 + 120 = 420 rpm

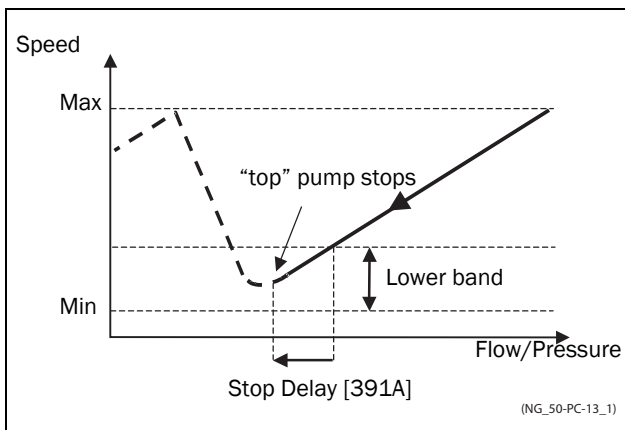

Fig. 128 Lower band.

## Start Delay [3919]

This delay time must have elapsed before the next pump is started. A delay time prevents the nervous switching of pumps.

3919 Start Delay	
Default:	0 s
Range:	0-999 s

## Stop Delay [391A]

This delay time must have elapsed before the 'top' pump is stopped. A delay time prevents the nervous switching of pumps.

391A Stop Delay	
Default:	0 s
Range:	0-999 s

## Upper Band Limit [391B]

If the speed of the pump reaches the upper band limit, the next pump is started immediately without delay. If a start delay is used this delay will be ignored. Range is between 0%, equalling max speed, and the set percentage for the “UpperBand [3917]”.

391B Upp Band Lim	
Default:	0%
Range:	0 to Upper Band level. 0% (=max speed) means that the Limit function is switched off.

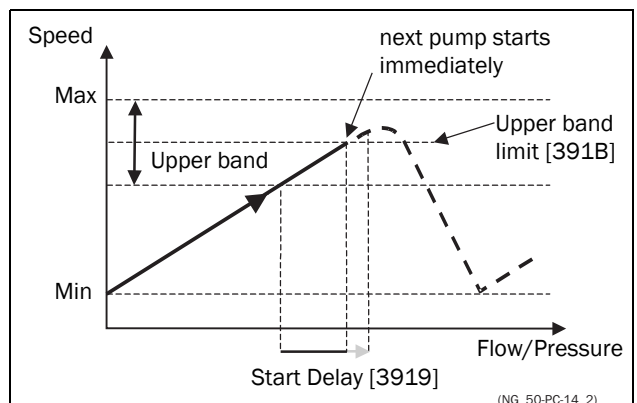

Fig. 129 Upper band limit.

## Lower Band Limit [391C]

If the speed of the pump reaches the lower band limit, the 'top' pump is stopped immediately without delay. If a stop delay is used this delay will be ignored. Range is from 0%, equalling min speed, to the set percentage for the “Lower Band [3918]”.

391C Low Band Lim	
Default:	0%
Range:	0 to Lower Band level. 0% (=min speed) means that the Limit function is switched off.

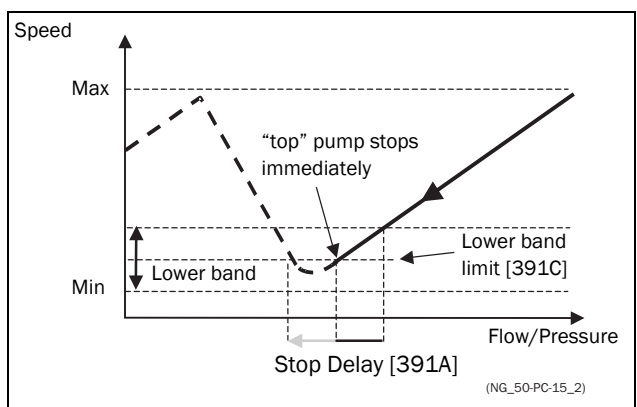

Fig. 130 Lower band limit

### Settle Time Start [391D]

The settle start allows the process to settle after a pump is switched on before the pump control continues. If an additional pump is started D.O.L. (Direct On Line) or Y/Δ, the flow or pressure can still fluctuate due to the 'rough' start/stop method. This could cause unnecessary starting and stopping of additional pumps.

#### During the Settle start:

- PID controller is off.
- The speed will ramp down after adding a pump.

391D Settle Start	
Default:	0 s
Range:	0-999 s

### Transition Speed Start [391E]

The transition speed start is used to minimize a flow/pressure overshoot when adding another pump. When an additional pump needs to be switched on, the master pump will slow down to the set transition speed start value, before the additional pump is started. The setting depends on the dynamics of both the master drive and the additional drives.

The transition speed is best set by trial and error.

#### In general:

- If the additional pump has 'slow' start/stop dynamics, then a higher transition speed should be used.
- If the additional pump has 'fast' start/stop dynamics, then a lower transition speed should be used.

391E TransS Start	
Default:	60%
Range:	0-100% of total min speed to max speed

**NOTE:** If set to 100 %, the transition speed, when starting pumps, is ignored and no speed adaption is made.

I.e. the slave pump is started directly and speed of the master pump is maintained.

### Example

Max Speed = 1500 rpm

Min Speed = 200 rpm

TransS Start = 60%

When an additional pump is needed, the speed will be controlled down to min speed + (60% x (1500 rpm - 200 rpm)) = 200 rpm + 780 rpm = 980 rpm. When this speed is reached, the additional pump with the lowest run time hours will be switched on.

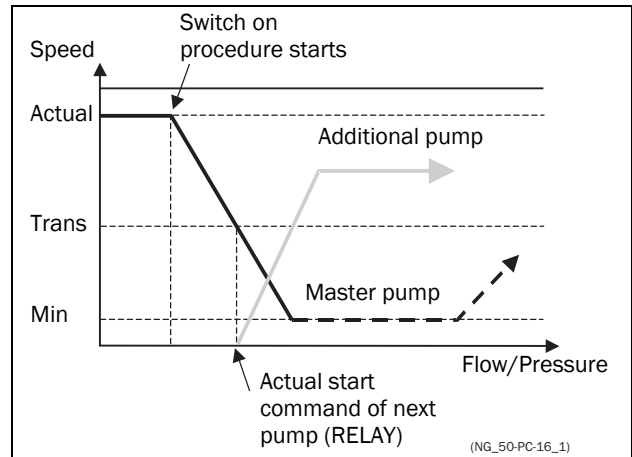

Fig. 131 Transition speed start

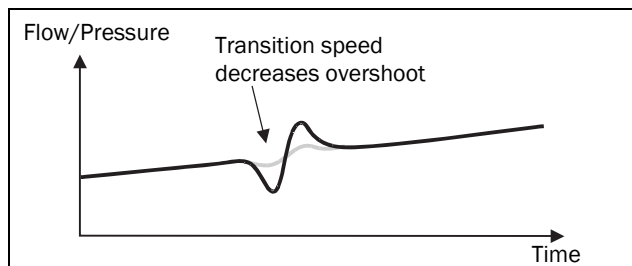

Fig. 132 Effect of transition speed

### Settle Time Stop [391F]

The settle stop allows the process to settle after a pump is switched off before the pump control continues. If an additional pump is stopped D.O.L. (Direct On Line) or Y/Δ, the flow or pressure can still fluctuate due to the 'rough' start/stop method. This could cause unnecessary starting and stopping of additional pumps.

#### During the Settle stop:

- PID controller is off.
- the speed will ramp down after adding a pump.

391F Settle Stop	
Default:	0 s
Range:	0-999 s

## Transition Speed Stop [391G]

The transition speed stop is used to minimize a flow/pressure overshoot when shutting down an additional pump. The setting depends on the dynamics of both the master drive and the additional drives.

### In general:

- If the additional pump has 'slow' start/stop dynamics, then a higher transition speed should be used.
- If the additional pump has 'fast' start/stop dynamics, then a lower transition speed should be used.

391G TransS Stop	
Default:	60%
Range:	0-100% of total min speed to max speed

**NOTE:** If set to 0 %, the transition speed when stopping pumps, is ignored and no speed adaption is made.

I.e. the slave pump is stopped directly and speed of the master pump is continued.

### Example

Max Speed = 1500 rpm

Min Speed = 200 rpm

TransS Start = 60%

When less additional pumps are needed, the speed will be controlled up to min speed +  $(60\% \times (1500 \text{ rpm} - 200 \text{ rpm})) = 200 \text{ rpm} + 780 \text{ rpm} = 980 \text{ rpm}$ . When this speed is reached, the additional pump with the highest run time hours will be switched off.

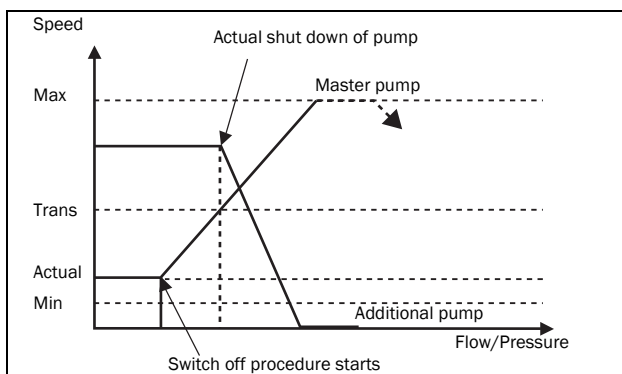

Fig. 133 Transition speed stop

## Run Times 1-6 [391H] to [391M]

391H Run Time 1	
Unit:	h:mm:ss (hours:minutes:seconds)
Range:	0:00:00–262143:59:59

## Reset Run Times 1-6 [391H1] to [391M1]

391H1 Rst Run Tm1		
Default:	No	
No	0	
Yes	1	

## Pump Status [391N]

391N Pump 123456	
Indication	Description
C	Control, master pump, only when alternating master is used
D	Direct control
O	Pump is off
E	Pump error

## Number backup/reserve [391P]

Sets the number of pumps used for backup/reserve which in normal conditions can not be selected. This function can be used for increasing redundancy in the pump system by having pumps in reserve that can be activated when some pumps indicate fault or are shut off for maintenance.

391P No of Backup	
Default:	0
Range:	0-3

## Master change [391Q]

Change master pump without ramping down the frequency.

391Q MastChNoRamp	
Default:	Off
0	Off
1	On

## Pump Cleaning [392]

Pumps can be clogged. Such problems either emerge from gradual buildup of small fibers on the impeller or bigger objects being stuck in the pump. Often these objects can be cleaned from the pump by interrupting normal control to run the pump for a short period of time in high reverse speed and then for a short while in high forward speed.

**NOTE:** Pump cleaning is blocked if menu Pump Enable [3911] is set to "On".

### Pump Cleaning enable [3921]

**NOTE:** Make sure that reverse pump operation is supported before activating the function.

This menu enables pump cleaning.

3921 PC Enable		
Default:		Off
Off	0	Disables pump cleaning and pump cleaning is aborted if set to "Off" during pump cleaning.
On-Warn	1	Enables pump cleaning. Triggers a warning upon reaching max pump cleaning attempts.
On-Trip	2	Enables pump cleaning. Trips upon reaching max pump cleaning attempts.

### Pump Cleaning allow [3922]

Allows pump cleaning if triggered.

3922 PC Allow		
Default:		On
Off	0	Pump cleaning is not allowed.
On	1	Allows pump cleaning.
Once	2	"Once" is reset to "Off" when a pump cleaning has started.

**NOTE:** Pump cleaning is blocked if menu PC Allow [3922] is set to "Off".

## Pump Cleaning Trigger [392A]

### 392A PC Trigger

### Force [392A1]

Force pump cleaning can be selected from this menu. The force signal is reset to "Off" when the pump cleaning starts.

### 392A1 Force

Default:		Off
Off	0	
On	1	

### Each Start [392A2]

Request pump cleaning at each start.

### 392A2 EachStart

Default:		Off
Off	0	
On	1	

### Load Monitor Marg [392A3]

Request pump cleaning each time the load exceeds normal load (as set in menu 41B) + LoadMonMarg.

### 392A3 LoadMonMarg

Default:		Off
Range:		Off, 1 % - 400 % (Off=0)

### Load monitor Trig delay [392A4]

Time above load monitor threshold before requesting pump cleaning.

### 392A4 LMTrigDelay

Default:		0.1 s
Range:		0-90 s

### Runtime [392A5]

Periodic pump cleaning based on runtime. The period timer is reset when cleaning starts independent of trigger or if motor is stopped.

### 392A5 RunTime

Default:		Off
Range:		Off, 1-876 h (Off=0)

### Interval [392A6]

Weeks between repeated weekly schedule.

<b>392A6 Interval</b>	
Default:	Off
Range:	Off, 1-63 weeks (Off=0)

### Weekday [392A7]

Weekdays to schedule pump cleaning.

The deactivated weekdays are replaced by a dash mark “-” (e.g. “MTWTF--”).

<b>392A7 Weekday</b>	
Default:	----- (none activated)
Range:	Monday, Tuesday, Wednesday, Thursday, Friday, Saturday, Sunday.

### Start time [392A8]

Time to run scheduled pump cleaning.

<b>392A8 StartTime</b>	
Default:	00:00:00 (hh:mm:ss)
Range:	0:00:00–23:59:59

### Start date [392A9]

Date for next scheduled pump cleaning.

<b>392A9 StartDate</b>	
Default:	2000-00-00 (year-month-day)

### Pump Cleaning Phase 1 [392B]

<b>392B PC Phase1</b>	
-----------------------	--

### Phase 1 Time [392B1]

This phase is skipped if set to “Off”.

<b>392B1 Ph1 Time</b>	
Default:	10 s
Range:	Off, 1-600 s (Off=0)

### Phase 1 Reference speed [392B2]

Reference speed, in percent of max speed, used during Phase 1.

<b>392B2 Ph1 RefSpd</b>	
Default:	-100 %
Range:	-100 % - 100 %

### Phase 1 Acceleration time [392B3]

Acceleration time (time it would take from 0 to nominal rpm) used for phase 1

<b>392B3 Ph1 AccTime</b>	
Default:	Off (standard)
Range:	0.1 s - 3600 s (Off=0)

### Phase 1 Deceleration time [392B4]

Deceleration time (time it would take from nominal to 0 rpm) used for phase 1.

<b>392B4 Ph1 DecTime</b>	
Default:	Off (standard)
Range:	0.1 s - 3600 s (Off=0)

### Pump Cleaning Phase 2 [392C]

See menus for Pump cleaning Phase 1 [392B].

See Chapter 15 Menu List for defaults.

Selections in the menus [392C] are valid for phase 2.

### Pump Cleaning Phase 3 [392D]

See menus for Pump cleaning Phase 1 [392B].

See Chapter 15 Menu List for defaults.

Selections in the menus [392D] are valid for phase 3.

### Number of pump cleaning attempts [392E]

Number of cleaning attempts before warning/trip. The drive should give a “MaxPumpClean” warning or trip, depending on PC Enable [3921], when initiating pump cleaning if AttemptCnt [392F2] is equal to this value.

<b>392E PC MaxAttmpt</b>	
Default:	8
Range:	Off, 1-15 (Off=0, no limit)

### Pump cleaning status [392F]

Shows the current pump cleaning state.

<b>392F PC Status</b>	
-----------------------	--

## State [392F1]

392F1 State		
Default:		Off
Off	0	Pump cleaning is not running.
Requested	1	Pump cleaning is requested but not allowed to run.
Active	2	Pump cleaning is running.

## Pump cleaning attempts [392F2]

Counter of pump cleaning attempts. The counter is incremented at the start of each cleaning event. The counter is decremented (if greater than zero) each 15 minutes without a cleaning event. Counter is resettable from menu ResetCnt [392F3].

392F2 AttemptCnt	
Range:	0-15

## Reset of pump cleaning attempts [392F3]

Resets AtmptCnt [392F2] to 0 upon selecting "Yes".

392F3 ResetCnt	
No	0
Yes	1

## Total pump cleaning attempts [392F4]

Counter of total pump cleaning attempts. The counter is incremented at the start of each cleaning event. Does not decrement. User resettable from menu TotCntReset [392F6].

392F4 TotCnt	
Range:	0 - 65535

## Total hours since last reset [392F5]

Hours since TotCnt [392F4] was last reset.

392F5 TotCntSince	
Range:	0 - 65535 h

## Total counter reset [392F6]

Resets TotCnt [392F4] to 0 upon selecting "Yes".

392F6 TotCntReset	
No	0
Yes	1

## 11.3.11 Crane Option [3A0]

Settings for the optional Crane board (Crane Remote Input/Output card) and external IO-Interface. See also the Crane option instruction manual or IO-Interface instruction manual.

---

**NOTE: This menu is only visible if the crane board or the external IO-Interface is connected to the AC drive.**

---

## Crane enable [3A1]

When the crane option board is connected, it is possible to (de)activate the crane option board inputs.

---

**NOTE: Deviation function is also active even if [3A1]=off.**

---

3A1 Crane enable		
Default:		Off
Off	0	Crane option board deactivated
On	1	Crane option board activated
Serial Com	2	External IO-Interface activated

## Control [3A2]

To select the type of crane joystick control.

3A2 Control		
Default:		4-Speeds
4-Speeds	0	4-Speed joystick
3-Pos	1	3-Position switch
Analogue	2	Analogue joystick

## Crane Relay CR1 [3A3]

Crane Relay CR1 on the Crane option board is fixed to the No Trip function.

3A3 Crane Relay1	
Default:	No Trip
Selections	Fixed to No Trip

## Crane Relay CR2 [3A4]

To select the function of Crane Relay CR2 on the Crane option board. Same selections as for the relays on the control board.

3A4 Crane Relay2	
Default:	Brake
Selections	Same selections as for the relays on the control board

## Pre Limit Switch Speed [3A5]

To set the speed used when Pre-Limit Switch on the Crane option board is active.

3A5 PreLimSwSpd	
Default:	0 rpm
Range:	0 – 4 x Motor Sync speed

NOTE: Speed signal is limited to < 32767.

## Crawl speed H/R [3A6]

To set the speed used when crawling (min. speed) during a hoisting operation. Activated with input A1, Crawl H/R=Start in positive speed direction.

3A6 CrawlSpd H/R	
Default:	0
Range:	0 – 4 x Sync speed

NOTE: Speed signal is limited to < 32767.

## Crawl speed L/L [3A7]

To set the speed used when crawling (min. speed) during lowering operation. Activated with input A2, Crawl L/L=Start in negative speed direction.

3A7 CrawlSpd L/L	
Default:	0
Range:	0 – 4 x Sync speed

NOTE: Speed signal is limited to < 32767.

## Speed 2 [3A8]

To set the speed used when the input B1, Speed 2 on the Crane option board is active.

3A8 Speed 2	
Default:	0
Range:	0 – 4 x Sync speed

NOTE: Speed signal is limited to < 32767.

## Speed 3 [3A9]

To set the speed used when the input B2, Speed 3 on the Crane option board is active.

3A9 Speed 3	
Default:	0
Range:	0 – 4 x Motor Sync speed

NOTE: Speed signal is limited to < 32767.

## Speed 4 [3AA]

To set the speed used when the input B3, Speed 4 on the Crane option board is active.

3AA Speed 4	
Default:	0
Range:	0 – 4 x Motor Sync speed

NOTE: Speed signal is limited to < 32767.

## Deviation Band width [3AB]

To define the speed deviation window within which the AC drive is in control of the motor.

3AB Dev Bandwidt	
Default:	0
Range:	0 – 4 x Sync speed

NOTE: Speed signal is limited to < 32767.

## Deviation Time [3AC]

To set the time during which the deviation condition must be active, before the inverter trips.

3AC Dev Time	
Default:	0.10 s
Range:	0.05 – 1 s

## LAFS Load [3AD]

To set the load below which the VFX goes into load dependent field weakening operation.

3AD LAFS Load		
Default:	Off	
Off	0	Off
1-100	1-100	1% – 100%

When set to OFF, the load dependent field weakening function is switched off.

---

**NOTE: Not used with external IO-Interface.**

---

## CRIO N input function [3AG]

Sets the function of CRIO/Crane I/O interface N(Null) input.

3AG Crane N Func		
Default:		Zero Pos
Off	0	N input not used
Zero pos	1	N input used for joystick zero position indication.
Brk Ackn	2	N input used for Brake Acknowledge. See page 140.

---

**Note: Brake Acknowledge via Crane I/O has priority (and overrules) Brake acknowledge via control board I/O ([521 DigIn1] - [528 Dig In8]).**

---



## 11.4 Load Monitor and Process Protection [400]

### 11.4.1 Load Monitor [410]

The monitor functions enable the AC drive to be used as a load monitor. Load monitors are used to protect machines and processes against mechanical overload and underload, e.g. a conveyer belt or screw conveyer jamming, belt failure on a fan and a pump dry running. See explanation in Section 7.5 "Load Monitor and Process Protection [400]".

### Alarm Select [411]

Selects the types of alarms that are active.

411 Alarm Select		
Default:		Off
Off	0	No alarm functions active.
Min	1	Min Alarm active. The alarm output functions as an underload alarm.
Max	2	Max Alarm active. The alarm output functions as an overload alarm.
Min+Max	3	Both Min and Max alarm are active. The alarm outputs function as overload and underload alarms.

### Alarm Trip [412]

Selects which alarm must cause a trip to the AC drive.

412 Alarm trip	
Default:	Off
Selection:	Same as in menu [411]

### Ramp Alarm [413]

This function inhibits the (pre) alarm signals during acceleration/deceleration of the motor to avoid false alarms.

413 Ramp Alarm		
Default:		Off
Off	0	(Pre) alarms are inhibited during acceleration/deceleration.
On	1	(Pre) alarms active during acceleration/deceleration.

### Alarm Start Delay [414]

This parameter is used if, for example, you want to override an alarm during the start-up procedure.

Sets the delay time after a run command, after which the alarm may be given.

- If Ramp Alarm=On. The start delay begins after a RUN command.
- If Ramp Alarm=Off. The start delay begins after the acceleration ramp.

414 Start Delay	
Default:	2 s
Range:	0-3600 s

### Load Type [415]

In this menu you select monitor type according to the load characteristic of your application. By selecting the required monitor type, the overload and underload alarm function can be optimized according to the load characteristic.

When the application has a constant load over the whole speed range, i.e. extruder or screw compressor, the load type can be set to basic. This type uses a single value as a reference for the nominal load. This value is used for the complete speed range of the AC drive. The value can be set or automatically measured. See Autoselect Alarm [41A] and "Normal Load [41B]" about setting the nominal load reference.

The Load Curve mode uses an interpolated curve with 9 load values at 8 equal speed intervals. This curve is populated by a test run with a real load. This can be used with any smooth load curve including constant load.

The Load Curve R is a relative load curve in % of Load set in the Load Curve. There is also a minimum margin set in menu "Minimum Absolute Margin [41D]".

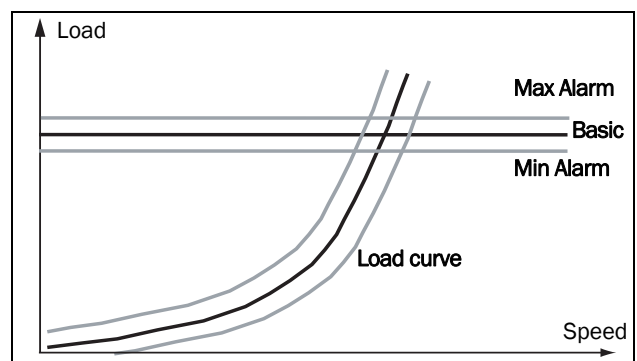

Fig. 134 Basic load type and Load curve.

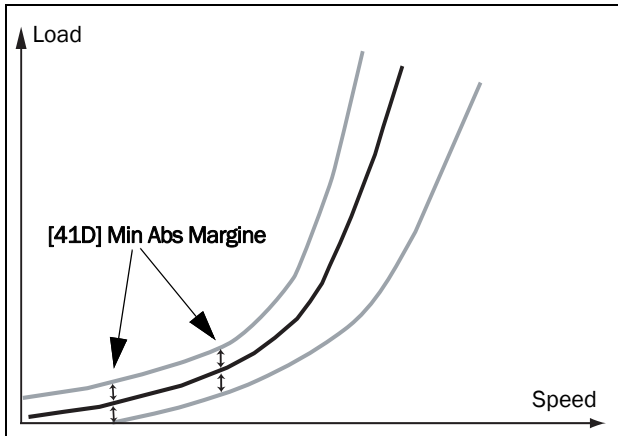

Fig. 135 Load Curve R with Min ABS margin.

415		Load Type
Default:		Load Constant
Load Constant	0	Uses a fixed maximum and minimum load level over the full speed range. Can be used in situations where the torque is independent of the speed.
Load Curve	1	Uses the measured actual load characteristic of the process over the speed range.
Load Curve R	2	Uses a relative load margin with a minimum margin set in menu [41D].

## Max Alarm [416]

### Max Alarm Margin [4161]

With load type Basic, [415], used the Max Alarm Margin sets the band above the “Normal Load [41B]” menu that does not generate an alarm. With load type Load Curve [415] used, the Max Alarm Margin sets the band above the Load Curve [41C], that does not generate an alarm. The Max Alarm Margin is a percentage of nominal motor torque.

In case of Load Curve R, the margin is percentage of Load curve torque at the actual speed.

4161		MaxAlarmMar
Default:		15%
Range:		0–400%

### Max Alarm delay [4162]

When the load level without interruption exceeds the alarm level longer than set “Max Alarm delay” time, an alarm is activated.

4162		MaxAlarmDel
Default:		0.1 s
Range:		0–90 s

## Max Pre Alarm [417]

### Max Pre AlarmMargin [4171]

With load type Basic [415], used the Max Pre-Alarm Margin sets the band above the Normal Load, [41B], menu that does not generate a pre-alarm. With load type Load Curve, [415], used the Max Pre-Alarm Margin sets the band above the Load Curve, [41C], that does not generate a pre-alarm. The Max Pre-Alarm Margin is a percentage of nominal motor torque.

In case of Load Curve R, the margin is percentage of Load curve torque at the actual speed.

4171		MaxPreAlMar
Default:		10%
Range:		0–400%

### Max Pre Alarm delay [4172]

When the load level without interruption exceeds the alarm level longer than set “Max PreAlarm delay” time, a warning is activated.

4172		MaxPreAlDel
Default:		0.1 s
Range:		0–90 s

## Min Pre Alarm [418]

### Min Pre Alarm Margin [4181]

With load type Basic, [415], used the Min Pre-Alarm Margin sets the band under the Normal Load, [41B], menu that does not generate a pre-alarm. With load type Load Curve, [415], used the Min Pre-Alarm Margin sets the band under the Load Curve, [41C], that does not generate a pre-alarm. The Min Pre-Alarm Margin is a percentage of nominal motor torque.

In case of Load Curve R, the margin is percentage of Load curve torque at the actual speed.

4181 MinPreAlMar	
Default:	10%
Range:	0-400%

### Min Pre Alarm Response delay [4182]

When the load level without interruption is below the alarm level longer than set “Min PreAlarm delay” time, a warning is activated.

4182 MinPreAlDel	
Default:	0.1 s
Range:	0-90 s

## Min Alarm [419]

### Min Alarm Margin [4191]

With load type Basic, [415], used the Min Alarm Margin sets the band under the “Normal Load [41B]”, menu that does not generate an alarm. With load type “Load Curve [415]”, used the Min Alarm Margin sets the band under the “Load Curve [41C]”, that does not generate an alarm. The Max Alarm Margin is a percentage of nominal motor torque.

In case of Load Curve R, the margin is percentage of Load curve torque at the actual speed.

4191 MinAlarmMar	
Default:	15%
Range:	0-400%

## Min Alarm Response delay [4192]

When the load level without interruption is below the alarm level longer than set “Min Alarm delay” time, an alarm is activated.

4192 MinAlarmDel	
Default:	0.1 s
Range:	0-90 s

## Autoset Alarm [41A]

The Autoset Alarm function can measure the nominal load that is used as reference for the alarm levels. If the selected “Load Type [415]” is Basic it copies the load the motor is running with to the menu “Normal Load [41B]”. The motor must run on the speed that generates the load that needs to be recorded. If the selected “Load Type [415]” is Load Curve it performs a test-run and populates the “Load Curve [41C]” with the found load values.



### WARNING!

When autoset does a test run the motor and application/machine will ramp up to maximum speed.

**NOTE:** The motor must be running for the Autoset Alarm function to succeed. A not running motor generates a “Failed!” message.

41A AutoSet Alarm		
Default:	No	
No	0	
Yes	1	

The default set levels for the (pre)alarms are:

Overload	Max Alarm	menu [4161] + [41B]
	Max Pre Alarm	menu [4171] + [41B]
Underload	Min Pre Alarm	menu [41B] - [4181]
	Min Alarm	menu [41B] - [4191]

These default set levels can be manually changed in menus [416] to [419]. After execution the message “Autoset OK!” is displayed for 1s and the selection reverts to “No”.

## Normal Load [41B]

Set the level of the normal load. The alarm or pre alarm will be activated when the load is above/under normal load  $\pm$  margin.

41B Normal Load	
Default:	100%
Range:	0-400% of max torque

**NOTE:** 100% Torque means:  $I_{NOM} = I_{MOT}$ . The maximum depends on the motor current and AC drive max current settings, but the absolute maximum adjustment is 400%.

## Load Curve [41C]

The load curve function can be used with any smooth load curve. The curve can be populated with a test-run or the values can be entered or changed manually.

### Load Curve 1-9 [41C1] - [41C9]

The measured load curve is based on 9 stored samples. The curve starts at minimum speed and ends at maximum speed, the range in between is divided into 8 equal steps. The measured values of each sample are displayed in [41C1] to [41C9] and can be adapted manually. The value of the 1st sampled value on the load curve is displayed.

41C1 Load Curve1	
Default:	100%
Range:	0-400% of max torque

**NOTE:** Speed signals are limited to < 32767.

**NOTE:** The speed values depend on the Min- and Max Speed values. they are read only and cannot be changed.

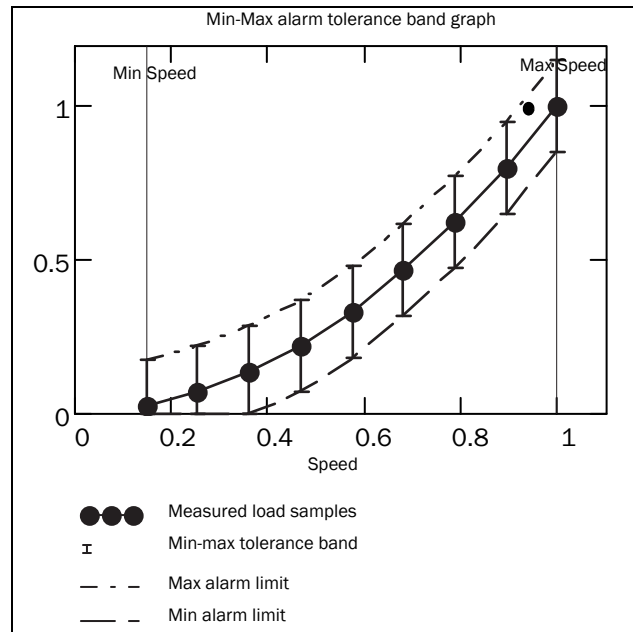

Fig. 136

## Minimum Absolute Margin [41D]

This menu is displayed when using "Load Curve R" Set absolute minimum margin of the Load Curve in % of nominal motor torque.

41D MinAbsMarg	
Default:	3 %
Range:	0 - 31 %

## 11.4.2 Process Protection [420]

Submenu with settings regarding protection functions for the AC drive and the motor.

### Low Voltage Override [421]

The motor is as default stopped when there is a dip in the mains supply. LVO control and LVO sleep try to override a stop at low voltage.

### Low Voltage Override Control [4211]

If a dip in the mains supply occurs and the low voltage override control function is enabled, the AC drive will automatically decrease the motor speed to keep control of the application and prevent an under voltage trip until the input voltage rises again. Therefore the rotating energy in the motor/load is used to keep the DC link voltage level at the override level, for as long as possible or until the motor comes to a standstill. This is dependent on the inertia of the motor/load combination and the load of the motor at the time the dip occurs, see Fig. 137.

4211 LVO Control		
Default:	On	
Off	0	At a voltage dip the low voltage trip will protect.
On	1	At mains dip, AC drive ramps down until voltage rises.

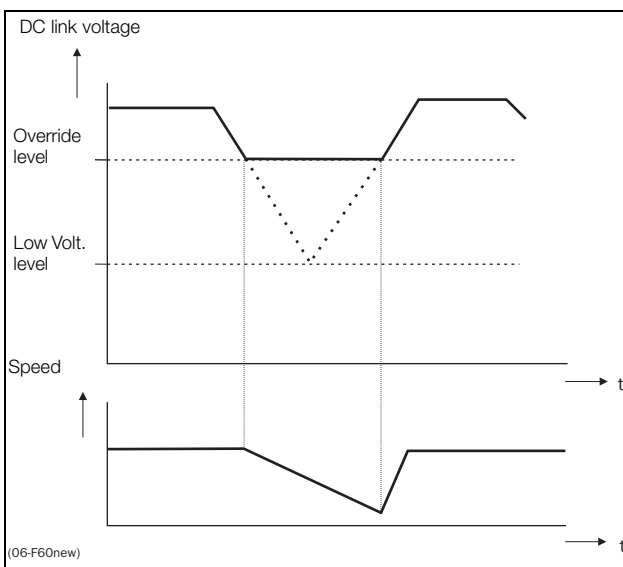

Fig. 137 Low voltage override control

**NOTE:** During the low voltage override the LED trip/limit blinks.

**NOTE:** LVO and OVC are not active in torque mode.

### Low Voltage Override Sleep Time [4212]

LVO sleep mode disables the low voltage trip and preserves the run command. This means that the motor will restart automatically, after a power dip, if the voltage returns within the set time. Detection of low voltage, provided that LVO control has become inactive (standstill or not enabled), enables the LVO sleep mode.

4212 LVO Sleep Time		
Default:	Off	
Range:	Off, 1-30s (Off=0)	

**NOTE:** The motor will coast as soon as the inverter enters LVO sleep mode. We therefore recommend activating spin start [33A] if LVO control [4211] is disabled.

### Rotor locked [422]

With the rotor locked function enabled, the AC drive will protect the motor and application when this is stalled whilst increasing the motor speed from standstill. This protection will coast the motor to stop and indicate a fault when the Torque Limit has been active at very low speed for more than 5 seconds.

422 Rotor Locked		
Default:	Off	
Off	0	No detection
On	1	AC drive will trip when locked rotor is detected. Trip message "Locked Rotor".

### Motor lost [423]

With the motor lost function enabled, the AC drive is able to detect a fault in the motor circuit: motor, motor cable, thermal relay or output filter. Motor lost will cause a trip, and the motor will coast to standstill, when a missing motor phase is detected during a period of 500 ms. The detection time during DC-start is 50 ms and during Fast-start 10 ms.

423 Motor lost		
Default:	Off	
Off	0	Function switched off to be used if no motor or very small motor connected.
Trip	1	AC drive will trip when the motor is disconnected. Trip message "Motor Lost".
Start	2	Test for disconnected motor will only be performed during start routine.

## Overvolt control [424]

Used to switch off the overvoltage control function when only braking by brake chopper and resistor is required. The overvoltage control function, limits the braking torque so that the DC link voltage level is controlled at a high, but safe, level. This is achieved by limiting the actual deceleration rate during stopping. In case of a defect at the brake chopper or the brake resistor the AC drive will trip for “Overvoltage” to avoid a fall of the load e.g. in crane applications.

---

**NOTE: Overvoltage control should not be activated if brake chopper is used.**

---

424 OverVolt Ctl		
Default:		On
Off	0	Overvoltage control off
On	1	Overvoltage control activated

---

**NOTE: LVO and OVC are not active in torque mode.**

---

## 11.4.3 Trip text [430]

### ExtTrip1 Text [431]

Used for custom external trip messages of maximum 16 characters. Editing of the message text is done according to the same principles as described for the Unit name [923].

431 ExtTrip1Text	
Default:	Ext Trip 1

### ExtTrip2 Text [432]

Used for custom external trip messages of maximum 16 characters. Editing of the message text is done according to the same principles as described for the Unit name [923].

432 ExtTrip2Text	
Default:	Ext Trip 2

### ExtTrip3 Text [433]

Used for custom external trip messages of maximum 16 characters. Editing of the message text is done according to the same principles as described for the Unit name [923].

433 ExtTrip3Text	
Default:	Ext Trip 3

### ExtTrip4 Text [434]

Used for custom external trip messages of maximum 16 characters. Editing of the message text is done according to the same principles as described for the Unit name [923].

434 ExtTrip4Text	
Default:	Ext Trip 4

## 11.5 I/Os and Virtual Connections [500]

Main menu with all the settings of the standard inputs and outputs of the AC drive.

### 11.5.1 Analogue Inputs [510]

Submenu with all settings for the analogue inputs.

#### AnIn1 Function [511]

Sets the function for Analogue input 1. Scale and range are defined by AnIn1 Advanced settings [513].

511 AnIn1 Fc		
Default:		Process Ref
Off	0	Input is not active
Max Speed	1	The input acts as an upper speed limit.
Max Torque	2	The input acts as an upper torque limit.
Process Val	3	The input value equals the actual process value (feedback) and is compared to the reference signal (set point) by the PID controller, or can be used to display and view the actual process value.
Process Ref	4	Reference value is set for control in process units, see Process Source [321] and Process Unit [322].
Min Speed	5	The input acts as a lower speed limit.

**NOTE: When AnInX Func=Off, the connected signal will still be available for Comparators [610].**

#### Adding analogue inputs

If more than one analogue input is set to the same function, the values of the inputs can be added together. In the following examples we assume that Process Source [321] is set to Speed.

Example 1: Add signals with different weight (fine tuning).

Signal on AnIn1 = 10 mA

Signal on AnIn2 = 5 mA

[511] AnIn1 Function = Process Ref.

[512] AnIn1 Setup = 4-20 mA

[5134] AnIn1 Function Min = Min (0 rpm)

[5136] AnIn1 Function Max = Max (1500 rpm)

[5138] AnIn1 Operation = Add+

[514] AnIn2 Function = Process Ref.

[515] AnIn2 Setup = 4-20 mA

[5164] AnIn2 Function Min = Min (0 rpm)

[5166] AnIn2 Function Max = User defined

[5167] AnIn2 Value Max = 300 rpm

[5168] AnIn2 Operation = Add+

Calculation:

$$\text{AnIn1} = (10-4) / (20-4) \times (1500-0) + 0 = 562.5 \text{ rpm}$$

$$\text{AnIn2} = (5-4) / (20-4) \times (300-0) + 0 = 18.75 \text{ rpm}$$

The actual process reference will be:

$$+562.5 + 18.75 = 581 \text{ rpm}$$

#### Analogue Input Selection via Digital Inputs

When two different external Reference signals are used, e.g. 4-20mA signal from control centre and a 0-10 V locally mounted potentiometer, it is possible to switch between these two different analogue input signals via a Digital Input set to "AnIn Select".

AnIn1 is 4-20 mA

AnIn2 is 0-10 V

DigIn3 is controlling the AnIn selection; HIGH is 4-20 mA, LOW is 0-10 V

"[511] AnIn1 Fc" = Process Ref;  
set AnIn1 as reference signal input

"[512] AnIn1 Setup" = 4-20mA;  
set AnIn1 for a current reference signal

"[513A] AnIn1 Enabl" = DigIn;  
set AnIn1 to be active when DigIn3 is HIGH

"[514] AnIn2 Fc" = Process Ref;  
set AnIn2 as reference signal input

"[515] AnIn2 Setup" = 0-10V;  
set AnIn2 for a voltage reference signal

"[516A] AnIn2 Enabl" = !DigIn;  
set AnIn2 to be active when DigIn3 is LOW

"[523] DigIn3=AnIn";  
set DigIn3 as input for selection of AI reference

#### Subtracting analogue inputs

Example 2: Subtract two signals

Signal on AnIn1 = 8 V

Signal on AnIn2 = 4 V

[511] AnIn1 Function = Process Ref.

[512] AnIn1 Setup = 0-10 V

[5134] AnIn1 Function Min = Min (0 rpm)

[5136] AnIn1 Function Max = Max (1500 rpm)

[5138] AnIn1 Operation = Add+

[514] AnIn2 Function = Process Ref.

[515] AnIn2 Setup = 0-10 V

[5164] AnIn2 Function Min = Min (0 rpm)

[5166] AnIn2 Function Max = Max (1500 rpm)

[5168] AnIn2 Operation = Sub-

Calculation:

$$\text{AnIn1} = (8-0) / (10-0) \times (1500-0) + 0 = 1200 \text{ rpm}$$

$$\text{AnIn2} = (4-0) / (10-0) \times (1500-0) + 0 = 600 \text{ rpm}$$

The actual process reference will be:

$$+1200 - 600 = 600 \text{ rpm}$$

## AnIn1 Setup [512]

The analogue input setup is used to configure the analogue input in accordance with the signal used that will be connected to the analogue input. With this selection the input can be determined as current (4-20 mA) or voltage (0-10 V) controlled input. Other selections are available for using a threshold (live zero), a bipolar input function, or a user defined input range. With a bipolar input reference signal, it is possible to control the motor in two directions. See Fig. 138.

**NOTE:** The selection of voltage or current input is done with S1. When the switch is in voltage mode only the voltage menu items are selectable. With the switch in current mode only the current menu items are selectable.

512 AnIn1 Setup		
Default:	4-20 mA	
Dependent on	Setting of switch S1	
4-20mA	0	The current input has a fixed threshold (Live Zero) of 4 mA and controls the full range for the input signal. See Fig. 140.
0-20mA	1	Normal full current scale configuration of the input that controls the full range for the input signal. See Fig. 139.
User mA	2	The scale of the current controlled input, that controls the full range for the input signal. Can be defined by the advanced AnIn Min and AnIn Max menus.
User Bipol mA	3	Sets the input for a bipolar current input, where the scale controls the range for the input signal. Scale can be defined in advanced menu AnIn Bipol.
0-10V	4	Normal full voltage scale configuration of the input that controls the full range for the input signal. See Fig. 139.
2-10V	5	The voltage input has a fixed threshold (Live Zero) of 2 V and controls the full range for the input signal. See Fig. 140.
User V	6	The scale of the voltage controlled input, that controls the full range for the input signal. Can be defined by the advanced AnIn Min and AnIn Max menus.
User Bipol V	7	Sets the input for a bipolar voltage input, where the scale controls the range for the the input signal. Scale can be defined in advanced menu AnIn Bipol.

**NOTE:** For bipolar function, input RunR and RunL needs to be active and Rotation, [219] must be set to "R+L".

**NOTE:** Always check the needed set up when the setting of S1 is changed; selection will not adapt automatically.

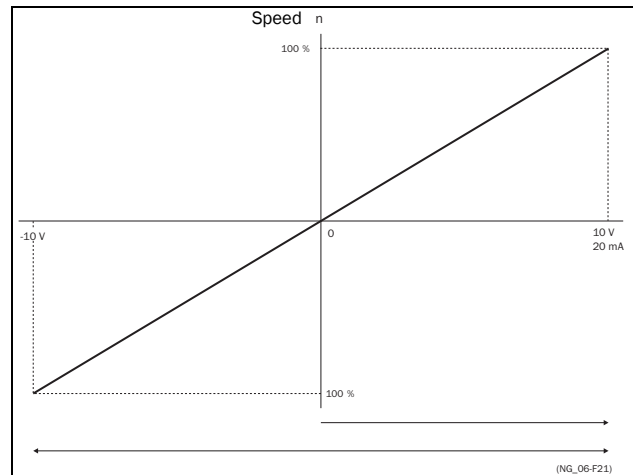

Fig. 138

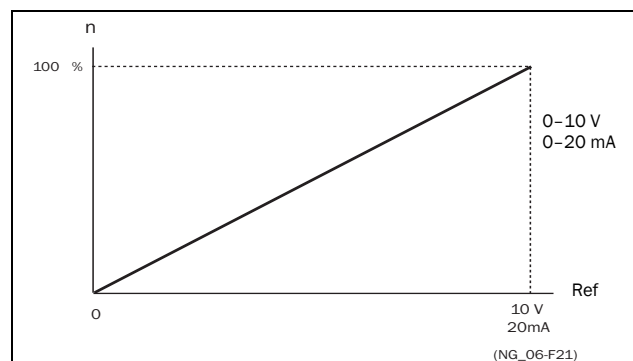

Fig. 139 Normal full-scale configuration

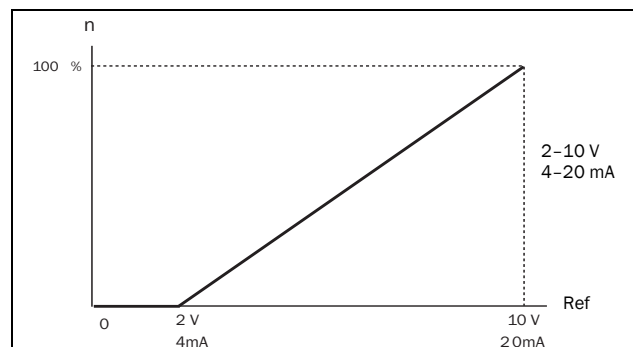

Fig. 140 2-10 V/4-20 mA (Live Zero)

## AnIn1 Advanced [513]

**NOTE:** The different menus will automatically be set to either “mA” or “V”, based on the selection in AnIn 1 Setup [512].

<b>513</b>	<b>AnIn1 Advan</b>
------------	--------------------

### AnIn1 Min [5131]

Parameter to set the minimum value of the external reference signal. Only visible if [512] = User mA/V.

<b>5131</b>	<b>AnIn1 Min</b>
Default:	0 V/4.00 mA
Range:	0.00–20.00 mA 0–10.00 V

### AnIn1 Max [5132]

Parameter to set the maximum value of the external reference signal. Only visible if [512] = User mA/V.

<b>5132</b>	<b>AnIn1 Max</b>
Default:	10.00 V/20.00 mA
Range:	0.00–20.00 mA 0–10.00 V

### Special function: Inverted reference signal

If the AnIn minimum value is higher than the AnIn maximum value, the input will act as an inverted reference input, see Fig. 141.

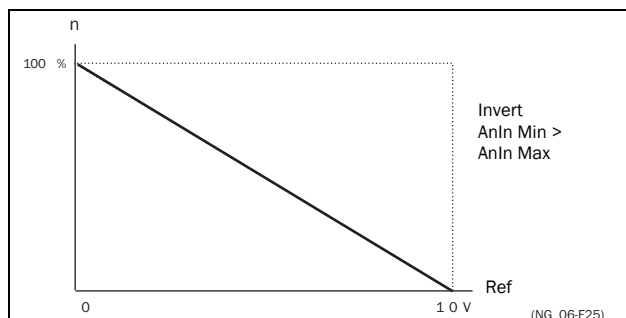

Fig. 141 Inverted reference

## AnIn1 Bipol [5133]

This menu is only displayed if AnIn1 Setup is set to User Bipol mA or User Bipol V. The window will automatically show mA or V range according to selected function. The range is set by changing the positive maximum value; the negative value is automatically adapted accordingly. The inputs RunR and RunL input need to be active, and “Rotation [219]”, must be set to “R+L”, to operate the bipolar function on the analogue input.

<b>5133</b>	<b>AnIn1 Bipol</b>
Default:	10.00 V/20.00 mA
Range:	0.0–20.0 mA, 0.00–10.00 V

### AnIn1 Function Min [5134]

With AnIn1 Function Min the physical minimum value is scaled to selected process unit. The default scaling is dependent of the selected function of AnIn1 [511].

<b>5134</b>	<b>AnIn1 FcMin</b>	
Default:	Min	
Min	0	Min value
Max	1	Max value
User defined	2	Define user value in menu [5135]

Table 36 shows corresponding values for the min and max selections depending on the function of the analogue input [511].

Table 36

AnIn Function	Min	Max
Speed	Min Speed [341]	Max Speed [343]
Torque	0%	Max Torque [351]
Process Ref	Process Min [324]	Process Max [325]
Process Value	Process Min [324]	Process Max [325]

### AnIn1 Function Value Min [5135]

With AnIn1 Function ValMin you define a user-defined value for the signal. Only visible when user-defined is selected in menu [5134].

<b>5135</b>	<b>AnIn1 VaMin</b>
Default:	0.000
Range:	-10000.000 – 10000.000

### AnIn1 Function Max [5136]

With AnIn1 Function Max the physical maximum value is scaled to selected process unit. The default scaling is dependent of the selected function of AnIn1 [511]. See Table 36.

5136 AnIn1 FcMax		
Default:		Max
Min	0	Min value
Max	1	Max value
User defined	2	Define user value in menu [5137]

### AnIn1 Function Value Max [5137]

With AnIn1 Function VaMax you define a user-defined value for the signal. Only visible when user-defined is selected in menu [5136].

5137 AnIn1 VaMax	
Default:	0.000
Range:	-10000.000 – 10000.000

**NOTE:** With AnIn Min, AnIn Max, AnIn Function Min and AnIn Function Max settings, loss of feedback signals (e.g. voltage drop due to long sensor wiring) can be compensated to ensure an accurate process control.

Example:

Process sensor is a sensor with the following specification:

Range: 0–3 bar

Output: 2–10 mA

Analogue input should be set up according to:

[512] AnIn1 Setup = User mA

[5131] AnIn1 Min = 2 mA

[5132] AnIn1 Max = 10 mA

[5134] AnIn1 Function Min = User-defined

[5135] AnIn1 VaMin = 0.000 bar

[5136] AnIn 1 Function Max = User-defined

[5137] AnIn1 VaMax = 3.000 bar

### AnIn1 Operation [5138]

5138 AnIn1 Oper		
Default:		Add+
Add+	0	Analogue signal is added to selected function in menu [511].
Sub-	1	Analogue signal is subtracted from selected function in menu [511].

### AnIn1 Filter [5139]

If the input signal is unstable (e.g. fluctuation reference value), the filter can be used to stabilize the signal. A change of the input signal will reach 63% on AnIn1 within the set AnIn1 Filter time. After 5 times the set time, AnIn1 will have reached 100% of the input change. See Fig. 142.

5139 AnIn1 Filt	
Default:	0.1 s
Range:	0.001 – 10.0 s

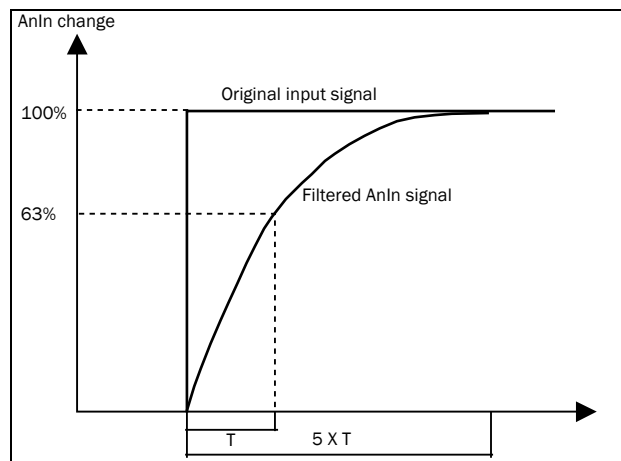

Fig. 142

### AnIn1 Enable [513A]

Parameter for enable/disable analogue input selection via digital inputs (DigIn set to function AnIn Select).

513A AnIn1 Enabl		
Default:		On
On	0	AnIn1 is always active
!DigIn	1	AnIn1 is only active if the digital input is low.
DigIn	2	AnIn1 is only active if the digital input is high.

## AnIn2 Function [514]

Parameter for setting the function of Analogue Input 2.

Same function as “AnIn1 Fc [511]”.

<b>514 AnIn2 Fc</b>	
Default:	Off
Selection:	Same as in menu [511]

## AnIn2 Setup [515]

Parameter for setting the function of Analogue Input 2.

Same functions as “AnIn1 Setup [512]”.

<b>515 AnIn2 Setup</b>	
Default:	4 – 20 mA
Dependent on	Setting of switch S2
Selection:	Same as in menu [512].

## AnIn2 Advanced [516]

Same functions and submenus as under “AnIn1 Advan [513]”.

<b>516 AnIn2 Advan</b>	
------------------------	--

## AnIn3 Function [517]

Parameter for setting the function of Analogue Input 3.

Same function as “AnIn1 Fc [511]”.

<b>517 AnIn3 Fc</b>	
Default:	Off
Selection:	Same as in menu [511]

## AnIn3 Setup [518]

Same functions as “AnIn1 Setup [512]”.

<b>518 AnIn3 Setup</b>	
Default:	4–20 mA
Dependent on	Setting of switch S3
Selection:	Same as in menu [512].

## AnIn3 Advanced [519]

Same functions and submenus as under “AnIn1 Advan [513]”.

<b>519 AnIn3 Advan</b>	
------------------------	--

## AnIn4 Function [51A]

Parameter for setting the function of Analogue Input 4.

Same function as “AnIn1 Fc [511].”

<b>51A AnIn4 Fc</b>	
Default:	Off
Selection:	Same as in menu [511]

## AnIn4 Set-up [51B]

Same functions as “AnIn1 Setup [512]”.

<b>51B AnIn4 Setup</b>	
Default:	4-20 mA
Dependent on	Setting of switch S4
Selection:	Same as in menu [512].

## AnIn4 Advanced [51C]

Same functions and submenus as under “AnIn1 Advan [513]”.

<b>51C AnIn4 Advan</b>	
------------------------	--

## AnIn Fault [51D]

### AnIn Fault Mode [51D1]

Behaviour of drive upon losing analog input signal.

<b>51D1 AnIn FltMode</b>		
Default:		Off
Off	0	No analog input supervision
Trip	1	The AC drive will trip if the analog input signal is below 75% of the configured minimum value.
Warning	2	The AC drive will give a warning if the analog input signal is below 75% of the configured minimum value.
Change Pset	3	Pset is changed according to menu AnInFlt Set [247], It stays in the new Pset until it resets from menu AnIn Reset [51D3] or if this setting is changed to other than "Change Pset".
Const Ref	4	Reference value is set according to menu AnIn FltRef [51D2].
Last Ref	5	The drive attempts to retain the previous analog signal value.

### AnIn FltRef [51D2]

Reference value used upon losing AnIn signal when AnIn FltMode [51D1] is set to "Const Ref".

<b>51D2 AnIn FltRef</b>	
Default:	0 %
Range:	0-100 %

### AnIn Reset [51D3]

When menu [51D1] AnIn FltMode is set to "Change Pset", select "Yes" in this menu (after fixing AnIn signal) to allow the drive to revert to the original Pset.

<b>51D3 AnIn Reset</b>	
No	0
Yes	1

## Analog Input Resolution [51E]

Sets the number of decimals used for analog inputs.

### Analog Input Resolution on the Control Panel [51E1]

Set the number of decimals presented by the control panel.

<b>51E1 CP ANIN Resolution</b>		
Default:		1%
1%	0	No decimals
0.1%	1	One decimal
0.01%	2	Two decimals

### Analog Input Resolution in Communication [51E2]

Set the number of decimals used by the communication interface.

<b>51E2 COM ANIN Resolution</b>		
Default:		1%
1%	0	No decimals
0.1%	1	One decimal
0.01%	2	Two decimals

---

**NOTE:** The EINT format limits the number of significant digits to three.

---

## 11.5.2 Digital Inputs [520]

**NOTE: Additional inputs will become available when the I/O option boards are connected.**

Submenu with all the settings for the digital inputs.

**NOTE: Additional inputs will become available when the I/O option boards are connected.**

### Digital Input 1 [521]

To select the function of the digital input.

On the standard control board there are eight digital inputs.

If the same function is programmed for more than one input that function will be activated according to “OR” logic if nothing else is stated.

521 DigIn 1		
Default:		RunL
Off	0	The input is not active.
Lim Switch +	1	AC drive ramps to stop and prevents rotation in “R” direction (clockwise), when the signal is low! NOTE: The Lim Switch+ is active low. NOTE: Activated according to “AND” logic.
Lim Switch -	2	AC drive ramps to stop and prevents rotation in “L” direction (counter clockwise) when the signal is low! NOTE: The Lim Switch- is active low. NOTE: Activated according to “AND” logic.
Ext. Trip1	3	Be aware that if there is nothing connected to the input, the AC drive will trip at “External trip” immediately. NOTE: The External Trip is active low. NOTE: Activated according to “AND” logic.
Stop	4	Stop command according to the selected Stop mode in menu [33B]. NOTE: The Stop command is active low. NOTE: Activated according to “AND” logic.
Enable	5	Enable command. General start condition to run the AC drive. If made low during running the output of the AC drive is cut off immediately, causing the motor to coast to zero speed. NOTE: If none of the digital inputs are programmed to “Enable”, the internal enable signal is active. NOTE: Activated according to “AND” logic.
RunR	6	Run Right command (positive speed). The output of the AC drive will be a clockwise rotary field.

RunL	7	Run Left command (negative speed). The output of the AC drive will be a counter-clockwise rotary field.
Ext. Trip2	8	Be aware that if there is nothing connected to the input, the AC drive will trip at “External trip” immediately. NOTE: The External Trip is active low. NOTE: Activated according to “AND” logic.
Reset	9	Reset command. To reset a Trip condition and to enable the Autoreset function.
Preset Ctrl1	10	To select the Preset Reference.
Preset Ctrl2	11	To select the Preset Reference.
Preset Ctrl3	12	To select the Preset Reference.
MotPot Up	13	Increases the internal reference value according to the set Acc MotPot time [333]. Has the same function as a “real” motor potentiometer, see Fig. 122.
MotPot Down	14	Decreases the internal reference value according to the set Dec MotPot time [334]. See MotPot Up.
Pump 1 Feedb	15	Feedback input pump1 for Pump/Fan control and informs about the status of the auxiliary connected pump/fan.
Pump 2 Feedb	16	Feedback input pump 2 for Pump/Fan control and informs about the status of the auxiliary connected pump/fan.
Pump 3 Feedb	17	Feedback input pump3 for Pump/Fan control and informs about the status of the auxiliary connected pump/fan.
Pump 4 Feedb	18	Feedback input pump 4 for Pump/Fan control and informs about the status of the auxiliary connected pump/fan.
Pump 5 Feedb	19	Feedback input pump5 for Pump/Fan control and informs about the status of the auxiliary connected pump/fan.
Pump 6 Feedb	20	Feedback input pump 6 for Pump/Fan control and informs about the status of the auxiliary connected pump/fan.
Ext. Trip3	21	Be aware that if there is nothing connected to the input, the AC drive will trip at “External trip” immediately. NOTE: The External Trip is active low. NOTE: Activated according to “AND” logic.
Ext. Trip4	22	Be aware that if there is nothing connected to the input, the AC drive will trip at “External trip” immediately. NOTE: The External Trip is active low. NOTE: Activated according to “AND” logic.
Set Ctrl 1	23	Activates other parameter set. See Table 37 for selection possibilities.
Set Ctrl 2	24	Activates other parameter set. See Table 37 for selection possibilities.
Mot PreMag	25	Pre-magnetises the motor. Used for faster motor start.

Jog	26	To activate the Jog function. Gives a Run command with the set Jog speed and Direction, page 145.
Ext Mot Temp	27	Be aware that if there is nothing connected to the input, the AC drive will trip at "External Motor Temp" immediately. NOTE: The External Motor Temp is active low.
Loc/Rem	28	Activate local mode defined in [2171] and [2172].
AnIn Select	29	Activate/deactivate analogue inputs defined in [513A], [516A], [519A] and [51CA]
LC Level	30	Liquid cooling low level signal. NOTE: The Liquid Cooling Level is active low.
Brk Ackn	31	Brake acknowledge input for Brake Fault control. Function is activated via this selection see menu [33H] page 142.
Sleep	32	Possible to enter sleep mode through Dign.
Timer 1	34	Timer 1 will be activated on the rising edge of this signal.
Timer 2	35	Timer 2 will be activated on the rising edge of this signal.
Timer 3	36	Timer 3 will be activated on the rising edge of this signal.
Timer 4	37	Timer 4 will be activated on the rising edge of this signal.
PumpClTrig	39	Requests a pump cleaning.
PumpCl Block	40	Blocks pump cleaning from starting.

---

**NOTE: To activate the parameter set selection, menu 241 must be set to Dign.**

---



---

**NOTE: For bipolar function, input RunR and RunL needs to be active and "Rotation [219]" must be set to "R+L".**

---

Table 37

Parameter Set	Set Ctrl 1	Set Ctrl 2
A	0	0
B	1	0
C	0	1
D	1	1

## Digital Input 2 [522] to Digital Input 8 [528]

Same function as “DigIn 1[521]”. Default function for DigIn 8 is Reset. For DigIn 3 to 7 the default function is Off.

522 DigIn 2	
Default:	RunR
Selection:	Same as in menu DigIn 1 [521]

## Additional digital inputs [529] to [52H]

529 B1 Digin 1	
Default:	Off
Selection:	Same as in menu DigIn 1 [521]

Additional digital inputs with I/O option board installed, “B1 DigIn 1 [529]” - “B3 DigIn 3 [52H]”. B stands for board and 1 to 3 is the number of the board which is related to the position of the I/O option board on the option mounting plate. The functions and selections are the same as “DigIn 1 [521]”.

## 11.5.3 Analogue Outputs [530]

Submenu with all settings for the analogue outputs. Selections can be made from application and AC drive values, in order to visualize actual status. Analogue outputs can also be used as a mirror of the analogue input. Such a signal can be used as:

- a reference signal for the next AC drive in a Master/Slave configuration (see Fig. 143).
- a feedback acknowledgement of the received analogue reference value.

### AnOut1 Function [531]

Sets the function for the Analogue Output 1. Scale and range are defined by AnOut1 Advanced settings [533].

531 AnOut1 Fc		
Default:		Speed
Process Val	0	Actual process value according to Process feedback signal.
Speed	1	Actual speed.
Torque	2	Actual torque.
Process Ref	3	Actual process reference value.
Shaft Power	4	Actual shaft power.
Frequency	5	Actual frequency.
Current	6	Actual current.
El power	7	Actual electrical power.
Output volt	8	Actual output voltage.
DC Voltage	9	Actual DC link voltage.
AnIn1	10	Mirror of received signal value on AnIn1.
AnIn2	11	Mirror of received signal value on AnIn2.
AnIn3	12	Mirror of received signal value on AnIn3.
AnIn4	13	Mirror of received signal value on AnIn4.
Speed Ref	14	Actual internal speed reference Value after ramp and V/Hz.
Torque Ref	15	Actual torque reference value (=0 in V/Hz mode)
AnMux1	16	Result of configured AnMux1 logical block, see [621].
AnMux2	17	Result of configured AnMux2 logical block, see [622].
IGBT Temp	18	Temperature of drive IGBT, see [71A].
PT100_1	20	Range 0-100 °C
PT100_2	21	Range 0-100 °C
PT100_3	22	Range 0-100 °C

**NOTE:** When selections AnIn1, AnIn2 .... AnIn4 is selected, the setup of the AnOut (menu [532] or [535]) has to be set to 0-10V or 0-20mA. When the AnOut Setup is set to e.g. 4-20mA, the mirroring is not working correct.

## AnOut 1 Setup [532]

Preset scaling and offset of the output configuration.

532 AnOut1 Setup		
Default:		4-20mA
4-20mA	0	The current output has a fixed threshold (Live Zero) of 4 mA and controls the full range for the output signal. See Fig. 140.
0-20mA	1	Normal full current scale configuration of the output that controls the full range for the output signal. See Fig. 139.
User mA	2	The scale of the current controlled output that controls the full range for the output signal. Can be defined by the advanced AnOut Min and AnOut Max menus.
User Bipol mA	3	Sets the output for a bipolar current output, where the scale controls the range for the output signal. Scale can be defined in advanced menu AnOut Bipol.
0-10V	4	Normal full voltage scale configuration of the output that controls the full range for the output signal. See Fig. 139.
2-10V	5	The voltage output has a fixed threshold (Live Zero) of 2 V and controls the full range for the output signal. See Fig. 140.
User V	6	The scale of the voltage controlled output that controls the full range for the output signal. Can be defined by the advanced AnOut Min and AnOut Max menus.
User Bipol V	7	Sets the output for a bipolar voltage output, where the scale controls the range for the output signal. Scale can be defined in advanced menu AnOut Bipol.

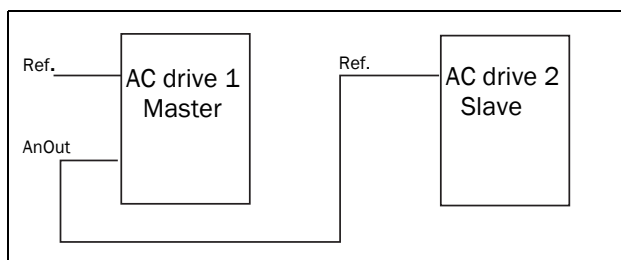

Fig. 143

## AnOut1 Advanced [533]

With the functions in the AnOut1 Advanced menu, the output can be completely defined according to the application needs. The menus will automatically be adapted to “mA” or “V”, according to the selection in “AnOut1 Setup [532]”.

### 533 AnOut 1 Advan

#### AnOut1 Min [5331]

This parameter is automatically displayed if User mA or User V is selected in menu “AnOut 1 Setup [532]”. The menu will automatically adapt to current or voltage setting according to the selected setup. Only visible if [532] = User mA/V.

### 5331 AnOut 1 Min

Default:	4 mA
Range:	0.00 – 20.00 mA, 0 – 10.00 V

#### AnOut1 Max [5332]

This parameter is automatically displayed if User mA or User V is selected in menu “AnOut1 Setup [532]”. The menu will automatically adapt to current or voltage setting according to the selected setup. Only visible if [532] = User mA/V.

### 5332 AnOut 1 Max

Default:	20.00 mA
Range:	0.00–20.00 mA, 0–10.00 V

#### AnOut1 Bipol [5333]

Automatically displayed if User Bipol mA or User Bipol V is selected in menu AnOut1 Setup. The menu will automatically show mA or V range according to the selected function. The range is set by changing the positive maximum value; the negative value is automatically adapted accordingly. Only visible if [512] = User Bipol mA/V.

### 5333 AnOut1Bipol

Default:	20mA
Range:	-10.00–10.00 V, -20.0–20.0 mA

### AnOut1 Function Min [5334]

With AnOut1 Function Min the physical minimum value is scaled to selected presentation. The default scaling is dependent of the selected function of “AnOut1 [531]”.

5334 AnOut1FcMin		
Default:		Min
Min	0	Min value
Max	1	Max value
User defined	2	Define user value in menu [5335]

Table 38 shows corresponding values for the min and max selections depending on the function of the analogue output [531].

Table 38

AnOut Function	Min Value	Max Value
Process Value	Process Min [324]	Process Max [325]
Speed	Min Speed [341]	Max Speed [343]
Torque	0%	Max Torque [351]
Process Ref	Process Min [324]	Process Max [325]
Shaft Power	0%	Motor Power [223]
Frequency	Fmin *	Motor Frequency [222]
Current	0 A	Motor Current [224]
EI Power	0 W	Motor Power [223]
Output Voltage	0 V	Motor Voltage [221]
DC voltage	0 V	1000 V
AnIn1	AnIn1 Function Min	AnIn1 Function Max
AnIn2	AnIn2 Function Min	AnIn2 Function Max
AnIn3	AnIn3 Function Min	AnIn3 Function Max
AnIn4	AnIn4 Function Min	AnIn4 Function Max

\*) Fmin is dependent on the set value in menu “Minimum Speed [341]”.

### Example

Set the AnOut function for Motorfrequency to 0Hz, set AnOut functionMin [5334] to “User-defined” and AnOut1 VaMin[5335] = 0.0. This results in an analogue output signal from 0/4 mA to 20mA: 0Hz to Fmot.

This principle is valid for all Min to Max settings.

### AnOut1 Function Value Min [5335]

With AnOut1 Function VaMin you define a user-defined value for the signal. Only visible when user-defined is selected in menu [5334].

5335 AnOut1VaMin	
Default:	0.000
Range:	-10000.000–10000.000

### AnOut1 Function Max [5336]

With AnOut1 Function Max the physical minimum value is scaled to selected presentation. The default scaling is dependent on the selected function of AnOut1 [531]. See Table 38.

5336 AnOut1FcMax		
Default:		Max
Min	0	Min value
Max	1	Max value
User defined	2	Define user value in menu [5337]

**NOTE:** It is possible to set AnOut1 up as an inverted output signal by setting AnOut1 Min > AnOut1 Max. See Fig. 141, page 173.

### AnOut1 Function Value Max [5337]

With AnOut1 Function VaMax you define a user-defined value for the signal. Only visible when user-defined is selected in menu [5334].

5337 AnOut1VaMax	
Default:	0.000
Range:	-10000.000–10000.000

### AnOut2 Function [534]

Sets the function for the Analogue Output 2.

534 AnOut2 Fc	
Default:	Torque
Selection:	Same as in menu [531]

## AnOut2 Setup [535]

Preset scaling and offset of the output configuration for analogue output 2.

535 AnOut2 Setup	
Default:	4-20mA
Selection:	Same as in menu [512]

## AnOut2 Advanced [536]

Same functions and submenus as under AnOut1 Advanced [533].

536 AnOut2 Advan	
------------------	--

## Analog Output Resolution [537]

Sets the number of decimals used for analog outputs.

## Analog Output Resolution on the Control Panel [5371]

Set the number of decimals presented by the control panel.

5371 CP ANOUT Resolution		
Default:	1%	
1%	0	No decimals
0.1%	1	One decimal
0.01%	2	Two decimals

## Analog Output Resolution in Communication [5372]

Set the number of decimals used by the communication interface.

5372 COM ANOUT Resolution		
Default:	1%	
1%	0	No decimals
0.1%	1	One decimal
0.01%	2	Two decimals

**NOTE:** The EINT-format limits the number of significant digits to three.

## 11.5.4 Digital Outputs [540]

Submenu with all the settings for the digital outputs.

## Digital Out 1 [541]

Sets the function for the digital output 1.

**NOTE:** The definitions described here are valid for the active output condition.

541 DigOut 1		
Default:	Ready	
Off	0	Output is not active and constantly low.
On	1	Output is made constantly high, i.e. for checking circuits and trouble shooting.
Run	2	Running. The AC drive output is active = produces current for the motor.
Stop	3	The AC drive output is not active.
0Hz	4	The output frequency=0±0.1Hz when in Run condition.
Acc/Dec	5	The speed is increasing or decreasing along the acc. ramp dec. ramp.
At Process	6	The output = Reference.
At Max spd	7	The frequency is limited by the Maximum Speed.
No Trip	8	No Trip condition active.
Trip	9	A Trip condition is active.
AutoRst Trip	10	Autoreset trip condition active.
Limit	11	A Limit condition is active.
Warning	12	A Warning condition is active.
Ready	13	The AC drive is ready for operation. This means that the AC drive is powered up and healthy.
$T = T_{lim}$	14	The torque is limited by the torque limit function.
$I > I_{nom}$	15	The output current is higher than the motor nominal current [224], reduced according to Motor ventilation [228], see Fig. 106, page 107.
Brake	16	The output is used to control a mechanical brake.
AnIn<Offset	17	One of the AnIn input signals is lower than 75% of the configured minimum value.
Alarm	18	The max or min alarm level has been reached.
Pre Alarm	19	The max or min pre alarm level has been reached.

Max Alarm	20	The max alarm level has been reached.
Max PreAlarm	21	The max pre alarm level has been reached.
Min Alarm	22	The min alarm level has been reached.
Min PreAlarm	23	The min pre alarm Level has been reached.
CA1	24	Analogue comparator 1 output.
CA2	25	Analogue comparator 2 output.
CA3	26	Analogue comparator 3 output.
CA4	27	Analogue comparator 4 output.
L1	28	Logic 1 expression output
L2	29	Logic 2 expression output
L3	30	Logic 3 expression output
L4	31	Logic 4 expression output
F1	32	Flip flop 1 output
F2	33	Flip flop 2 output
F3	34	Flip flop 3 output
F4	35	Flip flop 4 output
Operation	36	Run command is active or AC drive running. The signal can be used to control the mains contactor if the AC drive is equipped with Standby supply option.
T1Q	37	Timer 1 output
T2Q	38	Timer 2 output.
T3Q	39	Timer 3 output
T4Q	40	Timer 4 output
Sleeping	41	Sleeping function activated
Crane Deviat	42	Tripped on deviation
PumpSlave1	43	Activate pump slave 1
PumpSlave2	44	Activate pump slave 2
PumpSlave3	45	Activate pump slave 3
PumpSlave4	46	Activate pump slave 4
PumpSlave5	47	Activate pump slave 5
PumpSlave6	48	Activate pump slave 6
PumpMaster1	49	Activate pump master 1
PumpMaster2	50	Activate pump master 2
PumpMaster3	51	Activate pump master 3
PumpMaster4	52	Activate pump master 4
PumpMaster5	53	Activate pump master 5
PumpMaster6	54	Activate pump master 6
All Pumps	55	All pumps are running
Only Master	56	Only the master is running
Loc/Rem	57	Local/Rem mode indication Local = 1, Remote = 0

Standby	58	Standby supply option is active
PTC Trip	59	Trip when function is active
PT100 Trip	60	Trip when function is active
Overvolt	61	Overvoltage due to high main voltage
Overvolt G	62	Overvoltage due to generation mode
Overvolt D	63	Overvoltage due to deceleration
Acc	64	Acceleration along the acc. ramp
Dec	65	Deceleration along the dec. ramp
I <sup>2</sup> t	66	I <sup>2</sup> t limit protection active
V-Limit	67	Overvoltage limit function active
C-Limit	68	Overcurrent limit function active
Overtemp	69	Over temperature warning
Low voltage	70	Low voltage warning
DigIn 1	71	Digital input 1
DigIn 2	72	Digital input 2
DigIn 3	73	Digital input 3
DigIn 4	74	Digital input 4
DigIn 5	75	Digital input 5
DigIn 6	76	Digital input 6
DigIn 7	77	Digital input 7
DigIn 8	78	Digital input 8
ManRst Trip	79	Active trip that needs to be manually reset
Com Error	80	Serial communication lost
External Fan	81	The AC drive requires external cooling. Internal fans are active.
LC Pump	82	Activate liquid cooling pump
LC HE Fan	83	Activate liquid cooling heat exchanger fan
LC Level	84	Liquid cooling low level signal active
RunR	85	Positive speed (>0.5%), i.e. forward/clockwise direction.
RunL	86	Negative speed (<0.5%), i.e. reverse counter clockwise direction.
Com Active	87	Fieldbus communication active.
Brk Fault	88	Tripped on brake fault (not released)
BrkNotEngage	89	Warning and continued operation (keep torque) due to Brake not engaged during stop.
Option	90	Failure occurred in built-in option board.
NOT1	91	NOT gate 1 output
NOT2	92	NOT gate 2 output
NOT3	93	NOT gate 3 output
NOT4	94	NOT gate 4 output
NOT5	95	NOT gate 5 output

NOT6	96	NOT gate 6 output
NOT7	97	NOT gate 7 output
NOT8	98	NOT gate 8 output
CTR1	99	Counter 1 output
CTR2	100	Counter 2 output
CLK1	101	Clock logic 1 output
CLK2	102	Clock logic 2 output
Enc Error	103	Tripped on Encoder error
Crane Comm	104	Crane Communication lost
Spin Start	105	Spin start is active
kWh-Pulses	106	kWh pulses counter
STO Active	107	STO is active. The digital output reflects the signal reported to the control board, while the control board internally and PPU ignore the STO during power up, power down and standby.
ComFlt Set	109	Parameter set is changed in accordance with menu [246] due to a communication fault.
Option 1	111	Usage configurable by option software.
Option 2	112	Usage configurable by option software.
Option 3	113	Usage configurable by option software.
PumpClAct	114	Pump cleaning is active.
PumpClReq	115	Pump cleaning has been requested, but is not yet active.
B1 DigIn 1	116	Digital input 1 on I/O board #1 (option)
B1 DigIn 2	117	Digital input 2 on I/O board #1 (option)
B1 DigIn 3	118	Digital input 3 on I/O board #1 (option)
B2 DigIn 1	119	Digital input 1 on I/O board #2 (option)
B2 DigIn 2	120	Digital input 2 on I/O board #2 (option)
B2 DigIn 3	121	Digital input 3 on I/O board #2 (option)
B3 DigIn 1	122	Digital input 1 on I/O board #3 (option)
B3 DigIn 2	123	Digital input 2 on I/O board #3 (option)
B3 DigIn 3	124	Digital input 3 on I/O board #3 (option)
LVO Sleep	125	LVO sleep mode. Inverter is ready to apply power to the motor as soon as the supply voltage returns.

## Digital Out 2 [542]

**NOTE:** The definitions described here are valid for the active output condition.

Sets the function for the digital output 2.

<b>542</b>	<b>DigOut2</b>
Default:	Brake
Selection:	Same as in menu DigOut 1 [541].

## 11.5.5 Relays [550]

Submenu with all the settings for the relay outputs. The relay mode selection makes it possible to establish a “fail safe” relay operation by using the normal closed contact to function as the normal open contact.

---

**NOTE: Additional relays will become available when I/O option boards are connected. Maximum 3 boards with 3 relays each.**

---

### Relay 1 [551]

Sets the function for the relay output 1. Same function as digital output 1 [541] can be selected.

551 Relay 1	
Default:	Trip
Selection:	Same as in menu DigOut 1 [541].

### Relay 2 [552]

---

**NOTE: The definitions described here are valid for the active output condition.**

---

Sets the function for the relay output 2.

552 Relay 2	
Default:	Run
Selection:	Same as in menu DigOut 1 [541].

### Relay 3 [553]

Sets the function for the relay output 3.

553 Relay 3	
Default:	Off
Selection:	Same as in menu DigOut 1 [541].

## Board Relay [554] to [55C]

These additional relays are only visible if an I/O option board is fitted in slot 1, 2, or 3. The outputs are named B1 Relay 1–3, B2 Relay 1–3 and B3 Relay 1–3. B stands for board and 1–3 is the number of the board which is related to the position of the I/O option board on the option mounting plate. See menu DigOut 1 [541].

---

**NOTE: Visible only if optional board is detected or if any input/output is activated.**

---

## Relay Advanced [55D]

This function makes it possible to ensure that the relay will also be closed when the AC drive is malfunctioning or powered down.

### Example

A process always requires a certain minimum flow. To control the required number of pumps by the relay mode NC, the e.g. the pumps can be controlled normally by the pump control, but are also activated when the AC drive is tripped or powered down.

55D Relay Advan	
-----------------	--

### Relay 1 Mode [55D1]

55D1 Relay1 Mode		
Default:	N.O	
N.O	0	The normal open contact of the relay will be activated when the function is active.
N.C	1	The normally closed contact of the relay will act as a normal open contact. The contact will be opened when function is not active and closed when function is active.

### Relay Modes [55D2] to [55DC]

Same function as for “Relay 1 Mode [55D1]”.

## 11.5.6 Virtual Connections [560]

Functions to enable eight internal connections of comparator, timer and digital signals, without occupying physical digital in/outputs. Virtual connections are used to wireless connection of a digital output function to a digital input function. Available signals and control functions can be used to create your own specific functions.

### Example of start delay

The motor will start in RunR 10 seconds after DigIn1 gets high. DigIn1 has a time delay of 10 s.

Menu	Parameter	Setting
[521]	DigIn1	Timer 1
[561]	VIO 1 Dest	RunR
[562]	VIO 1 Source	T1Q
[641]	Timer1 Trig	DigIn 1
[642]	Timer1 Mode	Delay
[643]	Timer1 Delay	0:00:10

**NOTE: When a digital input and a virtual destination are set to the same function, this function will act as an OR logic function.**

## Virtual Connection 1 Destination [561]

With this function the destination of the virtual connection is established. When a function can be controlled by several sources, e.g. VC destination or Digital Input, the function will be controlled in conformity with "OR logic". See DigIn for descriptions of the different selections.

561 VIO 1 Dest	
Default:	Off
Selection:	Same selections as for Digital Input 1, menu [521].

## Virtual Connection 1 Source [562]

With this function the source of the virtual connection is defined. See DigOut 1 for description of the different selections.

562 VIO 1 Source	
Default:	Off
Selection:	Same as for menu [541].

## Virtual Connections 2-8 [563] to [56G]

Same function as virtual connection 1 [561] and [562].

## 11.6 Logical Functions and Timers [600]

With the Comparators, Logic Functions and Timers, conditional signals can be programmed for control or signalling features. This gives you the ability to compare different signals and values in order to generate monitoring/controlling features.

### 11.6.1 Comparators [610]

The comparators available make it possible to monitor different internal signals and values, and visualize via digital relay outputs, when a specific value or status is reached or established.

### Analogue comparators [611] - [614]

There are 4 analogue comparators that compare any available analogue value (including the analogue reference inputs) with two adjustable levels. The two levels available are Level HI and Level LO. There are two analogue comparator types selectable, an analogue comparator with hysteresis and an analogue window comparator.

The analogue hysteresis type comparator uses the two available levels to create a hysteresis for the comparator between setting and resetting the output. This function gives a clear difference in switching levels, which lets the process adapt until a certain action is started. With such a hysteresis, even an unstable analogue signal can be monitored without getting a nervous comparator output signal. Another feature is the possibility to get a fixed indication that a certain level has been passed. The comparator can latch by setting Level LO to a higher value than Level HI.

The analogue window comparator uses the two available levels to define the window in which the analogue value should be within for setting the comparator output. The input analogue value of the comparator can also be selected as bipolar, i.e. treated as signed value or unipolar, i.e. treated as absolute value.

Refer to Fig. 148, page 191 where these functions are illustrated.

## Analogue Comparator 1 Setup [611]

Analogue comparator 1, parameter group.

### Analogue Comparator 1 Value [6111]

Selection of the analogue value for Analogue Comparator 1 (CA1).

Analogue comparator 1 compares the selectable analogue value in menu [6111] with the constant Level HI in menu [6112] and constant Level LO in menu [6113]. If Bipolar type[6115] input signal is selected then the comparison is made with sign otherwise if unipolar selected then comparison is made with absolute values.

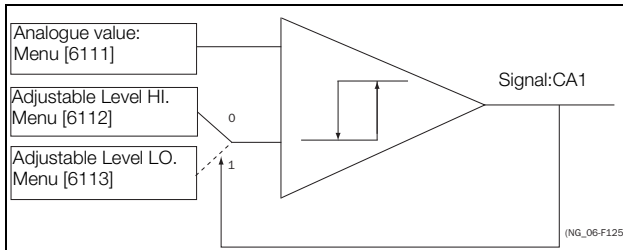

Fig. 144 Analogue comparator type Hysteresis

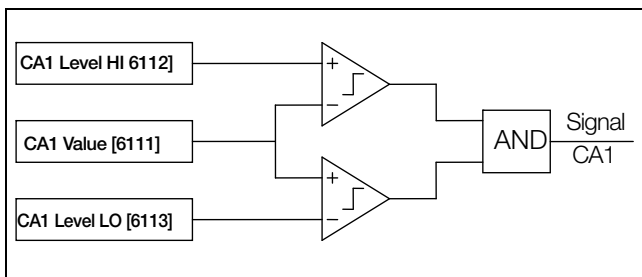

Fig. 145 Analogue comparator type "Window"

The output signal can be programmed as a virtual connection source and to the digital or relay outputs.

6111	CA1 Value	
Default:	Speed	
Process Val	0	Set by Process settings [321] and [322]
Speed	1	rpm
Torque	2	%
Shaft Power	3	kW
EI Power	4	kW
Current	5	A
Output volt	6	V
Frequency	7	Hz
DC Voltage	8	V
IGBT Temp	9	°C
PT100_1	10	°C
PT100_2	11	°C
PT100_3	12	°C
Energy	13	kWh
Run Time	14	h
Mains Time	15	h
AnIn1	16	%
AnIn2	17	%
AnIn3	18	%
AnIn4	19	%
Process Ref	20	Set by Process settings [321] and [322]
Process Err	21	
PT100_4	22	°C
PT100_5	23	°C
PT100_6	24	°C
AnMux1	25	%
AnMux2	26	%
Speed Ref	27	rpm
Torque Ref	28	%

## Example

Create automatic RUN/STOP signal via the analogue reference signal. Analogue current reference signal, 4-20 mA, is connected to Analogue Input 1. “AnIn1 Setup”, menu [512] = 4-20 mA and the threshold is 4 mA. Full scale (100%) input signal on “AnIn 1” = 20 mA. When the reference signal on “AnIn1” increases 80% of the threshold (4 mA x 0.8 = 3.2 mA), the AC drive will be set in RUN mode. When the signal on “AnIn1” goes below 60% of the threshold (4 mA x 0.6 = 2.4 mA) the AC drive is set to STOP mode. The output of CA1 is used as a virtual connection source that controls the virtual connection destination RUN.

Menu	Function	Setting
511	AnIn1 Function	Process reference
512	AnIn1 Set-up	4-20 mA, threshold is 4 mA
341	Min Speed	0
343	Max Speed	1500
6111	CA1 Value	AnIn1
6112	CA1 Level HI	16% (3.2mA/20mA x 100%)
6113	CA1 Level LO	12% (2.4mA/20mA x 100%)
6114	CA1 Type	Hysteresis
561	VIO 1 Dest	RunR
562	VIO 1 Source	CA1
215	Run/Stop Ctrl	Remote

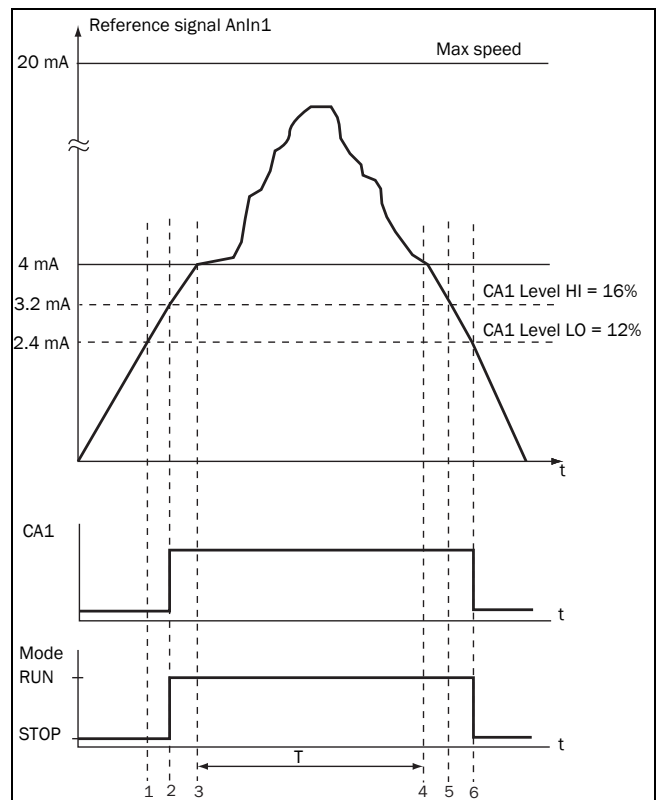

Fig. 146

No.	Description
1	The reference signal passes the Level LO value from below (positive edge), the comparator CA1 output stays low, mode=RUN.
2	The reference signal passes the Level HI value from below (positive edge), the comparator CA1 output is set high, mode=RUN.
3	The reference signal passes the threshold level of 4 mA, the motor speed will now follow the reference signal.
T	During this period the motor speed will follow the reference signal.
4	The reference signal reaches the threshold level, motor speed is 0 rpm, mode = RUN.
5	The reference signal passes the Level HI value from above (negative edge), the comparator CA1 output stays high, mode =RUN.
6	The reference signal passes the Level LO value from above (negative edge), the comparator CA1 output=STOP.

## Analogue Comparator 1, Level High [6112]

Sets the analogue comparator high level, with range according to the selected value in menu [6111].

6112 CA1 LevelHI	
Default:	300 rpm
Range:	See min/max in table below.

### Min/Max setting range for menu [6112]

Mode	Min	Max	Decimals
Process Val	Set by Process settings [321] and [322]		3
Speed, rpm	0	Max speed	0
Torque, %	0	Max torque	0
Shaft Power, kW	0	Motor $P_n \times 4$	0
El Power, kW	0	Motor $P_n \times 4$	0
Current, A	0	Motor $I_n \times 4$	1
Output volt, V	0	1000	1
Frequency, Hz	0	400	1
DC voltage, V	0	1250	1
IGBT temp, °C	0	100	1
PT 100_1_2_3, °C	-100	300	1
PT 100_4_5_6, °C	-100	300	1
Energy, kWh	0	1000000	0
Run time, h	0	65535	0
Mains time, h	0	65535	0
AnIn 1-4, %	0	100	0
AnMux 1-2, %	0	100	0
Process Ref	Set by Process settings [321] and [322]		3
Process Err	Set by Process settings [321] and [322]		3

**NOTE:** If Bipolar selected [6115] then Min value is equal to -Max in the table.

## Example

This example describes, both for hysteresis and window type comparator, the normal use of the constant level high and low.

Menu	Function	Setting
343	Max Speed	1500
561	VC1 Dest	Timer 1
562	VC1 Source	CA1
6111	CA1 Value	Speed
6112	CA1 Level HI	300 rpm
6113	CA1 Level LO	200 rpm
6114	CA1 Type	Hysteresis

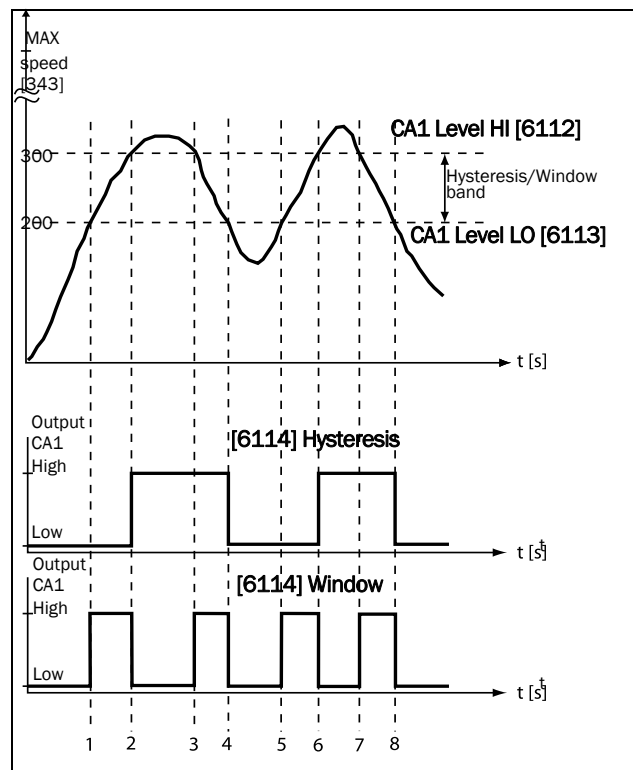

Fig. 147

Table 39 Comments to Fig. 147 regarding Hysteresis selection.

No.	Description	Hysteresis
1	The reference signal passes the Level LO value from below (positive edge), the comparator CA1 does not change, output stays low.	—
2	The reference signal passes the Level HI value from below (positive edge), the comparator CA1 output is set high.	↑
3	The reference signal passes the Level HI value from above (negative edge), the comparator CA1 does not change, output stays high.	—
4	The reference signal passes the Level LO value from above (negative edge), the comparator CA1 is reset, output is set low.	↓
5	The reference signal passes the Level LO value from below (positive edge), the comparator CA1 does not change, output stays low.	—
6	The reference signal passes the Level HI value from below (positive edge), the comparator CA1 output is set high.	↑
7	The reference signal passes the Level HI value from above (negative edge), the comparator CA1 does not change, output stays high.	—
8	The reference signal passes the Level LO value from above (negative edge), the comparator CA1 is reset, output is set low.	↓

Table 40 Comments to Fig. 147 regarding Window selection.

No.	Description	Window
1	The reference signal passes the Level LO value from below (signal inside Window band), the comparator CA1 output is set high.	↑
2	The reference signal passes the Level LO value from above (signal outside Window band), the comparator CA1 is reset, output is set low.	↓
3	The reference signal passes the Level HI value from above (signal inside Window band), the comparator CA1 output is set high.	↑
4	The reference signal passes the Level LO value from above (signal outside Window band), the comparator CA1 is reset, output is set low.	↓
5	The reference signal passes the Level LO value from below (signal inside Window band), the comparator CA1 output is set high.	↑
6	The reference signal passes the Level HI value from below (signal outside Window band), the comparator CA1 is reset, output is set low.	↓
7	The reference signal passes the Level HI value from above (signal inside Window band), the comparator CA1 output is set high.	↑
8	The reference signal passes the Level LO value from above (signal outside Window band), the comparator CA1 is reset, output is set low.	↓

### Analogue Comparator 1, Level Low [6113]

Sets the analogue comparator low level, with unit and range according to the selected value in menu [6111].

<b>6113</b>	<b>CA1 LevelLO</b>
Default:	200 rpm
Range:	Range as [6112].

### Analogue Comparator 1, Type [6114]

Selects the analogue comparator type, i.e. Hysteresis or Window type. See Fig. 148 and Fig. 149.

<b>6114</b>	<b>CA1 Type</b>
Default:	Hysteresis
Hysteresis	0 Hysteresis type comparator
Window	1 Window type comparator

### Analogue Comparator 1, Polarity [6115]

Selects how the selected value in [6111] should be handled prior to the analogue comparator, i.e. as absolute value or handled with sign. See Fig. 148

<b>6115</b>	<b>CA1 Polar</b>
Default:	Unipolar
Unipolar	0 Absolute value of [6111] used
Bipolar	1 Signed value of [6111] used

### Example

See Fig. 148 and Fig. 149 for different principle functionality of comparator features 6114 and 6115.

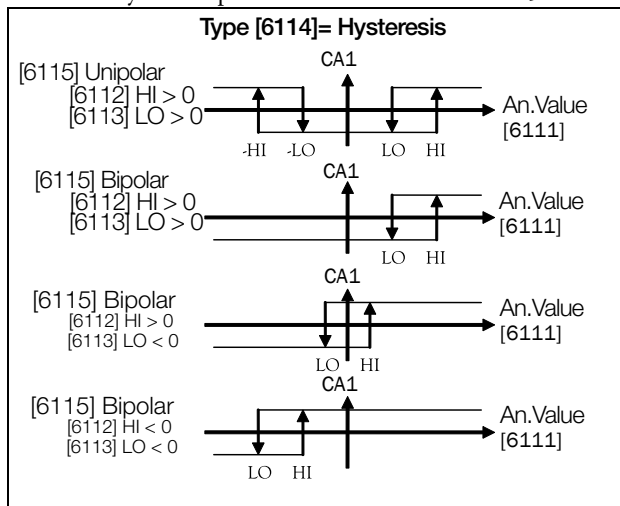

Fig. 148 Principle functionality of comparator features for "Type [6114] = Hysteresis" and "Polar [6115]".

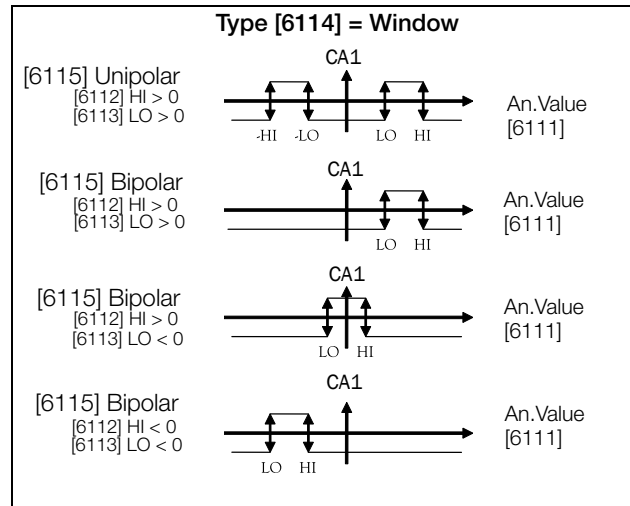

Fig. 149 Principle functionality of comparator features for "Type [6114] = Window" and "Polar [6115]".

**NOTE:** When "Unipolar" is selected, absolute value of signal is used.

**NOTE:** When "Bipolar" is selected in [6115] then:  
 1. Functionality is not symmetrical.  
 2. Ranges for high/low are bipolar

### Analogue Comparator 1 Set Delay [6116]

The output signal for the analogue comparator 1 is delayed with the set value in this menu. See Fig. 150.

<b>6116</b>	<b>CA1 Set Dly</b>
Default:	0 s
Range:	0 - 36000 s

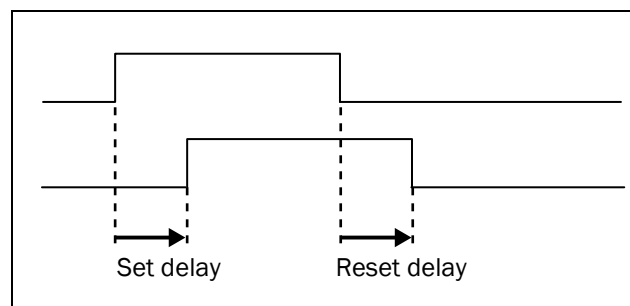

Fig. 150 Set/reset delay for output signal.

## Analogue Comparator 1 Reset Delay [6117]

The reset of the output signal for the analogue comparator 1 is delayed with the set time in this menu. See Fig. 150.

6117 CA1 Res Dly	
Default:	0 s
Range:	0 - 36000 s

## Analogue Comparator 1 Timer Value [6118]

The actual timer value for analogue comparator 1 is viewed in this menu.

6118 CA1 Tmr Val	
Default:	0 s
Range:	0 - 36000 s

## Setup Analogue Comparators 2-4 [612] - [614]

Refer to the descriptions for Analogue Comparator 1. See Chapter 15, page 251 regarding defaults.

## 11.6.2 Analogue Multiplexer [620]

The Analogue Mux compares two configurable analogue input signals (InA and InB) and generates a virtual analogue output. Output behavior depends on the configured operator. Output can be used as source for analogue output or input value to analogue comparators.

Since both input and output is limited to range -100% to 100% some operations might overflow. Result is always limited within the range. Consequently some operators have a "divided by 2" variant to always produce overflow safe variants (result is always within the range).

### Analogue Multiplexer 1 [621]

#### AnMux1 InA [6211]

First input to the AnMux1. Select one of AnIn1 - 4.

6211 AnMux1 InA		
Default:	AnIn1	
AnIn1	0	%
AnIn2	1	%
AnIn3	2	%
AnIn4	3	%

#### AnMux1 InB [6212]

Second input to AnMux1. Select one of AnIn1 - 4.

6212 AnMux1 InB		
Default:	AnIn2	
AnIn1	0	%
AnIn2	1	%
AnIn3	2	%
AnIn4	3	%

## Analogue Multiplexer 1 Operator [6213]

Operator of the Analogue Mux 1. The names shown on the control panel will be changed according to the following.

<b>6213 AnMux1 Op</b>		
Default:		Off
Off	0	No output
MIN(A,B)	1	Minimal value of InA and InB
MAX(A,B)	2	Max value of InA and InB
A+B	3	Sum of InA and InB
(A+B)/2	4	Sum of InA and InB that is overflow safe
A-B	5	Difference of InA and InB
(A-B)/2	6	Difference of InA and InB that is overflow safe
B-A	7	Difference of InB and InA
(B-A)/2	8	Difference of InB and InA that is overflow safe
ABS(A-B)	9	Absolute value of difference of InA and InB.
ABS(A-B)/2	10	Absolute value of difference of InA and InB that is overflow safe

## Analogue Multiplexer 2 Operator [6223]

Operator of the Analogue Mux 2. The function is the same as in Operator [6213].

<b>6223 AnMux2 Op</b>	
Default:	Off
Selections:	Same as in menu Operator [6213].

## Analogue Multiplexer 2 [622]

The same function as in Analog Mux1 [621].

### AnMux2 InA [6221]

The function is the same as in Analogue Mux InA value [6211].

<b>6221 AnMux2 InA</b>		
Default:		AnIn1
AnIn1	0	%
AnIn2	1	%
AnIn3	2	%
AnIn4	3	%

### AnMux2 InB [6222]

The function is the same as in Analogue Mux InB value [6212].

<b>6222 AnMux2 InB</b>		
Default:		AnIn2
AnIn1	0	%
AnIn2	1	%
AnIn3	2	%
AnIn4	3	%

### 11.6.3 Not Gate [630]

Output of the NOT gate is the inverted signal of the selected input. NOT gates are used when some other function (logic expression, digital out, virtual IO) needs the inverted signal.

#### NOT1 Input [631]

<b>631 NOT1 Input</b>	
Default:	CA2
Selection:	Same as in menu DigOut 1 [541].

#### NOT2 Input [632] - NOT8 Input [638]

Refer to the descriptions for NOT1 Input [631]. For default values see Chapter 15, page 251.

### 11.6.4 Logic output [640]

#### Logic Output 1 [641]

By means of an expression editor, the input signals can be logically combined into the logics function to create a logic output signal.

The expression editor has the following features:

- All available digital output signals can be used as input to the logic block.
- The following logical operators are available:
  - "+" : OR operator
  - "&" : AND operator
  - "^" : EXOR operator
  - "." : This close the expression

Expressions according to the following truth table can be made (see also the example below):

Input		Result		
A	B	& (AND)	+ (OR)	^(EXOR)
0	0	0	0	0
0	1	0	1	1
1	0	0	1	1
1	1	1	1	0

The output signal can be programmed to the relay outputs or used as a virtual connection source [560].

The logic expression must be programmed by means of the menus [6411] to [641B], and its actual appearance can be viewed in menu [641], with example below:

<b>641</b>	<b>0rpm</b>
<b>Logic 1</b>	
	<b>((0&amp;1) &amp;0) &amp;1</b>
<b>Sby</b> <b>A</b>	<b>Rem/Rem</b>

Menu [641] shows the actual values of the four selected input signals set in menus [6412], [6414], [6416] and [6418].

## Logic 1 Expression [6411]

Selection of execution order of the logic expression for the Logic 1 function:

6411 L1 Expr		
Default:		((1.2).3).4
((1.2).3).4	0	Default execution order, see explanation below.
(1.2).(3.4)	1	Alternative execution order, see explanation below.

- Parentheses ( ) show the order in which the Logic 1 Inputs are combined, according to [6411].
- 1, 2, 3, and 4, represent the Logic 1 Input signals selected in menu [6412], [6414], [6416], and [6418].
- The dots stand for the Logic 1 Operators (&, +, or ^), whose values are selected in menus [6413], [6415], and [6417].

To build the Logic 1 expression using the default selection in menu [6411], the execution order is as follows:

1. Input 1 is combined with Input 2 using Operator 1.
2. Input 3 is combined with the expression (1.2), using Operator 2.
3. Input 4 is combined with the result of (1.2).3, using Operator 3.

The alternative execution order leads to:

1. Input 1 is combined with Input 2 using Operator 1.
2. Input 3 is combined with Input 4 using Operator 3.
3. Expression (1.2) is combined with expression (3.4), using Operator 2.

### Example

Input 1 [6412]

Input 2 = F1, menu [6414]

Input 3 = T1Q, menu [6416]

Input 4 = NOT1, menu [631]

In case NOT1 is configured to CA2 the output of the NOT1 gate will be the inverse of CA2 i.e. !CA2.

Operator 1 = & (AND), set in menu [6413]

Operator 2 = + (OR), menu [6415]

Operator 3 = & (AND), menu [6417]

The following expression is created, using the menus above:

$$CA1 \& F1 + T1Q \& NOT1$$

With the default setting for L1 Expression this is representing:

$$((CA1 \& F1) + T1Q) \& NOT1$$

Let's use the following values on the input signals as an example:

CA1 = 1 (active/high)

F1 = 1 (active/high)

T1Q = 1 (active/high)

NOT1 = 0 (inactive/low)

With the respective values inserted the resulting logic expression is:

641 L1 Expr	
Logic 1	Orpm
Sby <input checked="" type="checkbox"/>	((1&1)+1) & 0 Rem/Rem

which is equal to 0.

With the alternative execution order for the L1 Expression this is representing:

$$(CA1 \& F1) + (T1Q \& NOT1)$$

With the above values inserted the resulting logic expression now becomes:

641 L1 Expr	
Logic 1	Orpm
Sby <input checked="" type="checkbox"/>	(1&1) + (1&0) Rem/Rem

which is equal to 1.

### Logic 1 Input 1 [6412]

In this menu the first input for the Logic 1 function is selected. The same selections are valid for [6414] L1 Input 2, [6416] L1 Input 3, and [6418] L1 Input 4. See Chapter 15, page 251.

6412 L1 Input 1	
Default:	CA1
Selection:	Same as in menu DigOut 1 [541].

### Logic 1 Operator 1 [6413]

In this menu the first operator for the Logic 1 function is selected.

6413 L1 Op 1		
Default:	&	
.	0	When . (dot) is selected, the Logic 1 expression is finished (when two or three expressions are tied together).
&	1	&=AND
+	2	+=OR
^	3	^=EXOR

### Logic 1 Input 2 [6414]

In this menu the second input for the Logic 1 function is selected.

6414 L1 Input 2	
Default:	NOT1
Selection:	Same as in menu DigOut 1 [541].

### Logic 1 Operator 2 [6415]

In this menu the second operator for the Logic 1 function is selected.

6415 L1 Op 2	
Default:	&
Selection:	Same as in menu L1 Op 1 [6413].

### Logic 1 Input 3 [6416]

In this menu the third input for the Logic 1 function is selected.

6416 L1 Input 3	
Default:	Run
Selection:	Same as in menu DigOut 1 [541].

### Logic 1 Operator 3 [6417]

In this menu the third operator for the Logic 1 function is selected.

6417 L1 Op 3	
Default:	.
Selection:	Same as in menu L1 Op 1 [6413].

### Logic 1 Input 4 [6418]

In this menu the fourth input for the Logic 1 function is selected.

6418 L1 Input 4	
Default:	Off
Selection:	Same as in menu DigOut 1 [541].

### Logic 1 Set Delay [6419]

The activation of the output signal for the Logic 1 function is delayed with the set value in this menu. Compare to Chapter Fig. 150 page 191.

6419 L1 Set Dly	
Default:	0.0 s
Range:	0 - 36000.0 s

### Logic 1 Reset Delay [641A]

The reset of the output signal for the Logic 1 function is delayed with the set value in this menu. Compare to Chapter Fig. 150 page 191.

641A L1 Res Dly	
Default:	0.0 s
Range:	0 - 36000.0 s

### Logic 1 Timer Value [641B]

The actual timer value for logic 1 is viewed in this menu.

641B L1 Tmr Val	
Default:	0.0 s
Range:	0 - 36000.0 s

### Logic 2 - 4 [642] - [644]

Refer to the descriptions for Logic 1. For default values see Chapter 15, page 251.

## 11.6.5 Timers [650]

The Timer functions can be used as a delay timer or as an interval with separate “on” and “off” times (alternate mode), or as a way to prolong a signal (on-time mode). The selected trigger signal starts the timer function, and the signal is converted according to the mode settings, resulting in the timer output signal (T1Q - T4Q). In “Delay” mode, the output signal T1Q becomes high if the set delay time is expired. See Fig. 151.

In “Delay” mode, the activation of the timer output signal will be delayed in comparison to the trigger signal. The timer output signal is activated (high) when the set delay time has expired. See Fig. 151. The timer output signal will however follow the trigger signal when this is deactivated (low) again.

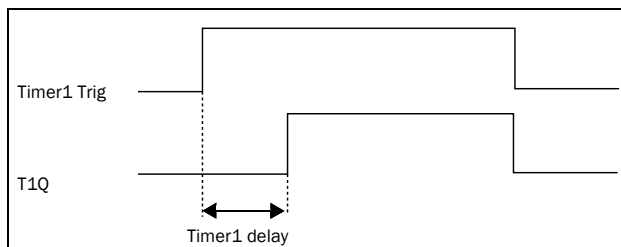

Fig. 151 Delay timer mode.

In alternate mode, the output signal T1Q will switch automatically from high to low etc. according to the set interval times “Timer1 T1” and “Timer 1 T2”. See Fig. 152.

The output signal can be programmed to the digital or relay outputs used in logic functions [600] or as a virtual connection source [560].

---

**NOTE: The actual timers are common for all parameter sets. If the actual set is changed, the timer functionality [641] to [645] will change according set settings but the timer value will stay unchanged. So initialization of the timer might differ for a set change compared to normal triggering of a timer.**

---

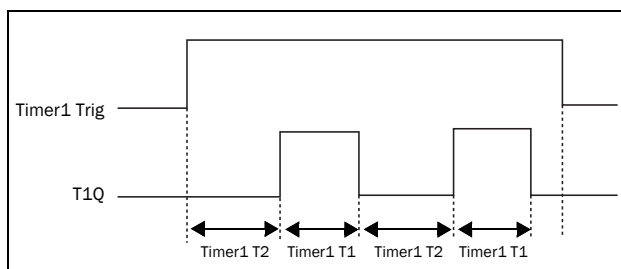

Fig. 152 Alternative timer mode

The function of the “On-time” mode is to extend an activated (high) timer output signal in comparison to the trigger signal. See Fig. 153.

- Output goes high when in signal goes high (positive edge triggered)
- Output stays high for configured time.
- If new positive edge is detected during configured on-time the elapsed time is reset.
- In case the in signal stays high longer than configured time output is kept high as long as in signal is active.

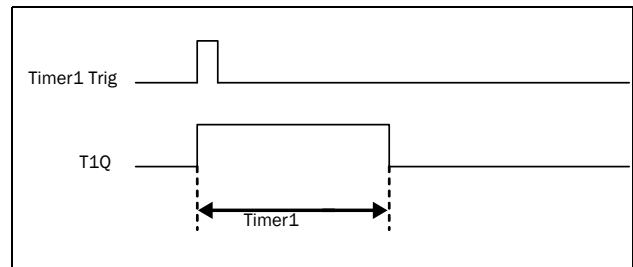

Fig. 153 On-time timer mode.

The timer output signals (T1Q - T4Q) can be programmed to the relay outputs used in logic functions [620], or be used as a virtual connection source [560].

---

**NOTE: The actual timers are common for all parameter sets. If the actual parameter set is changed, the timer functionality will change according to the settings, but the timer value will stay unchanged. So initialisation of the timer might differ for a set change compared to normal triggering of a timer.**

---

## Timer 1 [651]

Parameter group for Timer 1.

### Timer 1 Trig [6511]

Selection of the Timer input trigger signal

Timer 1 can be activated by a high signal on a DigIn that is set to Timer 1 or via a virtual destination [560].

6511 Timer1 Trig	
Default:	Off
Selection:	Same as in menu DigOut 1 [541].

### Timer 1 Mode [6512]

Selection of mode of operation for Timer 1.

6512 Timer1 Mode		
Default:	Off	
Off	0	Timer is disabled
Delay	1	Output signal will be delayed in comparison to the trigger signal.
Alternate	2	Timer output will automatically keep on switching according to the independently programmable on and off times as long as it is triggered.
On-time	3	Timer output will extend the trigger signal according to configured on-time.

### Timer1 T1/Delay [6514]

This menu is only visible when timer mode is active (not off). If the timer mode is delay, then this menu sets the timer delay. It sets the timer time in other timer modes. This menu can only be edited as described in manuals 01-7491-0Xr2 for FDU 2.1 and 01-7492-0Xr2 for VFX 2.1 (see "Chapter 10. Operating via the Control Panel", Section 10.5 "Editing values in a menu", alternative 2).

6514 Timer1 T1/D	
Default:	0.0 s
Range:	0 - 36000.0 s

## Timer 1 T2 [6515]

Timer 1 T2 sets the off time in the alternate mode.

6515 Timer1 T2	
Default:	0.0 s
Range:	0 - 36000.0 s

NOTE: "Timer 1 T1 [6514]" and "Timer 1 T2 [6515]" are only visible when Timer Mode is set to Alternate.

## Timer 1 Actual Value [6516]

Timer 1 Value shows actual value of the timer.

6516 Timer1Value	
Default:	0.0 s
Range:	0 - 36000.0 s

## Timer 2 - Timer 4 [652] - [654]

Refer to the description for Timer 1 [651].

## 11.6.6 Flip flops [660]

The flip-flop function is a memory circuit that can be used to store data concerning state. The output from a flip-flop is dependent not only on its current input, but also on its state at the moment this is received (hence previous input status also matters).

The set/reset flip-flop circuit has two input signals, SET and RESET, that control the state of an output signal, OUT.

When none of the input signals are active (i.e. both are =0), the flip-flop will keep its current value. Changes of the flip-flop state always occur on the rising edge of one of its inputs.

When only one of the input signals becomes active (=1), this will directly decide the status of the output signal.

Consequently if SET becomes active and RESET is inactive, the SET command is given to the output signal, OUT. This will result in a signal change from inactive to active (=1), if not already in an active state.

Conversely, if SET is inactive and RESET becomes active, the RESET command is given to the output signal, OUT, causing this to be deactivated (=0).

When both of the inputs signals becomes active the resulting operation depends on the configured Flip-flop priority mode as explained below.

### Flip-flop priority mode

When both input signals becomes active simultaneously, i.e. both SET and RESET are =1, a priority function decides which signal will influence the output signal. There are three different priority settings available for the flip-flop function, selected in the menu for "Flip-flop Mode". Examples of the different priority settings are presented in Fig. 154.

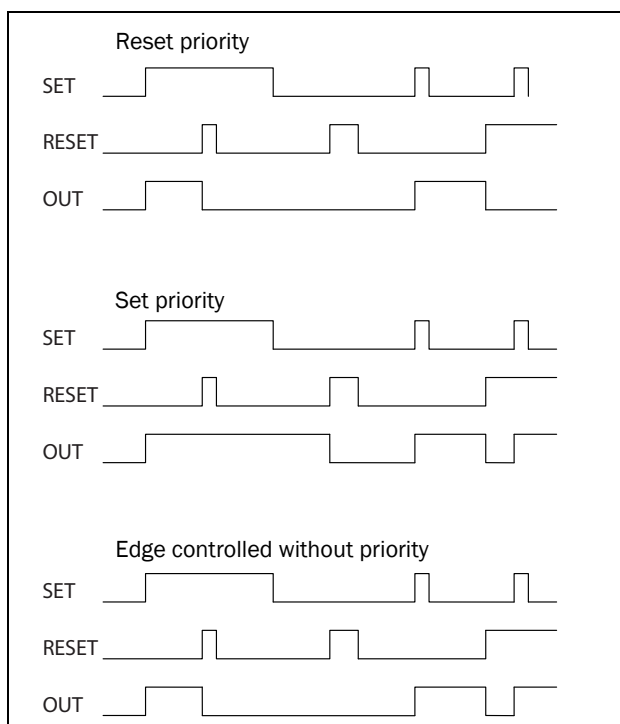

Fig. 154 Programmable flip-flop modes.

### Reset priority

"Reset priority" means that if both input signals becomes active, it will be the RESET command that is obeyed, causing the output signal to become inactive (=0) on the rising edge of RESET, as can be seen in Fig. 154. If RESET comes first OUT remain inactive when later SET signal becomes active. If SET comes first OUT will turn inactive upon the rising edge of RESET.

### Set priority

For "Set priority" the determining input signal is SET. Should both input signals become active, this is resulting in an activated (=1) output signal on the rising edge of SET, as can be seen in Fig. 154. If SET comes first OUT will remain active when later RESET signal becomes active. If RESET comes first OUT will turn active upon the rising edge of SET.

### Edge controlled without priority

The third setting is "Edge controlled", for which no input signal has priority over the other. The output signal follows any of the two input signals (still providing they are at a positive edge). The most recent registered activity decides the output. See Table 41.

Should both inputs become activated simultaneously, there will not be any change; the output signal will just keep its earlier status.

**NOTE: The input signals are updated in intervals of 8 milliseconds, therefore the signal changes are considered simultaneous if the difference is less than 8 ms.**

Table 41 Truth table for Edge control without priority.

SET	RESET	OUT
0	0	- (no change)
↗1	0/1	1 (set)
0/1	↗1	0 (reset)
↗1	↗1	No change

## Flip flop 1 [661]

Function for SR flip-flop 1.

### Flip flop 1 mode [6611]

Priority setting of input signals for flip-flop 1.

6611 F1 mode		
Default:		Reset
Reset	0	Reset priority.
Set	1	Set priority.
Edge	2	Edge controlled without priority.

### Flip flop 1 set [6612]

Selection of SET input signal for flip-flop 1.

6612 F1 set	
Default:	Off
Selection:	Same as in menu DigOut 1 [541].

### Flip flop 1 reset [6613]

Selection of RESET input signals for flip-flop 1.

6613 F1 reset	
Default:	Off
Selection:	Same as in menu DigOut 1 [541].

### Flip flop 1 set delay [6614]

The SET input signal for flip-flop 1 is delayed with the set value in this menu.

6614 F1 Set Dly	
Default:	0.0 s
Selection:	0 - 36000.0 s

### Flip flop 1 reset delay [6615]

The RESET input signal for flip-flop 1 is delayed with the set value in this menu.

6615 F1 Res Dly	
Default:	0.0 s
Selection:	0 - 36000.0 s

### Flip flop 1 timer value [6616]

This menu shows the actual value of the flip flop 1 timer.

6616 F1 Tmr Val	
Default:	0.0 s
Selection:	0 - 36000.0 s

## Flip flop 2 - 4 [662] - [664]

Refer to the description for Flip Flop 1[661].

## 11.6.7 Counters [670]

Counter functions for counting pulses and signalling on digital output when counter reaches specified high and low limit levels.

The counter is counting up on positive flanks on the triggered signal, the counter is cleared as long as the Reset signal is active.

The counter can be automatically decremented with specified decrement time, if no new trigger signal has occurred within the decrement time.

The counter value is clamped to the high limit value and the digital output function (CTR1 or CTR2) is active when counter value equals high limit value.

See Fig. 155 for more information of the counters.

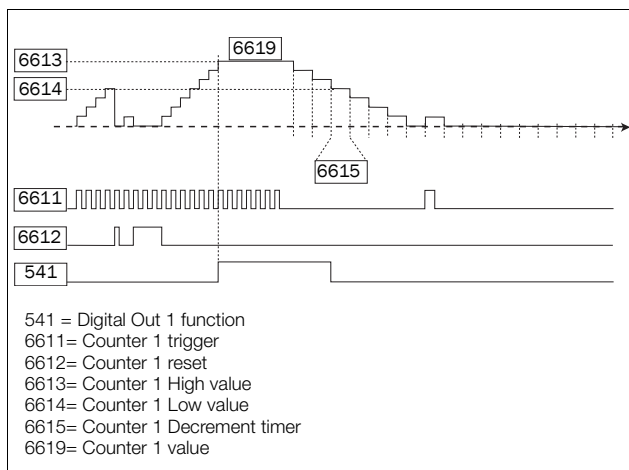

Fig. 155 Counters, operating principle.

### Counter1 [671]

Counter 1 parameter group.

#### Counter 1 Trigger [6711]

Selection of the digital output signal used as trigger signal for counter 1. Counter 1 is incremented by 1 on every positive flank on the trigger signal.

**NOTE: Maximum counting frequency is 8 Hz.**

6711	C1 Trig
Default:	Off
Selection:	Same as in menu DigOut 1 [541].

#### Counter 1 Reset [6712]

Selection of the digital signal used as reset signal for counter 1. Counter 1 is cleared to 0 and held to 0 as long as reset input is active (high).

**NOTE: Reset input has top priority.**

6712	C1 Reset
Default:	Off
Selection:	Same as in menu DigOut 1 [541].

#### Counter 1 High value [6713]

Sets counter 1 high limit value. Counter 1 value is clamped to selected high limit value and the counter 1 output (CTR1) is active (high) when the counter value equals the high value.

**NOTE: Value 0 means that counter output is always true (high).**

6713	C1 High Val
Default:	0
Range:	0 - 10000

#### Counter 1 Low value [6714]

Sets counter 1 low limit value. Counter 1 output (CTR1) is de-activated (low) when the counter value is equal or smaller than the low value.

**NOTE: Counter high value has priority so if high and low values are equal then the counter output is de-activated when the value is smaller than the low value.**

6714	C1 Low Val
Default:	0
Range:	0 - 10000

#### Counter 1 Decrement timer [6715]

Sets counter 1 automatic decrement timer value. The counter 1 is decremented by 1 after elapsed decrement time and if no new trigger has happened within the decrement time. The decrement timer is reset to 0 at every counter 1 trig pulse.

6715	C1 DecTimer
Default:	Off
Range:	Off, 1–3600 s (Off=0)

### Counter 1 Value [6719]

Parameter shows the actual value of counter 1.

---

<b>NOTE: Counter 1 value is common for all parameter sets.</b>	
<b>NOTE: The value is volatile and lost at power down.</b>	

---

<b>6719 C1 Value</b>	
Default:	0
Range:	0 - 10000

### Counter2 [672]

Refer to description for Counter 1 [671].

### Counter 2 Trigger [6721]

Function is identical to Counter 1 Trigger [6711].

<b>6721 C2 Trig</b>	
Default:	Off
Selection:	Same as in menu DigOut 1 [541].

### Counter 2 Reset [6722]

Function is identical to Counter 1 Reset [6712].

<b>6722 C2 Reset</b>	
Default:	Off
Selection:	Same as in menu DigOut 1 [541].

### Counter 2 High value [6723]

Function is identical to Counter 1 High value [6713].

<b>6723 C2 High Val</b>	
Default:	0
Range:	0 - 10000

### Counter 2 Low value [6724]

Function is identical to Counter 1 Low value [6714].

<b>6724 C2 Low Val</b>	
Default:	0
Range:	0 - 10000

### Counter 2 Decrement timer [6725]

Function is identical to Counter 1 Decrement timer [6715].

<b>6725 C2 DecTimer</b>		
Default:		Off
Range:		Off, 1–3600 s (Off=0)

### Counter 2 Value [6729]

Parameter shows the actual value of counter 2.

---

<b>NOTE: Counter 2 value is common for all parameter sets.</b>	
<b>NOTE: The value is volatile and lost at power down.</b>	

---

<b>6729 C2 Value</b>	
Default:	0
Range:	0 - 10000

## 11.6.8 Clock Logic [680]

Group 670 if only available if the drive is equipped with a 4-line type Control panel (incl. RTC).

There are two Clock functions, Clock 1 and Clock 2. Each clock with separate settings for Time on, Time Off, Date on, Date Off and Weekday. These clocks can be used for activating/deactivating desired functions via Relay, digital output or Virtual I/O (For example creating start and stop commands).

### Clock 1 [681]

The time, date and weekday for clock 1 are set in these submenus.

<b>681</b>	<b>Clock 1</b>
------------	----------------

#### Clock 1 Time On [6811]

Time when the clock 1 output signal (CLK1) is activated.

<b>6811</b>	<b>Clk1TimeON</b>
Default:	00:00:00 (hh:mm:ss)
Range:	0:00:00–23:59:59

#### Clock 1 Time Off [6812]

Time when the clock 1 output signal (CLK1) is deactivated.

<b>6812</b>	<b>Clk1TimeOff</b>
Default:	00:00:00 (hh:mm:ss)
Range:	0:00:00–23:59:59

#### Clock 1 Date On [6813]

Date when the clock 1 output signal (CLK1) is activated.

<b>6813</b>	<b>Clk1DateOn</b>
Default:	2000-00-00
Range:	yyyy-mm-dd (year-month-day)

#### Clock 1 Date Off [6814]

Date when the clock output signal (CLK1) is deactivated. Note that if “Clk1DateOff” is set to an earlier date than “Clk1DateOn”, the result will be that the clock is not deactivated at the set date.

<b>6814</b>	<b>Clk1DateOff</b>
Default:	2000-00-00
Range:	yyyy-mm-dd (year-month-day)

### Clock 1 Weekday [6815]

Weekdays when the clock function is active. Having entered the editing mode, select or unselect the desired weekdays with the cursor using the PREV and NEXT keys on the control panel. Confirm by pressing ENTER. Exit the editing mode and the activated weekdays will be viewed in the menu display. The deactivated weekdays are replaced by a dash mark “-” (e.g. “MTWTF - -”).

<b>6815</b>	<b>Clk1Weekday</b>
Default:	MTWTFSS (all activated)
Range:	Monday, Tuesday, Wednesday, Thursday, Friday, Saturday, Sunday.

**NOTE: Please make sure that the correct time and date settings are done for the real time clock, menu group [930] “Clock”.**

Example 1:

The output CLK1 shall be active Mondays to Fridays on working hours, e.g. 08:00-17:00. This signal is used to start e.g. a fan with virtual I/O.

Menu	Text	Setting
6811	Clk1TimeOn	08:00
6812	Clk1TimeOff	17:00
6813	Clk1DateOn	2017-02-01 (date in the past)
6814	Clk1DateOff	2099-12-31 (Date in the future)
6815	Clk1Weekday	MTWTF- -
561	VIO 1 Dest	Run FWD
562	VIO 1 Source	Clk1

Example 2:

The output CLK1 shall be active on weekends, all day.

Menu	Text	Setting
6811	Clk1TimeOn	0:00:00
6812	Clk1TimeOff	23:59:59
6813	Clk1DateOn	2017-02-01 (date in the past)
6814	Clk1DateOff	2099-12-31 (Date in the future)
6815	Clk1Weekday	- - - - - SS
561	VIO 1 Dest	Run FWD
562	VIO 1 Source	Clk1

### Clock 2 [682]

Refer to the description for Clock 1 [681].

## 11.7 View Operation/Status [700]

Menu with parameters for viewing all actual operational data, such as speed, torque, power, etc.

### 11.7.1 Operation [710]

#### Process Value [711]

The process value is showing the process actual value, depending on selection done in chapter, Process Source [321].

711 Process Val	
Unit:	Depends on selected Process source [321] and Process Unit [322].
Resolution:	Speed: 1 rpm, 4 digits Other units: 3 digits

#### Speed [712]

Displays the actual shaft speed.

712 Speed	
Unit:	rpm
Resolution:	1 rpm, 4 digits

**NOTE:** If accessed via communication, the signal is unreliable at speeds outside -32768 ... 32767.

#### Torque [713]

Displays the actual shaft torque.

713 Torque	
Unit:	%, Nm
Resolution:	1 %, 0.1 Nm

#### Shaft power [714]

Displays the actual shaft power. Negative sign is used when the shaft is generating mechanical power to the motor.

714 Shaft Power	
Unit:	W
Resolution:	1W

#### Electrical Power [715]

Displays the actual electrical output power. Negative sign is used when the motor is generating electrical power to the drive unit.

715 El Power	
Unit:	kW
Resolution:	1 W

#### Current [716]

Displays the actual output current.

716 Current	
Unit:	A
Resolution:	0.1 A

#### Output Voltage [717]

Displays the actual output voltage.

717 Output volt	
Unit:	V
Resolution:	0.1 V

#### Frequency [718]

Displays the actual output frequency.

718 Frequency	
Unit:	Hz
Resolution:	0.1 Hz

#### DC Link Voltage [719]

Displays the actual DC link voltage.

719 DC Voltage	
Unit:	V
Resolution:	0.1 V

## IGBT Temperature [71A]

Displays the actual IGBT temperature, measured. The signal is generated by a sensor in the IGBT module.

<b>71A</b>	<b>IGBT Temp</b>
Unit:	°C
Resolution:	0.1°C

\* The IGBT losses and temperature depend on the actual operation condition, i.e. output current and voltage, DC-voltage, switching frequency and cooling. At high temperatures, the switching frequency is reduced down to minimum 1.5 kHz to avoid trip due to over-temperature. This feature provides for continuous and trouble free operation of the drive even with high IGBT temperatures.

## PT100\_1\_2\_3 Temperature [71B]

Displays the actual PT100 temperature, for PT100 board 1.

<b>71B</b>	<b>PT100 1, 2, 3</b>
Unit:	°C
Resolution:	1°C

## PT100\_4\_5\_6 Temperature [71C]

Displays the actual PT100 temperature, for PT100 board 2.

<b>71C</b>	<b>PT100 4, 5, 6</b>
Unit:	°C
Resolution:	1°C

## 11.7.2 Status [720]

### Frequency Inverter Status [721]

Indicates the overall status of the AC drive.

<b>721</b>	<b>0rpm</b>
<b>VSD Status</b>	<b>1/222/333/44</b>
<b>Sby</b>	<b>Rem/Rem</b>

Fig. 156 AC drive status

Display position	Function	Status value
1	Parameter Set	A,B,C,D
222	Source of reference value	Rem (remote) Key (keyboard) Com (Serial comm.) Opt (option)
333	Source of Run/Stop command	Rem (remote) Key (keyboard) Com (Serial comm.) Opt (option)
44	Limit functions	- -No limit active VL (Voltage Limit) SL (Speed Limit) CL (Current Limit) TL (Torque Limit)

### Example: "A/Key/Rem/TL"

This means:

A: Parameter Set A is active.

Key: Reference value comes from the keyboard (CP).

Rem: Run/Stop commands come from terminals 1-22.

TL: Torque Limit active.

Description of communication format.

Integer values and bits used.

Bit	Integer representation
1 - 0	Active Parameter set, where 0=A, 1=B, 2=C, 3=D
4 - 2	Source of Reference control value, where 0=Rem, 1=Key, 2=Com, 3=Option
7 - 5	Source of Run/Stop/Reset command, where 0=Rem, 1=Key, 2=Com, 3=Option
13 - 8	Active limit functions, where 0=No limit, 1=VL, 2=SL, 3=CL, 4=TL
14	Inverter is in warning (A warning condition is active)
15	Inverter is tripped (A Trip condition is active)

Example:

Previous example "A/Key/Rem/TL"

is interpreted "0/1/0/4"

In bit format this is presented as

Bit	Interpretation	Integer representation	
0 LSB	0	A(0)	Parameter set
1	0		
2	1	Key (1)	Source of control
3	0		
4	0		
5	0	Rem (0)	Source of command
6	0		
7	0		
8	0	TL (4)	Limit functions
9	0		
10	1		
11	0		
12	0		
13	0		
14	0		
15 MSB	0	Trip condition	

In the example above it is assumed that we have no trip or warning condition (the alarm LED on the control panel is off).

## Warning [722]

Display the actual or last warning condition. A warning occurs if the AC drive is close to a trip condition but still in operation. During a warning condition the red trip LED will start to blink as long as the warning is active.

<b>722</b>	<b>0rpm</b>
<b>Warning</b>	
<b>Brake</b>	<b>17:15:38</b>
<b>Sby</b>	<b>Rem/Rem</b>

The active warning message is displayed in menu [722]. If no warning is active the message "No Error" is displayed. The following warnings are possible:

Communication integer value	Warning message**
0	No Error
1	Motor I <sup>2</sup> t
2	PTC
3	Motor lost
4	Locked rotor
5	ExtTrip1*
6	Mon MaxAlarm
7	Mon MinAlarm
8	Comm error
9	PT100
10	Crane Deviat
11	Pump
12	Ext Mot Temp
13	LC Level
14	Brake
15	Option
16	Over temp
17	Over curr F
18	Over volt D
19	Over volt G
20	Over volt
21	Over speed
22	Under voltage
23	Power fault
24	Desat
25	DLink error
26	Int error
27	Ovolt m cut
28	Over voltage
29	STO Active
30	Crane Comm
31	Encoder
32	ExtTrip2*
33	AnIn<Offset
34	ExtTrip3*
35	ExtTrip4*
36	MaxPumpClean
37	Option 2
38	SlaveCB
39	TL Trip

\* Warning messages ExtTrip1 - ExtTrip4 are configurable in menu [430].

See also Chapter 12, page 217.

\*\* This warning parameter is also represented in the standard process data message packed into a 5-bit field, see Table 64 in the Fieldbus Option manual.

If there is a need to explicitly decode a warning or trip information over bus, then menu [722] Warning with Modbus register 31016 may be mapped to any additional process value of your choice (see Fieldbus option manual Chapter 5.2.2.4).

## Digital Input Status [723]

Indicates the status of the digital inputs. See Fig. 157.

- 1 DigIn 1
- 2 DigIn 2
- 3 DigIn 3
- 4 DigIn 4
- 5 DigIn 5
- 6 DigIn 6
- 7 DigIn 7
- 8 DigIn 8

The positions one to eight (read from left to right) indicate the status of the associated input:

- 1 High
- 0 Low

The example in Fig. 157 indicates that DigIn 1, DigIn 3 and DigIn 6 are active at this moment.

<b>723</b>	<b>Orpm</b>
<b>DigIn Status</b>	<b>10100100</b>
<b>Sby</b>	<b>Rem/Rem</b>

Fig. 157 Digital input status example

## Digital Output Status [724]

Indicates the status of the digital outputs and relays. See Fig. 158.

RE indicate the status of the relays on position:

- 1 Relay1
- 2 Relay2
- 3 Relay3

DO indicate the status of the digital outputs on position:

- 1 DigOut1
- 2 DigOut2

The status of the associated output is shown.

- 1 High
- 0 Low

The example in Fig. 158 indicates that DigOut1 is active and Digital Out 2 is not active. Relay 1 is active, relay 2 and 3 are not active.

<b>724</b>	<b>Orpm</b>
<b>DigOutStatus</b>	<b>RE 100 DO 10</b>
<b>Sby</b>	<b>Rem/Rem</b>

Fig. 158 Digital output status example

## Analogue Input Status [725]

Indicates the status of the analogue inputs 1 and 2.

725		0rpm
AnIn 1	2	
0%	-2%	
Sby		Rem/Rem

Fig. 159 Analogue input status

The first row indicates the analogue inputs.

- 1 AnIn 1
- 2 AnIn 2

Reading downwards from the first row to the second row the status of the belonging input is shown in %:

- 100% AnIn1 has a negative 100% input value
- 65% AnIn2 has a 65% input value

So the example in Fig. 159 indicates that both the Analogue inputs are active.

---

**NOTE: The shown percentages are absolute values based on the full range/scale of the in- or output; so related to either 0–10 V or 0–20 mA.**

---

## Analogue Input Status [726]

Indicates the status of the analogue inputs 3 and 4.

726		0rpm
AnIn 3	4	
-100%	65%	
Sby		Rem/Rem

Fig. 160 Analogue input status

## Analogue Output Status [727]

Indicates the status of the analogue outputs. Fig. 161. E.g. if 4-20 mA output is used, the value 20% equals to 4 mA.

727		0rpm
AnOut 1	2	
-100%	65%	
Sby		Rem/Rem

Fig. 161 Analogue output status

The first row indicates the Analogue outputs.

- 1 AnOut 1
- 2 AnOut 2

Reading downwards from the first row to the second row the status of the belonging output is shown in %:

- 100%AnOut1 has a negative 100% output value
- 65%AnOut2 has a 65% output value

The example in Fig. 161 indicates that both the Analogue outputs are active.

---

**NOTE: The shown percentages are absolute values based on the full range/scale of the in- or output; so related to either 0–10 V or 0–20 mA.**

---

## I/O board Status [728] - [72A]

Indicates the status for the additional I/O on option boards 1 (B1), 2 (B2) and 3 (B3).

728		0rpm
IO Status B1		
	RE 000 DI100	
Sby		Rem/Rem

## Area D Stat [72B]

These menus are not visible in the control panel display. Only used in EmoSoftCom PC-tool (optional) and can be read via fieldbus or serial communication.

### Area D LSB [72B1]

Status bits 0 to 15.  
See Chapter 10.2.1 page 91.

### Area D MSB [72B2]

Status bits 16 and up.  
See Chapter 10.2.1 page 91.

## VIO Status [72C]

Shows the values of the 8 Virtual IO's in menu[560].

72C		0rpm
VIO Status		
	00000000	
Sby		Rem/Rem

## Run Status [72D]

This menu indicates what is blocking the drive from starting to run.

72D Run Status		
Default:		OK
OK	0	Nothing blocks the motor from starting to run.
No Run cmd	1	Missing run command.
No Enable cmd	2	Missing enable command.
Sleep	3	Blocked by sleep.
Pump Blocked	4	Blocked by pump functionality.
Trip	5	Blocked by a trip.
STO	6	Blocked by STO.
Int Blocked	7	Blocked by internal condition (setup problem e.g. failed ID-run not reset).
PEBBs nok	8	Blocked by PEBBs (all PEBBs not ready).
DC-link nok	9	Blocked by DC-link (DC-voltage not ready).
PPU load/cpy	10	Blocked by PPU load or copy.
Opt search	11	Blocked by search for options (trying to establish communication with built-in option boards).
Opt blocked	12	Blocked by option software (functionality in a non-standard software is blocking run).

**NOTE: The drive may be running even if blocked, e.g. due to commissioning or stopping.**

## 11.7.3 Stored values [730]

The shown values are the actual values built up over time. Values are stored at power down and updated again at power up.

### Run Time [731]

Displays the total time that the AC drive has been in the Run Mode.

731 Run Time	
Unit:	hh:mm:ss (hours: minutes: seconds)
Range:	00: 00: 00–262143: 59: 59

### Reset Run Time [7311]

Reset the run time counter. The stored information will be erased and a new registration period will start.

7311 Reset RunTm		
Default:		No
No	0	
Yes	1	

**NOTE: After reset the setting automatically reverts to “No”.**

### Mains time [732]

Displays the total time that the AC drive has been connected to the mains supply. This timer cannot be reset.

732 Mains Time	
Unit:	hh:mm:ss (hours: minutes: seconds)
Range:	00: 00: 00–262143: 59: 59

### Energy [733]

Displays the total energy consumption since the last energy reset [7331] took place.

733 Energy	
Unit:	Wh (shows Wh, kWh, MWh or GWh)
Range:	0.0–1GWh, Counter will restart at 0 after 1GWh

## Reset Energy [7331]

Resets the energy counter. The stored information will be erased and a new registration period will start.

7331		Rst Energy
Default:		No
No	0	
Yes	1	

**NOTE:** After reset the setting automatically goes back to "No".

## 11.8 View Trip Log [800]

Main menu with parameters for viewing all the logged trip data. In total the AC drive saves the last nine trips in the trip memory. When a trip occurs the status menus are copied to the trip message log and here are nine trip message logs [810]–[890]. The trip memory refreshes on the FIFO principle (First In, First Out). When the tenth trip occurs the oldest trip will disappear. At every trip, the actual values of several parameter are stored and available for troubleshooting.

### Trip message log with RTC [8x0]

Trip recorded with present Real Time Clock (RTC is mounted in 4-line control panel) are shown with actual time and date.

8x0		<Trip message>
Unit:		yy:mm:dd hh:mm:ss (year:month:day hours:minutes:seconds)
Range:		00: 00: 00–262143: 59: 59

### Trip Message log without RTC [8x0]

Trip recorded with no present RTC are shown with the time of the "Run Time [731]" counter at trip occurrence.

After reset of occurred trip, the trip message will disappear and menu [100] will be indicated.

8x0		<Trip message>
Unit:		hh:mm:ss (hours:minutes:seconds)
Range:		00: 00: 00–262143: 59: 59

### Trip message log [810]

When a trip occurs the menu will change to menu [810]. After resetting an alarm, the menu will change and show menu [100].

Below two examples of trip messages are shown.

Here the menu shows the date and the real time when the trip occurred.

<b>810</b>	<b>0rpm</b>
<b>Over temp</b>	
<b>2020-01-15</b>	<b>17:15:38</b>
<b>Sby</b>	<b>Rem/Rem</b>

Fig. 162

Here the menu shows the run time when the trip occurred.

<b>810</b>	<b>0rpm</b>
<b>Over temp</b>	
	<b>1396:13:00</b>
<b>Sby</b>	<b>Rem/Rem</b>

Fig. 163

Fig. 163 shows the third trip memory menu [810]: Over temperature trip occurred after 1396 hours and 13 minutes in Run time.

For Fieldbus integer value of trip message, see message table for Warning [722].

**NOTE: Bits 0–5 used for trip message value. Bits 6–15 for internal use.**

### Trip message [811]-[81Q]

The information from the status menus are copied to the trip message log when a trip occurs.

Trip menu	Copied from	Description
811	711	Process Value
812	712	Speed
813	713	Torque
814	714	Shaft Power
815	715	Electrical Power
816	716	Current
817	717	Output voltage
818	718	Frequency
819	719	DC voltage
81A	71A	IGBT Temperature
81B	71B	PT100 1, 2, 3
81C	721	VSD Status
81D	723	Digital input status
81E	724	Digital output status
81F	725	Analogue input status 1-2
81G	726	Analogue input status 3-4
81H	727	Analogue output status 1-2
81I	728	I/O status option board 1
81J	729	I/O status option board 2
81K	72A	I/O status option board 3
81L	731	Run Time
81M	732	Mains Time
81N	733	Energy

Trip menu	Copied from	Description
81O	310	Set/View ref
81P	72C	VIO Status
81Q	71C	PT100 4, 5, 6

### Trip Messages [820] - [890]

Same information as for menu [810].

All nine alarm lists contain the same type of data. For example DeviceNet parameter 31101 in alarm list 1 contains the same data information as 31151 in alarm list 2. See Menu List Chapter 15. page 251.

### Reset Trip Log [8A0]

Resets the content of the 9 trip memories.

<b>8A0 Reset Trip L</b>		
Default:		No
No	0	
Yes	1	

**NOTE: After the reset the setting goes automatically back to "NO". The message "OK" is displayed for 2 sec.**

## 11.9 System Data [900]

Main menu for viewing all the AC drive system data.

### 11.9.1 VSD Data [920]

#### VSD Type [921]

Shows the AC drive type according to the type number.

The options are indicated on the type plate of the AC drive.

**NOTE:** If the control board is not configured, then type shown is VFX48-###-##.

<b>921</b>	
<b>VFX2 . 1</b>	<b>VFX48-046-5X</b>
<b>Sby</b>	

Fig. 164 Example of AC drive type.

#### Examples

VFX48-046-5XAC drive-series

- suited for 380-480 volt mains supply, and a
- rated output current of 46 A.
- IP Class = IP54 and IP55 (2X = IP20/21)

#### Software [922]

Shows the software version number of the AC drive.

Fig. 165 gives an example of the version number.

<b>922</b>	
<b>Software</b>	<b>V 5.01 - 03.07</b>
<b>Sby</b>	

Fig. 165 Example of software version

V 5.01= Software version

- 03.07 = option version, is only visible and valid for special software, type OEM adapted software.
- 03 = (major) special software variant number
- 07= (minor) revision of this special software

Table 42 Information for Modbus and Profibus number, software version

Bit	Example	Description
7-0	32	Minor version
13-8	5	Major version
15-14		release 00: V, release version 01: P, pre-release version 10: $\beta$ , Beta version 11: $\alpha$ , Alpha version

Table 43 Information for Modbus and Profibus number, option version

Bit	Example	Description
7-0	07	Minor option version
15-8	03	Major option version

**NOTE:** It is important that the software version displayed in menu [922] is the same software version number as the software version number written on the title page of this instruction manual. If not, the functionality as described in this manual may differ from the functionality of the AC drive.

#### Build Information [9221]

Software version created, date and time.

<b>9221</b>	
<b>Build Info</b>	<b>200616145041</b>
<b>Sby</b>	
Default:	YYMMDDHHMMSS (YY=year, MM=month, DD=day, HH=hours, MM=minutes, SS=seconds)

#### Build ID [9222]

Software identification code.

<b>9222</b>	
<b>Build ID</b>	<b>BEE5529E</b>
<b>Sby</b>	

## EmoLib ID [9223]

Software library identification code.

<b>9223</b>
<b>EmoLib ID</b>
<b>9A12D134</b>
<b>Sby</b>

## Software configuration [9224]

Non-standard features are activated if the value is different from zero.

<b>9224</b>	
<b>SW Config</b>	
<b>0</b>	
<b>Sby</b>	
Default	0

## Unit name [923]

Option to enter a name of the unit for service use or customer identity. The function enables the user to define a name with max 12 characters. Use the Prev and Next key to move the cursor to the required position. Then use the + and - keys to scroll in the character list. Confirm the character by moving the cursor to the next position by pressing the Next key. See Section User-defined Unit [323].

### Example

Create user name USER 15.

1. When in the menu [923] press Next to move the cursor to the right most position.
2. Press the + key until the character U is displayed.
3. Press Next.
4. Then press the + key until S is displayed and confirm with Next.
5. Repeat until you have entered USER15.

<b>923</b>	
<b>Unit Name</b>	
<b>Sby</b>	
Default:	0

When sending a unit name you send one character at a time starting at the right most position.

## Hardware [924]

### CB Key [9241]

Unique identifier of control board; 32 bit hex value.

<b>9241</b>	
<b>CB Key</b>	
<b>00DBDA8B</b>	
<b>Sby</b>	
Example:	00DBDA8B

### CtrlPanel [925]

This menu and sub menus will be hidden if an older control panel is connected.

### Control panel software version [9251]

Shows the software version number of the control panel.

Fig. 165 gives an example of the version number.

<b>9251</b>
<b>CP SW ver</b>
<b>V 2.00</b>
<b>Sby</b>

Fig. 166 Example of software version

V 2.00 = Software version

### CP HW ver [9252]

Hardware version of connected control panel.

<b>9252</b>
<b>CP HW ver</b>
<b>11</b>
<b>Sby</b>

### CP Build ID [9253]

32 bit hex value of build ID for control panel.

Fig. 167 gives an example of the version number.

<b>9253</b>
<b>CP Build ID</b>
<b>64A26CE5</b>
<b>Sby</b>

Fig. 167 Example of control panel build ID.

## 11.9.2 Real Time clock

In the 4-line Control panel there is a built-in Real time clock. This means that actual date and time will be shown at e.g. a trip condition. There is a built-in capacitor to be able to keep the clock running if the power disappear.

In case of loss of power, the backup time for the Real time clock function is at least 60 days.

Actual date and time will be set from factory. However as the backup time is only around 60 days, it is recommended to set the Date and time during commissioning. Date and time is shown and can be set in following menus.

### Clock [930]

This menu group displays actual time and date, read only. Time and date are factory set to CET (Central European mean time). Adjust if required in following sub-menus.

<b>930</b>	<b>1240rpm</b>
<b>Clock</b>	
<b>2021-01-01</b>	<b>12:34:40</b>
<b>Run</b>	<b>Key/Key</b>

### Time [931]

Actual time, displayed as HH:MM:SS. Adjustable setting.

<b>931</b>	<b>Time</b>
Default:	00:00:00 (hh:mm:ss)

### Date [932]

Actual date, displayed as YYYY-MM-DD. Adjustable setting.

<b>932</b>	<b>Date</b>
Default:	2000-00-00 (yy-mm-dd)

### Weekday [933]

Display of actual weekday, read only.

<b>933</b>	<b>Weekday</b>
Default:	Monday
Monday	0
Tuesday	1
Wednesday	2
Thursday	3
Friday	4
Saturday	5
Sunday	6

## 11.9.3 Inspection [940]

Menu group of inspection interval feature.

### Interval [941]

Service interval of drive (runtime in hours). After passing this interval, a warning message will flash on PPU. Its unit is hours and default value is 35 000 hours = 4 years. Its maximum value is 87 600 hours, which corresponds to 10 years.

<b>941</b>	<b>Interval</b>
Default:	35 000 h
Selection:	Off, 1...87 600 h (Off=0)

### Act.Counter [942]

This menu shows hours since last inspection. The menu is read only. When the Act.Counter reach the interval set in menu [941] Interval, a warning message "Inspection!" will blink in the PPU display text area F and warning led will blink. The warning message can be reset by menu [943] or by increasing the inspection interval in menu [941].

<b>942</b>	<b>Act. Counter</b>
Default:	0 h
Range:	0... 2 000 000 000 h

### Clear Cnt [943]

In this menu hours since last inspection (shown in menu [942] Act.Counter) can be reset. After resetting the value, it will revert to "No".

<b>943</b>	<b>Clear Cnt</b>
Default:	No
No	0
Yes	1

## 11.9.4 Service cont [950]

This is a menu group for adding service contact information in the drive. It is accessible in normal login i.e. to all users. Editing of the texts is done according to the same principles as described for menu Unit name [923].

### Company Name [951]

The menu enables to define a company name with maximum16 character alphanumeric entry.

<b>951</b>	<b>Company Name</b>
Default:	Blank

### Phone Number [952]

The menu enables to define a service center contact number with maximum10 digit numeric entry.

<b>952</b>	<b>Phone Number</b>
Default:	Blank

### Address Line 1 [953]

The menu enables to define a first line of a service center address with maximum16 character alphanumeric entry.

<b>953</b>	<b>AddressLine1</b>
Default:	Blank

### Address Line 2 [954]

The menu enables to define a second line of a service center address with maximum16 character alphanumeric entry.

<b>954</b>	<b>AddressLine2</b>
Default:	Blank

### Address Line 3 [955]

The menu enables to define a third line of a service center address with maximum16 character alphanumeric entry.

<b>955</b>	<b>AddressLine3</b>
Default:	Blank

### Email Name [956]

The menu enables to define an email name of a service center with maximum16 character alphanumeric entry.

<b>956</b>	<b>Email Name</b>
Default:	Blank

### Email Domain [957]

This menu enables to define domain name of a service center with maximum16 character alphanumeric entry. The “@” symbol is fixed at the 16th position.

<b>957</b>	<b>Email Domain</b>
Default:	@cgglobal.com



## 12. Troubleshooting, Diagnoses and Maintenance

### 12.1 Trips, warnings and limits

In order to protect the AC drive the principal operating variables are continuously monitored by the system. If one of these variables exceeds the safety limit an error/warning message is displayed. In order to avoid any possibly dangerous situations, the inverter sets itself into a stop Mode called Trip and the cause of the trip is shown in the display.

Trips will always stop the AC drive. Trips can be divided into normal and soft trips, depending on the setup Trip Type, see menu “[250] Autoreset”. Normal trips are default. For normal trips the AC drive stops immediately, i.e. the motor coasts naturally to a standstill. For soft trips the AC drive stops by ramping down the speed, i.e. the motor decelerates to a standstill.

#### “Normal Trip”

- The AC drive stops immediately, the motor coasts to a standstill.
- The Trip relay or output is active (if selected).
- The Trip LED is on.
- The accompanying trip message is displayed.
- The “TRP” status indication is displayed (area D of the display).
- After reset command, the trip message will disappear and menu [100] will be indicated.

#### “Soft Trip”

- the AC drive stops by decelerating to a standstill.

During the deceleration.

- The accompanying trip message is displayed, including an additional soft trip indicator “S” before the trip time.
- The Trip LED is flashing.
- The Warning relay or output is active (if selected).

After standstill is reached.

- The Trip LED is on.
- The Trip relay or output is active (if selected).
- The “TRP” status indication is displayed (area D of the display).
- After reset command, the trip message will disappear and menu [100] will be indicated.

Apart from the TRIP indicators there are two more indicators to show that the inverter is in an “abnormal” situation.

#### “Warning”

- The inverter is close to a trip limit.
- The Warning relay or output is active (if selected).
- The Trip LED is flashing.
- The accompanying warning message is displayed in window “[722] Warning”.
- One of the warning indications is displayed (area F of the display).

#### “Limits”

- The inverter is limiting torque and/or frequency to avoid a trip.
- The Limit relay or output is active (if selected).
- The Trip LED is flashing.
- One of the Limit status indications is displayed (area D of the display).

Table 44 List of trips and warnings

Trip/Warning messages	Selections	Trip (Normal/Soft)	Warning indicators (Area D)
Motor I <sup>2</sup> t	Trip/Off/Limit	Normal/Soft	I <sup>2</sup> t
PTC	Trip/Off	Normal/Soft	
Motor PTC	On	Normal	
PT100	Trip/Off	Normal/Soft	
Motor lost	Trip/Off	Normal	
Locked rotor	Trip/Off	Normal	
ExtTrip1	Via DigIn	Normal/Soft	
Ext Mot Temp	Via DigIn	Normal/Soft	
Mon MaxAlarm	Trip/Off/Warn	Normal/Soft	
Mon MinAlarm	Trip/Off/Warn	Normal/Soft	
Comm error	Trip/Off/Warn/Change PSet	Normal/Soft	
CRIO Dev	Via Option	Normal	
CRIO Comm	Via Option	Normal	
Encoder	Trip/Off	Normal	
Pump	Via Option	Normal	
Over temp	On	Normal	OT
Over curr F	On	Normal	
Over volt D	On	Normal	
Over volt G	On	Normal	
Over volt	On	Normal	
Over speed	On	Normal	
Under voltage	On	Normal	LV
LC Level	Trip/Off/Warn Via DigIn	Normal/Soft	LCL
Desat ### *	On	Normal	
DClink error	On	Normal	
Power Fault PF ##### *	On	Normal	
Ovolt m cut	On	Normal	
Over voltage	Warning		VL
STO Active	Warning		STO
Brake	Trip/Off/Warn	Normal	
OPTION	On	Normal	
Internal error		Normal	
ExtTrip2	Via DigIn	Normal/Soft	
AnIn<Offset	Off/Trip/Warn	Normal/Soft	
ExtTrip3	Via DigIn	Normal/Soft	
ExtTrip4	Via DigIn	Normal/Soft	
MaxPumpClean	Trip/Off	Normal	
TL Trip	On/Off	Normal/Soft	

\*) Refer to table Table 45 regarding which Desat or Power Fault is triggered.

## 12.2 Trip conditions, causes and remedial action

The table later on in this section must be seen as a basic aid to find the cause of a system failure and to how to solve any problems that arise. An AC drive is mostly just a small part of a complete AC drive system. Sometimes it is difficult to determine the cause of the failure, although the AC drive gives a certain trip message it is not always easy to find the right cause of the failure. Good knowledge of the complete drive system is therefore necessary. Contact your supplier if you have any questions.

The AC drive is designed in such a way that it tries to avoid trips by limiting torque, overvolt etc.

Failures occurring during commissioning or shortly after commissioning are most likely to be caused by incorrect settings or even bad connections.

Failures or problems occurring after a reasonable period of failure-free operation can be caused by changes in the system or in its environment (e.g. wear).

Failures that occur regularly for no obvious reasons are generally caused by Electro Magnetic Interference. Be sure that the installation fulfils the demands for installation stipulated in the EMC directives. See Chapter 8. page 83.

Sometimes the so-called "Trial and error" method is a quicker way to determine the cause of the failure. This can be done at any level, from changing settings and functions to disconnecting single control cables or replacing entire drives.

The Trip Log can be useful for determining whether certain trips occur at certain moments. The Trip Log also records the time of the trip in relation to the run time counter.



**WARNING!**  
If it is necessary to open the AC drive or any part of the system (motor cable housing, conduits, electrical panels, cabinets, etc.) to inspect or take measurements as suggested in this instruction manual, it is absolutely necessary to read and follow the safety instructions in the manual.

## 12.2.1 Technically qualified personnel

Installation, commissioning, demounting, making measurements, etc., of or at the AC drive may only be carried out by personnel technically qualified for the task.

## 12.2.2 Opening the AC drive



**WARNING!**

Always switch the mains voltage off if it is necessary to open the AC drive and wait at least 7 minutes to allow the capacitors to discharge.

---



**WARNING!**

In case of malfunctioning always check the DC-link voltage, or wait one hour after the mains voltage has been switched off, before dismantling the AC drive for repair.

---

The connections for the control signals and the switches are isolated from the mains voltage. Always take adequate precautions before opening the AC drive.

## 12.2.3 Precautions to take with a connected motor

If work must be carried out on a connected motor or on the driven machine, the mains voltage must always first be disconnected from the AC drive. Wait at least 7 minutes before continuing.

## 12.2.4 Autoreset Trip

If the maximum number of Trips during Autoreset has been reached, the trip message hour counter is marked with an "A".

810	0rpm
Ext trip	
A2020-05-05	14:25:02
Sby <b>A</b>	Rem/Rem

*Fig. 168 Autoreset trip*

Fig. 168 shows the 3rd trip memory menu [830]:  
Overvoltage G trip after the maximum Autoreset attempts took place after 345 hours, 45 minutes and 12 seconds of run time.

Table 45 Trip condition, their possible causes and remedial action

Trip condition	Possible Cause	Remedy	Size**
Motor I <sup>2</sup> t "I <sup>2</sup> t"	I <sup>2</sup> t value is exceeded. - Overload on the motor according to the programmed I <sup>2</sup> t settings.	- Check on mechanical overload on the motor or the machinery (bearings, gearboxes, chains, belts, etc.) - Change the Motor I <sup>2</sup> t Current setting in menu group [230]	
PTC	Motor thermistor (PTC) exceeds maximum level. <b>NOTE: Only valid if option board PTC/ PT100 is used.</b>	- Check on mechanical overload on the motor or the machinery (bearings, gearboxes, chains, belts, etc.) - Check the motor cooling system. - Self-cooled motor at low speed, too high load. - Set PTC, menu [234] to OFF	
Motor PTC	Motor thermistor (PTC) exceeds maximum level. <b>NOTE: Only valid if [337] is enabled.</b>	- Check on mechanical overload on the motor or the machinery (bearings, gearboxes, chains, belts, etc.) - Check the motor cooling system. - Self-cooled motor at low speed, too high load. - Set PTC, menu [237] to OFF	002 - 105
PT100	Motor PT100 elements exceeds maximum level. <b>NOTE: Only valid if option board PTC/ PT100 is used.</b>	- Check on mechanical overload on the motor or the machinery (bearings, gearboxes, chains, belts, etc.) - Check the motor cooling system. - Self-cooled motor at low speed, too high load. - Set PT100 to OFF, menu [234]	
Motor lost	Phase loss or too great imbalance on the motor phases	- Check the motor voltage on all phases. - Check for loose or poor motor cable connections - If all connections are OK, contact your supplier - Set motor lost alarm to OFF.	
Locked rotor	Torque limit at motor standstill: - Mechanical blocking of the rotor.	- Check for mechanical problems at the motor or the machinery connected to the motor - Set locked rotor alarm to OFF.	
Ext trip 1	External input (DigIn 1-8) active: - active low function on the input. <b>NOTE: Exact trip message is dependent on [431] ExtTrip1 Text.</b>	- Check the equipment that initiates the external input - Check the programming of the digital inputs DigIn 1-8	
Ext trip 2	External input (DigIn 1-8) active: - active low function on the input. <b>NOTE: Exact trip message is dependent on [432] ExtTrip2 Text.</b>	- Check the equipment that initiates the external input - Check the programming of the digital inputs DigIn 1-8	
Ext trip 3	External input (DigIn 1-8) active: - active low function on the input. <b>NOTE: Exact trip message is dependent on [433] ExtTrip3 Text.</b>	- Check the equipment that initiates the external input - Check the programming of the digital inputs DigIn 1-8	
Ext trip 4	External input (DigIn 1-8) active: - active low function on the input. <b>NOTE: Exact trip message is dependent on [434] ExtTrip4 Text.</b>	- Check the equipment that initiates the external input - Check the programming of the digital inputs DigIn 1-8	
Ext Mot Temp	External input (DigIn 1-8) active: - active low function on the input.	- Check the equipment that initiates the external input - Check the programming of the digital inputs DigIn 1-8	

Table 45 Trip condition, their possible causes and remedial action

Trip condition	Possible Cause	Remedy	Size**
Internal error	Internal alarm	Contact service	
Mon MaxAlarm	Max alarm level (overload) has been reached.	-Check the load condition of the machine -Check the monitor setting in Section 11.4.1, page 165.	
Mon MinAlarm	Min alarm level (underload) has been reached.	-Check the load condition of the machine -Check the monitor setting in Section 11.4.1, page 165.	
Comm error	Error on serial communication (option)	- Check cables and connection of the serial communication. - Check all settings with regard to the serial communication - Restart the equipment including the AC drive	
Crane Deviat	CRANE board detecting deviation in motor operation.  <b>NOTE: Only used in Crane Control.</b>	- Check encoder signals - Check Deviation jumper on Crane option board. - Check the settings in menus [3AB] & [3AC]	
CraneComm	Lost communication with CRANE board.  <b>NOTE: Only used in Crane Control.</b>	- Check CRIO board - Check CRIO cable and signals.	
Encoder	Lost encoder board, encoder cable or encoder pulses. Motor speed deviation in between reference and measured speed detected.  <b>NOTE: Only valid if option board Encoder is used.</b>	- Check encoder board. - Check encoder cable and signals. - Check motor operation. - Check speed deviation settings [22G#]. - Check speed PI controller settings [37#]. - Check torque limit setting [351] - Disable encoder, set menu [22B] to OFF.	
Pump	No master pump can be selected due to error in feedback signalling.  <b>NOTE: Only used in Pump Control.</b>	- Check cables and wiring for Pump feedback signals - Check settings with regard to the pump feedback digital inputs	
Over temp	Heatsink temperature too high: - Too high ambient temperature of the AC drive - Insufficient cooling - Too high current - Blocked or stuffed fans	- Check the cooling of the AC drive cabinet. - Check the functionality of the built-in fans. The fans must switch on automatically if the heatsink temperature gets too high. At power up the fans are briefly switched on. - Check AC drive and motor rating - Clean fans - Check / reduce switching frequency settings in [22A] / [22E1].	
Over curr F	Motor current exceeds the peak AC drive current: - Too short acceleration time. - Too high motor load - Excessive load change - Soft short-circuit between phases or phase to earth - Poor or loose motor cable connections - Too high IxR Compensation level	- Check the acceleration time settings and make them longer if necessary. - Check the motor load. - Check on bad motor cable connections - Check on bad earth cable connection - Check on water or moisture in the motor housing and cable connections. - Lower the level of IxR Compensation [352]	
Over volt D(eceleration)	Too high DC Link voltage: - Too short deceleration time with respect to motor/machine inertia.	- Check the deceleration time settings and make them longer if necessary.	
Over volt G(eneration)	- Too small brake resistor malfunctioning Brake chopper	- Check the dimensions of the brake resistor and the functionality of the Brake chopper (if used)	
Over volt (Mains)	Too high DC Link voltage, due to too high mains voltage	- Check the main supply voltage	
O(ver) volt M(ains) cut		- Try to take away the interference cause or use other main supply lines.	

Table 45 Trip condition, their possible causes and remedial action

Trip condition	Possible Cause	Remedy	Size**
Over speed	Motor speed measurement exceeds maximum level. 110% of max speed (all parameter sets).	<ul style="list-style-type: none"> <li>- Check encoder cables, wiring and setup</li> <li>- Check motor data setup [22x]</li> <li>- Perform short ID-run</li> </ul>	
Under voltage	Too low DC Link voltage: <ul style="list-style-type: none"> <li>- Too low or no supply voltage</li> <li>- Mains voltage dip due to starting other major power consuming machines on the same line.</li> </ul>	<ul style="list-style-type: none"> <li>- Make sure all three phases are properly connected and that the terminal screws are tightened.</li> <li>- Check that the mains supply voltage is within the limits of the AC drive.</li> <li>- Try to use other mains supply lines if dip is caused by other machinery</li> <li>- Use the function low voltage override [421]</li> </ul>	
LC Level	Low liquid cooling level in external reservoir. External input (DigIn 1-8) active: <ul style="list-style-type: none"> <li>- active low function on the input.</li> </ul> NOTE: Only valid for AC drive types with Liquid Cooling option.	<ul style="list-style-type: none"> <li>- Check liquid cooling</li> <li>- Check the equipment and wiring that initiates the external input</li> <li>- Check the programming of the digital inputs DigIn 1-8</li> </ul>	
OPTION	If an Option specific trip occurs	Check the description of the specific option	
Desat	Failure in output stage, <ul style="list-style-type: none"> <li>- desaturation of IGBTs</li> <li>- Hard short circuit between phases or phase to earth</li> <li>- Earth fault</li> <li>- For size B - D also the Brake IGBT</li> </ul>	<ul style="list-style-type: none"> <li>- Check on bad motor cable connections</li> <li>- Check on bad earth cable connections</li> <li>- Check on water and moisture in the motor housing and cable connections</li> <li>- Check that the rating plate data of the motor is correctly entered.</li> <li>- Check the brake resistor, brake IGBT and wiring.</li> <li>- For size H and up, check the cables from the PEBBs to the motor, that all are in correct order in parallel connection</li> </ul>	002 -105
Desat U+ *			090 & Up
Desat U- *			
Desat V+ *			
Desat V- *			
Desat W+ *			
Desat W- *			
Desat BCC *			
DC link error	DC link voltage ripple exceeds maximum level	<ul style="list-style-type: none"> <li>- Make sure all three phases are properly connected and that the terminal screws are tightened.</li> <li>- Check that the mains supply voltage is within the limits of the AC drive.</li> <li>- Try to use other mains supply lines if dip is caused by other machinery.</li> </ul>	
Power Fault	One of the PF (Power Fault) trips below has occurred, but could not be determined.	<ul style="list-style-type: none"> <li>- Check the PF errors and try to determine the cause. The trip history can be helpful.</li> </ul>	
PF Fan Err *	Error in fan module	<ul style="list-style-type: none"> <li>- Check for clogged air inlet filters in panel door and blocking material in fan module.</li> </ul>	090 & Up
PF HCB Err*	Error in controlled rectifier module (HCB)	<ul style="list-style-type: none"> <li>- Check mains supply voltage</li> </ul>	060 & Up
PF Curr Err	Error in current balancing: <ul style="list-style-type: none"> <li>- between different modules.</li> <li>- between two phases within one module.</li> </ul>	<ul style="list-style-type: none"> <li>- Check motor.</li> <li>- Check fuses and line connections</li> <li>- Check the individual motor current leads with an clamp on amp meter.</li> </ul>	430 & Up
PF Overvolt	Error in voltage balancing, overvoltage detected in one of the power modules (PEBB)	<ul style="list-style-type: none"> <li>- Check motor.</li> <li>- Check fuses and line connections.</li> </ul>	430 & Up
PF Comm Err *	Internal communication error	Contact service	
PF Int Temp *	Internal temperature too high	Check internal fans	
PF Temp Err *	Malfunction in temperature sensor	Contact service	
PF DC Err *	DC-link error and mains supply fault	<ul style="list-style-type: none"> <li>- Check mains supply voltage</li> <li>- Check fuses and line connections.</li> </ul>	060 & Up
PF Sup Err *	Mains supply fault	<ul style="list-style-type: none"> <li>- Check mains supply voltage</li> <li>- Check fuses and line connections.</li> </ul>	
PF PBuC*	Powerboard micro controller reset by watchdog.		

Table 45 Trip condition, their possible causes and remedial action

Trip condition	Possible Cause	Remedy	Size**
Brake	Brake tripped on brake fault (not released) or Brake not engaged during stop.	<ul style="list-style-type: none"> <li>- Check Brake acknowledge signal wiring to selected digital input.</li> <li>- Check programming of digital input DigIn 1-8, [520].</li> <li>- Check circuit breaker feeding mechanical brake circuit.</li> <li>- Check mechanical brake if acknowledge signal is wired from brake limit switch.</li> <li>- Check brake contactor.</li> <li>- Check settings [33C], [33D], [33E], [33F].</li> </ul>	
AnIn<Offset	An analogue input signal is below 75% of the configured minimum value.	<ul style="list-style-type: none"> <li>- Check cables and connections of the analogue inputs.</li> <li>- Check the configured minimum values for the analogue inputs.</li> <li>- Disable AnIn Fault in menu [51D].</li> </ul>	
MaxPumpClean	Too many cleaning attempts. Pump not cleaned.	Change settings in menu [392E]. Manual cleaning of pump.	
TL Trip	Torque limited for too long. Both user configurable limitations and protective functions can limit the torque.	Change settings in menu [357]. Check warnings and indications before a trip to determine what causes the torque limitation. It can be a user setting such as [351] and [355] or a protective function.	

\* = 2...15 Module number if parallel power units (size 430–3000 A)

\*\* = If no size is mentioned in this column, the information is valid for all sizes.

## 12.3 Maintenance

The AC drive is designed to require minimum of servicing and maintenance. There are however some things which must be inspected regularly in order to optimise product life time.

- Keep the AC drive unit clean and cooling efficient (clean air inlets, heatsink profile, parts, components, etc)
- There is an internal fan that should be inspected and cleaned from dust if necessary.
- If AC drives are built into cabinets, also check and clean the dust filters of the cabinets regularly.
- Check external wiring, connections and control signals.
- Check tightening of all terminal screws regularly, especially important are power and motor cable connections

Preventive maintenance can optimise the product life time and secure trouble free operation without interruptions.

For more information on maintenance, please contact your CG Drives & Automation service partner.

### Precautions to take with a connected motor

---

**NOTE: Refer to motor manufacturers instruction manual for motor maintenance requirements.**

---

If work must be carried out on a connected motor or on the driven machine, the mains voltage must always first be disconnected from the drive unit.

If your drive is connected to a PMSM (Permanent magnet motor) it is most important that you also disconnect the motor before performing any maintenance on the drive unit.



**WARNING!**

**Do not work on a drive when a rotating PMSM- permanent magnet motor is connected to it.**

**A rotating PMSM motor energizes the drive including its power terminals.**

---

## 13. Options

The standard options available are described here briefly. Some of the options have their own instruction or installation manual. For more information please contact your supplier. See also in “Technical catalogue AC drives” for more info.

### 13.1 Control panel

Control panel with a 4-line display.

Part number		Description
IP54	IP20/21	
01-6520-00	01-6521-00	4-line Control panel (standard)
01-6520-11	01-6521-11	4-line Control panel with Bluetooth (optional)
01-6520-20	01-6521-20	4-line Control panel with WiFi (optional)

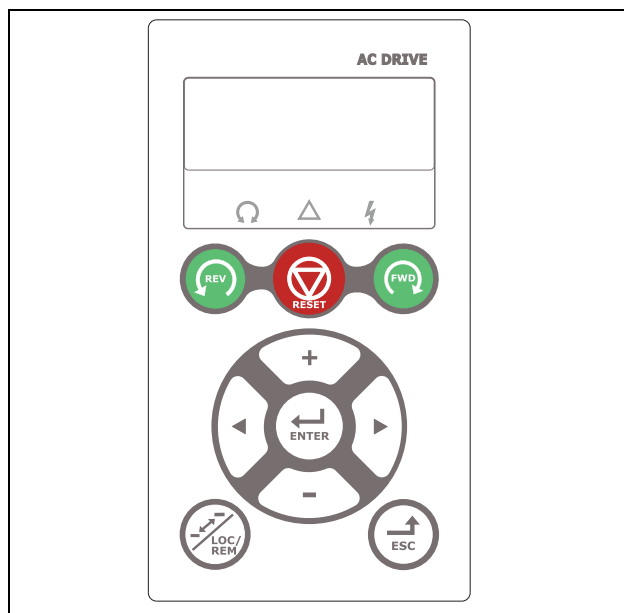

Fig. 169 Control panel with 4-line display.

The display is back lit and consists of 4 rows, each with space for 20 characters. The Control panel is equipped with real time clock function. This means that actual date and time will be shown at e.g. a trip condition. There is also an optional Control panel with Bluetooth communication available for connection with cellphone or tablet.

### 13.2 External control panel kits

#### 13.2.1 Control panel kit, including blank panel

Part number	Description
01-6878-40	Control panel kit (size B)
01-6879-40	Control panel kit (size C)
01-6880-40	Control panel kit (size D and up)



Fig. 170 Control panel kit, including blank panel.

External control panel IP54 suitable for mounting on a cabinet door. This option is to be used in combination with an AC drive module ordered with a built-in control panel.

#### 13.2.2 Control panel kit, including control panel

Part number	Description
01-6878-00	Standard Control panel (size B)
01-6878-10	Control panel with Bluetooth (size B)
01-6878-20	Control panel with WiFi (size B)
01-6879-00	Standard Control panel (size C)
01-6879-10	Control panel with Bluetooth (size C)
01-6879-20	Control panel with WiFi (size C)
01-6880-00	Standard Control panel (size D and up)
01-6880-10	Control panel with Bluetooth (size D and up)
01-6880-20	Control panel with WiFi (size D and up)



Fig. 171 Control panel kit, including control panel.

External control panel IP54 suitable for mounting on a panel door. This option is to be used in combination with an AC drive module ordered with a blank control panel.

### 13.3 Handheld Control Panel 2.0

Part number	Description
01-5039-30	Handheld Control Panel 2.0 complete for FDU/VFX2.0/2.1 or CDU/CDX 2.0/2.1 including 4-line control panel



Fig. 172 Handheld Control Panel 2.0 (4-line Control Panel).

The Handheld Control Panel - HCP 2.0 is a complete control panel, easy to connect to the AC drive, for temporary use when e.g. commissioning, servicing and so on.

The HCP has full functionality including memory. It is possible to set parameters, view signals, actual values, fault logger information and so on. It is also possible to use the memory to copy all data (such as parameter set data and motor data) from one AC drive to the HCP and then load this data to other AC drives.

### 13.4 Gland kits

Gland kits are available for frame sizes B, C and D.

Optional gland kits are available for IP54 frame sizes B, C, D, C69 and D69.

Metal EMC glands are used for motor and brake resistor cables.

Part Number	Current (dimension)	Frame size
01-4601-21	3 - 6 A (M16 - M20)	B
01-4601-22	8 - 10 A (M16 - M25)	
01-4601-23	13 - 18 A (M16 - M32)	
01-4399-01	26 - 31 A (M12 - M32)	C
01-4399-00	37 - 46 A (M12 - M40)	
01-4833-00	61 - 74 A (M20 - M50)	D
01-7248-00	2 - 10 A (M20 - M25)	C69
01-7248-10	13 - 25 A (M20 - M32)	C69
01-7247-00	33 - 58 A (M20 - M40)	D69

### 13.5 EmoSoftCom

EmoSoftCom is an optional software that runs on a personal computer. It can also be used to load parameter settings from the AC drive to the PC for backup and printing. Recording can be made in oscilloscope mode. Please contact CG Drives & Automation sales for further information.

### 13.6 EmoDrive App

The EmoDrive App can be used with mobile devices such as smartphones and tablets. It is a versatile commissioning and maintenance online and offline tool including all main functions as included in the EmoSoftCom PC-tool. E.g. parameter settings save and restore, signal and fault logger monitoring, oscilloscope function and commissioning report, but also for day-by-day status check of your application.

File formats are identical to EmoSoftCom, allowing files to be used in both tools.

The EmoDrive App has support for both Bluetooth (BLE) and WiFi type of communications. Communication port in FDU/VFX 2.1 drive is available via an optional type (BLE/WiFi) of drive control panel (PPU).

The EmoDrive App works with both IOS systems (iPhone/iPad, App Store) as well as Android system phones and tablets (Play Store).

## 13.7 Brake chopper

All AC drives can be fitted with an optional built-in brake chopper. The brake resistor must be mounted outside the AC drive. The choice of the resistor depends on the application switch-on duration and duty-cycle. This option can not be after mounted.



### WARNING!

The table gives the minimum values of the brake resistors. Do not use resistors lower than this value. The AC drive can trip or even be damaged due to high braking

currents.

The following formula can be used to define the power of the connected brake resistor:

$$P_{\text{resistor}} = \frac{(\text{Brake level } V_{\text{DC}})^2}{R_{\text{min}}} \times \text{ED}$$

Where:

- $P_{\text{resistor}}$  required power of brake resistor
- Brake level  $V_{\text{DC}}$  brake voltage level (see Table 46)
- $R_{\text{min}}$  minimum allowable brake resistor (see Table 47, Table 48 and Table 49)
- ED effective braking period. Defined as:

$$\text{ED} = \frac{t_{\text{br}}}{120 \text{ [s]}}$$

- $t_{\text{br}}$  Active braking time at nominal braking power during a 2 minute operation cycle.

Maximum value of ED = 1, meaning continuous braking.

Table 46

Supply voltage ( $V_{\text{AC}}$ ) (set in menu [21B])	Brake level ( $V_{\text{DC}}$ )
220–240	380
380–415	660
440–480	780
500–525	860
550–600	1000
660–690	1150

Table 47 Brake resistor VFX48 V types

Type	$R_{\text{min}}$ [ohm] if supply 380–415 $V_{\text{AC}}$	$R_{\text{min}}$ [ohm] if supply 440–480 $V_{\text{AC}}$
VFX48-003	43	50
-004	43	50
-006	43	50
-008	43	50
-010	43	50
-013	43	50
-018	43	50
-025	26	30
-026	26	30
-030	26	30
-031	26	30
-036	17	20
-037	17	20
-045	17	20
-046	17	20
-058	15.5	19
-060	10	12
-061	10	12
-072	10	12
-074	10	12
-088	7.5	9
-090	3.8	4.4
-105	6.5	8
-106	3.8	4.4
-109	3.8	4.4
-142	3.8	4.4
-146	3.8	4.4
-171	3.8	4.4
-175	3.8	4.4
-205	2.7	3.1
-210	2.7	3.1
-244	2.7	3.1
-250	2.7	3.1
-293	2.3	2.8
-295	2.3	2.8
-365	1.8	2.2
-430	2 x 2.7	2 x 3.1
-500	2 x 2.7	2 x 3.1
-590	2 x 2.3	2 x 2.8
-660	2 x 1.8	2 x 2.2
-730	2 x 1.8	2 x 2.2
-810	3 x 2.3	3 x 2.8
-885	3 x 2.3	3 x 2.8
-1010	3 x 1.8	3 x 2.2
-1100	3 x 1.8	3 x 2.2
-1300	4 x 1.8	4 x 2.2
-1460	4 x 1.8	4 x 2.2
-1710	5 x 1.8	5 x 2.2
-1820	5 x 1.8	5 x 2.2
-2190	6 x 1.8	6 x 2.2
-2550	7 x 1.8	7 x 2.2
-2920	8 x 1.8	8 x 2.2

Table 48 Brake resistor VFX52 V types

Type	Rmin [ohm] if supply 440–480 V <sub>AC</sub>	Rmin [ohm] if supply 500–525 V <sub>AC</sub>
VFX52-003	50	55
-004	50	55
-006	50	55
-008	50	55
-010	50	55
-013	50	55
-018	50	55
-026	30	32
-031	30	32
-037	20	22
-046	20	22
-061	12	14
-074	12	14

Table 49 Brake resistor VFX69 V types

Type	Rmin [ohm] if supply 500–525 V <sub>AC</sub>	Rmin [ohm] if supply 550–600 V <sub>AC</sub>	Rmin [ohm] if supply 660–690 V <sub>AC</sub>
VFX69-002	30.4	34.8	40.0
-003	30.4	34.8	40.0
-004	30.4	34.8	40.0
-005	30.4	34.8	40.0
-008	30.4	34.8	40.0
-010	30.4	34.8	40.0
-013	30.4	34.8	40.0
-018	30.4	34.8	40.0
-021	30.4	34.8	40.0
-025	30.4	34.8	40.0
-033	12.9	14.8	17.0
-042	12.9	14.8	17.0
-050	12.9	14.8	17.0
-058	12.9	14.8	17.0
-082	4.9	5.7	6.5
-090	4.9	5.7	6.5
-109	4.9	5.7	6.5
-146	4.9	5.7	6.5
-175	4.9	5.7	6.5
-200	4.9	5.7	6.5
-250	2 x 4.9	2 x 5.7	2 x 6.5
-300	2 x 4.9	2 x 5.7	2 x 6.5
-375	2 x 4.9	2 x 5.7	2 x 6.5
-400	2 x 4.9	2 x 5.7	2 x 6.5
-430	3 x 4.9	3 x 5.7	3 x 6.5
-500	3 x 4.9	3 x 5.7	3 x 6.5
-595	3 x 4.9	3 x 5.7	3 x 6.5
-650	4 x 4.9	4 x 5.7	4 x 6.5
-720	4 x 4.9	4 x 5.7	4 x 6.5
-800	4 x 4.9	4 x 5.7	4 x 6.5
-905	5 x 4.9	5 x 5.7	5 x 6.5
-995	5 x 4.9	5 x 5.7	5 x 6.5

Table 49 Brake resistor VFX69 V types

-1K2	6 x 4.9	6 x 5.7	6 x 6.5
-1K4	7 x 4.9	7 x 5.7	7 x 6.5
-1K6	8 x 4.9	8 x 5.7	8 x 6.5
-1K8	9 x 4.9	9 x 5.7	9 x 6.5
-2K0	10 x 4.9	10 x 5.7	10 x 6.5
-2K2	11 x 4.9	11 x 5.7	11 x 6.5
-2K4	12 x 4.9	12 x 5.7	12 x 6.5
-2K6	13 x 4.9	13 x 5.7	13 x 6.5
-2K8	14 x 4.9	14 x 5.7	14 x 6.5
-3K0	15 x 4.9	15 x 5.7	15 x 6.5

**NOTE:** Although the AC drive will detect a failure in the brake electronics, the use of resistors with a thermal overload which will cut off the power at overload is strongly recommended.

The brake chopper option is built-in by the manufacturer and must be specified when the AC drive is ordered.

## 13.8 I/O Board

Part number	Description
01-3876-01	I/O option board 2.0

Each I/O option board 2.0 provides three extra relay outputs and three extra isolated digital inputs (24V). The I/O Board works in combination with the Pump/Fan Control, but can also be used as a separate option. Maximum 3 I/O boards possible. This option is described in a separate manual.

## 13.9 Encoder

Part number	Description
01-3876-03	Encoder 2.0 option board

The Encoder 2.0 option board, used for connection of feedback signal of the actual motor speed via an incremental encoder is described in a separate manual.

For Emotron FDU and for VFX in V/Hz mode this function is for speed read-out only or for spin start function. No speed control.

## 13.10 PTC/PT100

Part number	Description
01-3876-08	PTC/PT100 2.0 option board

The PTC/PT100 2.0 option board for connecting motor thermistors and max 3 PT100 elements to the AC drive is described in a separate manual.

## 13.11 Crane option board

Part number	Description
590059	Crane interface board, 230 V <sub>AC</sub>
590060	Crane interface board, 24 V <sub>DC</sub>

This option is used in crane applications. The crane option board 2.0 is described in a separate manual.

## 13.12 Communication options

Part number	Description	From VFX software version (see menu [922])
01-3876-05	Profibus DP	4.0
01-3876-06	DeviceNet	4.0
01-3876-09	Modbus/TCP, Industrial Ethernet	4.11
01-3876-10	EtherCAT, Industrial Ethernet	4.32
01-3876-11	Profinet IO, one port Industrial Ethernet	4.32
01-3876-12	Profinet IO, two port Industrial Ethernet	4.32
01-3876-13	EtherNet/IP, two port Industrial Ethernet	4.36
01-3876-16	CANopen	4.42
01-3876-17	Modbus/TCP, two port Industrial Ethernet	5.10

For communication with the AC drive there are several option boards for communication. There are different options for Fieldbus communication and one serial communication option with RS-232 or RS-485 interface which has galvanic isolation.

## 13.13 Safe Torque Off (STO)

- The OSTO\_100 option board for safety function Safe Torque Off (STO) is an extension of the Emotron AC drive used for functional safety purposes to achieve e.g. prevention of unexpected start-up of motor (POUS) or Emergency stop. This ensures the safety of both the operator and the machinery in accordance with the Machine Directive.
- The Safe Torque Off function works according to the standards EN IEC 61800-5-2, EN IEC 61508, and EN ISO 13849-1. Safety-related parameters are specified in "Emotron OSTO\_100 option board for safety function Safe Torque Off (STO)" (01-7513-11), Chapter "Technical Data".
- For more information please consult "Emotron OSTO\_100 option board for safety function Safe Torque Off (STO)" (01-7513-11).

## 13.14 EMC filter class C1/C2

EMC filter according to EN IEC 61800-3:2018 class C1 (for frame size C types) and C2 - 1st environment restricted distribution.

For sizes B,C, C2, D and D2, the filter is mounted inside the drive module.

For sizes E and up, external EMC filters are available. For more information refer to "Technical catalogue for AC drives".

---

**NOTE: EMC filter according to class C3 - 2nd environment included as standard in all drive units.**

---

## 13.15 Output chokes

Output chokes, which are supplied separately, are recommended for lengths of screened motor cable longer than 100 m. Because of the fast switching of the motor voltage and the capacitance of the motor cable (both line to line and line to earth screen), large switching currents can be generated with long lengths of motor cable. Output chokes prevent the AC drive from tripping and should be installed as closely as possible to the AC drive.

See also in "Technical catalogue AC drives" for filter selection guide.

## 13.16 Liquid cooling

AC drive modules in frame sizes E - H8 and F69 - T69 are available in a liquid cooled version. These units are designed for connection to a liquid cooling system, normally a heat exchanger of liquid-liquid or liquid-air type. Heat exchanger is not part of the liquid cooling option.

Drive units with parallel power modules (frame size H - T69) are delivered with a dividing unit for connection of the cooling liquid. The drive units are equipped with rubber hoses with leak-proof quick couplings. The Liquid cooling option is described in a separate manual.

## 13.17 Top cover for IP20/21 version

Part number	Description
01-5356-00	Top cover for frame size C2
01-5355-00	Top cover for frame sizes D2, E2 and F2

This Top cover can be mounted on IP20 versions of frame sizes C2, D2, E2 and F2.

By mounting the top cover, the protection class will change to IP21 in accordance with EN 60529 standard.

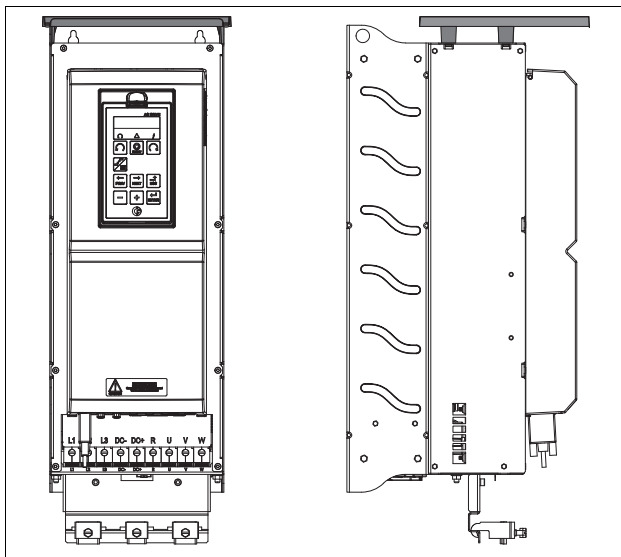

*Fig. 173 Optional top cover mounted on frame size D2.*

## 13.18 Other options

Following options are also available, for more information regarding these options, see in “Technical catalogue AC drives”.

**Overshoot clamp**

**Sine wave filter**

**Common mode filter**

**Brake resistors**

## 13.19 AFE - Active Front End

Emotron AC Drives from CG Drives & Automation are also available as Low harmonic drives and Regenerative drives. You will find more information on [www.emotron.com](http://www.emotron.com) / [www.cgglobal.com](http://www.cgglobal.com).

# 14. Technical Data

## 14.1 Electrical specifications related to model

Note: Use motor rated current for drive sizing.

### Emotron VFX 2.1 - IP20/21 version

Table 50 Typical motor power at mains voltage 230 V. AC drive main voltage range 230 - 480 V.

Model VFX	Max. output current [A]*	Normal duty (120%, 1 min every 10 min)				Heavy duty (150%, 1 min every 10 min)			Frame size
		Power @230V [kW]	Power @230V [HP]	Rated current [A]	Power Loss (kW)	Power @230V [kW]	Power @230V [HP]	Rated current [A]	
48-025-20	38	5.5	7.5	25	0.35	4	5	20	C2
48-030-20	45	7.5	10	30	0.44	5.5	7.5	24	
48-036-20	54	7.5	10	36	0.46	7.5	10	29	
48-045-20	68	11	15	45	0.6	7.5	10	36	
48-058-20**	68	15	20	58	0.77	11	15	46	
48-060-20	90	15	20	60	0.8	11	15	48	D2
48-072-20	108	18.5	25	72	0.9	15	20	58	
48-088-20	132	22	30	88	1.2	18.5	25	70	
48-105-20**	132	30	40	105	1.3	22	30	84	
48-142-20	170	37	50	142	1.7	30	40	114	E2
48-171-20**	205	45	60	171	2.1	37	50	137	E4
48-145-20	170	37	50	145	1.7	30	40	114	
48-174-20	205	45	60	174	2.1	37	50	137	
48-205-20	246	55	75	205	2.3	45	60	164	F2
48-244-20**	293	75	100	244	3	55	75	195	
48-293-20	352	90	125	293	3.4	75	100	235	
48-365-20***	438	110	150	365	3.7	90	125	292	FA2

Rated data at an ambient temperature of 50 °C without deration.

\* Available during a limited time and as long as allowed by the drive temperature.

\*\* Rated data at 40 °C without deration

\*\*\* Rated data at 45 °C without deration

NOTE: The frame size E4 is only available on the Indian market and is not UL or Marine approved.

Table 51 Typical motor power at mains voltage 400 and 460 V. AC drive main voltage range 230 - 480 V.

Model VFX	Max. output current [A]*	Normal duty (120%, 1 min every 10 min)				Heavy duty (150%, 1 min every 10 min)			Frame size
		Power @400V [kW]	Power @460V [hp]	Rated current [A]	Power Loss (kW)	Power @400V [kW]	Power @460V [hp]	Rated current [A]	
48-025-20	38	11	15	25	0.39	7.5	10	20	C2
48-030-20	45	15	20	30	0.48	11	15	24	
48-036-20	54	18.5	25	36	0.51	15	20	29	
48-045-20	68	22	30	45	0.66	18.5	25	36	
48-058-20**	68	30	40	58	0.85	22	30	46	
48-060-20	90	30	40	60	0.9	22	30	48	D2
48-072-20	108	37	50	72	1.0	30	40	58	
48-088-20	132	45	60	88	1.3	37	50	70	
48-105-20**	132	55	75	105	1.4	45	60	84	E2
48-142-20	170	75	100	142	1.9	55	75	114	
48-171-20**	205	90	125	171	2.3	75	100	137	E4
48-145-20	170	75	100	145	1.9	55	75	114	
48-174-20	174	90	125	174	2.3	75	100	137	F2
48-205-20	246	110	150	205	2.6	90	125	164	
48-244-20**	293	132	200	244	3.2	110	150	195	
48-293-20	352	160	250	293	3.6	132	200	235	FA2
48-365-20***	438	200	300	365	4.1	160	250	292	

Rated data at an ambient temperature of 50 °C without deration.

\* Available during a limited time and as long as allowed by the drive temperature.

\*\* Rated data at 40 °C without deration

\*\*\* Rated data at 45 °C without deration

**NOTE: The frame size E4 is only available on the Indian market and is not UL or Marine approved.**

Table 52 Typical motor power at mains voltage 575 and 690 V. AC drive main voltage range 500 - 690 V.

Model VFX	Max. output current [A]*	Normal duty (120%, 1 min every 10 min)			Heavy duty (150%, 1 min every 10 min)			Frame size
		Power @575V [hp]	Power @690V [kW]	Rated current [A]	Power @575V [hp]	Power @690V [kW]	Rated current [A]	
69-033-20	53	30	30	33	25	22	26	D2(69)
69-042-20	67	40	37	42	30	30	34	
69-050-20	80	50	45	50	40	37	40	
69-058-20	93	60	55	58	40	45	46	

\* Available during limited time and as long as allowed by drive temperature.

## Emotron VFX 2.1 - IP54 version (Model 48-430 and up also available as IP20)

Table 53 Typical motor power at mains voltage 230 V. AC drive main voltage range 230 - 480 V.

Model VFX	Max. output current [A]*	Normal duty (120%, 1 min every 10 min)			Heavy duty (150%, 1 min every 10 min)			Frame size (Number of PEBB's)**	IP class	
		Power @230V [kW]	Power @230V [HP]	Rated current [A]	Power @230V [kW]	Power @230V [HP]	Rated current [A]			
48-003-54	3.8	0.37	0.5	2.5	0.37	0.5	2.0	B	IP 54 wall mounted	
48-004-54	6.0	0.75	1	4.0	0.55	0.75	3.2			
48-006-54	9.0	1.1	1.5	6.0	0.75	1	4.8			
48-008-54	11.3	1.5	2	7.5	1.1	1.5	6.0			
48-010-54	14.3	2.2	3	9.5	1.5	2	7.6			
48-013-54	19.5	2.2	3	13.0	2.2	3	10.4			
48-018-54	27.0	4	5	18.0	3	3	14.4			
48-026-54	39	5.5	7.5	26	4	5	21	C		
48-031-54	46	7.5	10	31	5.5	7.5	25			
48-037-54	55	7.5	10	37	7.5	10	29.6			
48-046-54	69	11	15	46	7.5	10	37			
48-061-54	92	15	20	61	11	15	49	D		
48-074-54	111	18.5	25	74	15	20	59			
48-090-54	108	22	30	90	18.5	25	72	E		
48-109-54	131	30	40	109	22	30	87			
48-146-54	175	37	50	146	30	40	117			
48-175-54	210	45	60	175	37	50	140			
48-210-54	252	55	75	210	45	60	168	F		
48-250-54	300	75	100	250	55	75	200			
48-295-54	354	90	125	295	75	100	236			
48-365-54	438	110	150	365	90	125	292	FA		
48-430-IP	516	110	150	430	110	125	344	H		IP 20 module or IP54 cabinet
48-500-IP	600	160	200	500	110	150	400	G2		
48-590-IP	708	200	250	590	132	200	472			
48-660-IP	792	200	250	660	160	200	528	H2		
48-730-IP	876	220	300	730	160	250	584			
48-810-IP	972	250	350	810	200	250	648	G3		
48-885-IP	1062	250	350	885	220	300	708			
48-1010-IP	1212	315	400	1010	250	350	808	H3		
48-1100-IP	1320	355	450	1100	250	350	880			
48-1300-IP	1560	400	550	1300	315	450	1040	H4		
48-1460-IP	1752	450	600	1460	355	500	1168			
48-1710-IP	2052	560	750	1710	450	550	1368	H5		
48-1820-IP	2184	600	800	1820	450	600	1456			
48-2190-IP	2628	710	900	2190	560	750	1752	H6		
48-2550-IP	3060	800	1100	2550	630	850	2040	H7		
48-2920-IP	3504	900	1200	2920	750	1000	2336	H8		
Larger sizes available on request										

\* Available during limited time and as long as allowed by drive temperature.

\*\* PEBB= Power Electronic Building Block (power module).

Table 54 Typical motor power at mains voltage 400 V. AC drive main voltage range 230 - 480 V.

Model VFX	Max. output current [A]*	Normal duty (120%, 1 min every 10 min)		Heavy duty (150%, 1 min every 10 min)		Frame size (Number of PEBB's)**	IP class
		Power @400V [kW]	Rated current [A]	Power @400V [kW]	Rated current [A]		
48-003-54	3.8	0.75	2.5	0.55	2.0	B	IP 54 wall mounted
48-004-54	6.0	1.5	4.0	1.1	3.2		
48-006-54	9.0	2.2	6.0	1.5	4.8		
48-008-54	11.3	3	7.5	2.2	6.0		
48-010-54	14.3	4	9.5	3	7.6		
48-013-54	19.5	5.5	13.0	4	10.4		
48-018-54	27.0	7.5	18.0	5.5	14.4		
48-026-54	39	11	26	7.5	21	C	
48-031-54	46	15	31	11	25		
48-037-54	55	18.5	37	15	29.6		
48-046-54	69	22	46	18.5	37	D	
48-061-54	92	30	61	22	49		
48-074-54	111	37	74	30	59	E	
48-090-54	108	45	90	37	72		
48-109-54	131	55	109	45	87		
48-146-54	175	75	146	55	117	F	
48-175-54	210	90	175	75	140		
48-210-54	252	110	210	90	168	FA	
48-250-54	300	132	250	110	200		
48-295-54	354	160	295	132	236	H	
48-365-54	438	200	365	160	292		
48-430-IP	516	220	430	200	344	G2	
48-500-IP	600	250	500	220	400		
48-590-IP	708	315	590	250	472	H2	
48-660-IP	792	355	660	250	528		
48-730-IP	876	400	730	315	584	G3	
48-810-IP	972	450	810	355	648		
48-885-IP	1062	500	885	400	708	H3	
48-1010-IP	1212	560	1010	450	808		
48-1100-IP	1320	630	1100	500	880	H4	
48-1300-IP	1560	710	1300	560	1040		
48-1460-IP	1752	800	1460	630	1168	H5	
48-1710-IP	2052	900	1710	750	1368		
48-1820-IP	2184	1000	1820	800	1456	H6	
48-2190-IP	2628	1200	2190	1000	1752		
48-2550-IP	3060	1400	2550	1120	2040	H7	
48-2920-IP	3504	1600	2920	1300	2336		
Larger sizes available on request							

\* Available during limited time and as long as allowed by drive temperature.

\*\* PEBB= Power Electronic Building Block (power module).

Table 55 Typical motor power at mains voltage 460 V. AC drive main voltage range 230 - 480 V.

Model VFX	Max. output current [A]*	Normal duty (120%, 1 min every 10 min)		Heavy duty (150%, 1 min every 10 min)		Frame size (Number of PEBB's)**	IP class
		Power @460V [HP]	Rated current [A]	Power @460V [HP]	Rated current [A]		
48-003-54	3.8	1	2.5	1	2.0	B	IP 54 wall mounted
48-004-54	6.0	2	4.0	1.5	3.2		
48-006-54	9.0	3	6.0	2	4.8		
48-008-54	11.3	3	7.5	3	6.0		
48-010-54	14.3	5	9.5	3	7.6		
48-013-54	19.5	7.5	13.0	5	10.4		
48-018-54	27.0	10	18.0	7.5	14.4		
48-026-54	39	15	26	10	21	C	
48-031-54	46	20	31	15	25		
48-037-54	55	25	37	20	29.6		
48-046-54	69	30	46	25	37	D	
48-061-54	92	40	61	30	49		
48-074-54	111	50	74	40	59	E	
48-090-54	108	60	90	50	72		
48-109-54	131	75	109	60	87		
48-146-54	175	100	146	75	117	F	
48-175-54	210	125	175	100	140		
48-210-54	252	150	210	125	168	FA	
48-250-54	300	200	250	150	200		
48-295-54	354	250	295	200	236	H	
48-365-54	438	300	365	250	292		
48-430-IP	516	350	430	250	344		
48-500-IP	600	400	500	350	400		
48-590-IP	708	500	590	400	472		
48-660-IP	792	550	660	450	528		
48-730-IP	876	600	730	500	584		
48-810-IP	972	700	810	550	648		
48-885-IP	1062	750	885	600	708		
48-1010-IP	1212	800	1010	700	808		
48-1100-IP	1320	900	1100	750	880		
48-1300-IP	1560	1100	1300	800	1040		
48-1460-IP	1752	1250	1460	1000	1168		
48-1710-IP	2052	1500	1710	1200	1368		
48-1820-IP	2184	1600	1820	1250	1456		
48-2190-IP	2628	1900	2190	1500	1752		
48-2550-IP	3060	2100	2550	1700	2040		
48-2920-IP	3504	2500	2920	2000	2336		

Larger sizes available on request

\* Available during limited time and as long as allowed by drive temperature.

\*\* PEBB= Power Electronic Building Block (power module).

## Emotron VFX 2.1 - IP54 version (Model 69-250 and up also available as IP20)

Table 56 Typical motor power at mains voltage 525 V.  
AC drive main voltage range, for VFX52: 440 - 525 V and for VFX69: 500 - 690 V.

Model VFX	Max. output current [A]*	Normal duty (120%, 1 min every 10 min)		Heavy duty (150%, 1 min every 10 min)		Frame size (Number of PEBB's)**	IP class	
		Power @525V [kW]	Rated current [A]	Power @525V [kW]	Rated current [A]			
52-003-54	3.8	1.1	2.5	1.1	2.0	B	IP 54 wall mounted	
52-004-54	6.0	2.2	4.0	1.5	3.2			
52-006-54	9.0	3	6.0	2.2	4.8			
52-008-54	11.3	4	7.5	3	6.0			
52-010-54	14.3	5.5	9.5	4	7.6			
52-013-54	19.5	7.5	13.0	5.5	10.4			
52-018-54	27.0	11	18.0	7.5	14.4			
52-026-54	39	15	26	11	21	C		
52-031-54	46	18.5	31	15	25			
52-037-54	55	22	37	18.5	29.6			
52-046-54	69	30	46	22	37			
52-061-54	92	37	61	30	49	D		
52-074-54	111	45	74	37	59	F69		
69-082-54	98	55	82	45	66			
69-090-54	108	55	90	45	72			
69-109-54	131	75	109	55	87			
69-146-54	175	90	146	75	117			
69-175-54	210	110	175	90	140			
69-200-54	240	132	200	110	160			
69-250-IP	300	160	250	132	200	H69 (2)		IP 20 module or IP54 cabinet
69-300-IP	360	200	300	160	240			
69-375-IP	450	250	375	200	300			
69-400-IP	480	250	400	220	320			
69-430-IP	516	300	430	250	344	I69 (3)		
69-500-IP	600	315	500	300	400			
69-595-IP	720	400	600	315	480			
69-650-IP	780	450	650	355	520	J69 (4)		
69-720-IP	864	500	720	400	576			
69-800-IP	960	560	800	450	640			
69-995-IP	1200	630	1000	500	800		KA69 (5)	
69-1K2-IP	1440	800	1200	630	960	K69 (6)		
69-1K4-IP	1680	1000	1400	800	1120	L69 (7)		
69-1K6-IP	1920	1100	1600	900	1280	M69 (8)		
69-1K8-IP	2160	1300	1800	1000	1440	N69 (9)		
69-2K0-IP	2400	1400	2000	1100	1600	O69 (10)		
69-2K2-IP	2640	1600	2200	1200	1760	P69 (11)		
69-2K4-IP	2880	1700	2400	1400	1920	Q69 (12)		
69-2K6-IP	3120	1900	2600	1500	2080	R69 (13)		
69-2K8-IP	3360	2000	2800	1600	2240	S69 (14)		
69-3K0-IP	3600	2200	3000	1700	2400	T69 (15)		

\* Available during limited time and as long as allowed by drive temperature.

\*\* PEBB= Power Electronic Building Block (power module).

Table 57 Typical motor power at mains voltage 575 and 690 V. AC drive main voltage range 500 - 690 V.

Model VFX	Max. output current [A]*	Normal duty (120%, 1 min every 10 min)			Heavy duty (150%, 1 min every 10 min)			Frame size (Number of PEBB's)**	IP class
		Power @575V [HP]	Power @690V [kW]	Rated current [A]	Power @575V [HP]	Power @690V [kW]	Rated current [A]		
69-033-54	53	30	30	33	25	22	26	D69	IP 54 wall mounted
69-042-54	67	40	37	42	30	30	34		
69-050-54	80	50	45	50	40	37	40		
69-058-54	93	60	55	58	40	45	46		
69-082-54	98	75	75	82	60	55	66		
69-090-54	108	75	90	90	60	75	72	F69	
69-109-54	131	100	110	109	75	90	87		
69-146-54	175	125	132	146	100	110	117		
69-175-54	210	150	160	175	125	132	140		
69-200-54	240	200	200	200	150	160	160		
69-250-IP	300	250	250	250	200	200	200	H69 (2)	IP 20 module or IP54 cabinet
69-300-IP	360	300	315	300	250	250	240		
69-375-IP	450	350	355	375	300	315	300		
69-400-IP	480	400	400	400	300	315	320	I69 (3)	
69-430-IP	516	400	450	430	350	315	344		
69-500-IP	600	500	500	500	400	355	400		
69-595-IP	720	600	600	600	500	450	480	J69 (4)	
69-650-IP	780	650	630	650	550	500	520		
69-720-IP	864	750	710	720	600	560	576	KA69 (5)	
69-800-IP	960	850	800	800	650	630	640		
69-905-IP	1080	950	900	900	750	710	720	K69 (6)	
69-995-IP	1200	1000	1000	1000	850	800	800		
69-1K2-IP	1440	1200	1200	1200	1000	900	960	L69 (7)	
69-1K4-IP	1680	1500	1400	1400	1200	1120	1120		
69-1K6-IP	1920	1700	1600	1600	1300	1250	1280	M69 (8)	
69-1K8-IP	2160	1900	1800	1800	1500	1400	1440		
69-2K0-IP	2400	2100	2000	2000	1700	1600	1600	N69 (9)	
69-2K2-IP	2640	2300	2200	2200	1800	1700	1760		
69-2K4-IP	2880	2500	2400	2400	2000	1900	1920	O69 (10)	
69-2K6-IP	3120	2700	2600	2600	2200	2000	2080		
69-2K8-IP	3360	3000	2800	2800	2400	2200	2240	P69 (11)	
69-3K0-IP	3600	3200	3000	3000	2500	2400	2400		
								Q69 (12)	
								R69 (13)	
								S69 (14)	
								T69 (15)	

\* Available during limited time and as long as allowed by drive temperature.

\*\* PEBB= Power Electronic Building Block (power module).

## 14.2 General electrical specifications

Table 58 General electrical specifications

General	
Mains voltage: VFX48 VFX52 VFX69	230-480 V +10%/-15% (-10% at 230 V) 440-525 V +10 %/-15 % 500-690 V +10%/-15%
Mains frequency:	45 to 65 Hz
Mains voltage imbalance:	max. $\pm 3.0\%$ of nominal phase to phase input voltage.
Input power factor:	0.95
Output voltage:	0-Mains supply voltage:
Output frequency:	0-599 Hz
Output switching frequency: *	3 kHz 2 kHz sizes 48-293/295/365
Efficiency at nominal load:	97% for models 002 to 021 98% for models 025 to 3K0
Control signal inputs: Analogue (differential)	
Analogue Voltage/current: Max. input voltage: Input impedance:	0- $\pm 10$ V/0-20 mA via switch +30 V/30 mA 40 kohm (voltage) 252 ohm (current)
Resolution: Hardware accuracy: Non-linearity	11 bits + sign 1% type + 1 $\frac{1}{2}$ LSB fsd 1 $\frac{1}{2}$ LSB
Digital:	
Input voltage: Max. input voltage: Input impedance:	High: >9 VDC, Low: <4 VDC +30 VDC <3.3 VDC: 4.7 kohm $\geq 3.3$ VDC: 3.6 kohm
Signal delay:	$\leq 8$ ms
Control signal outputs Analogue	
Output voltage/current: Max. output voltage: Short-circuit current ( $\infty$ ): Output impedance: Resolution: Maximum load impedance for current Hardware accuracy: Offset: Non-linearity:	0-10 V/0-20 mA via software setting +13 V @5 mA cont. +160 mA (voltage), +160 mA (current) 0 ohm (voltage) 10 bit 500 ohm 1.9% type fsd (voltage), 2.4% type fsd (current) 3 LSB 2 LSB
Digital	
Output voltage: Short circuit current( $\infty$ ):	High: >20 VDC @50 mA, >23 VDC open Low: <1 VDC @50 mA 100 mA max (together with +24 VDC)
Relays	
Contacts	0.1 – 2 A/Umax 250 VAC or 42 VDC (30 VDC acc. to UL requirement) for general Purpose or Resistive use only .
RS-485 communication	
Differential voltage:	-7 V to 12 V
References	
+10VDC -10VDC +24VDC	+10 V <sub>DC</sub> @10 mA Short-circuit current +30 mA max - 10 V <sub>DC</sub> @10 mA +24 V <sub>DC</sub> Short-circuit current +100 mA max (together with Digital Outputs)
Standby supply	
Standby supply input voltage for control unit.	24 VDC $\pm 10\%$ (max 1A consumption)

\* Internally reduced to minimum 1.5 kHz if IGBT temperature is too high.

## 14.3 Operation at higher temperatures

Most Emotron AC drives are made for operation at maximum of 40 °C (104 °F) ambient temperature. Frame sizes D69/C2(69)/D2(69) are rated at 45 °C (113 °F). However, it is possible to use the AC drive at higher temperatures with reduced output rating.

### 14.3.1 Possible derating

Derating of output current is possible with -1% / degree Celsius to max +15 °C \* (= max temp 55 °C) or -0.55% / degree Fahrenheit to max +27 °F (= max temp. 131 °F).

\* max +10 °C for sizes D69/C2(69)/D2(69)

### Example

In this example we have a motor with the following data that we want to run at the ambient temperature of 45 °C (113 °F):

Voltage 400 V  
Current 72 A  
Power 37 kW (50 hp)

#### Select AC drive

The ambient temperature is 5 °C (9 °F) higher than the maximum ambient temperature. The following calculation is made to select the correct AC drive model.

Derating is possible with loss in performance of 1%/°C (0.55% / degree F).

Derating will be:  $5 \times 1\% = 5\%$

Calculation for model VFX48-074  
 $74 \text{ A} - (5\% \times 74) = 70.3 \text{ A}$ ; this is not enough.

Calculation for model VFX48-090  
 $90 \text{ A} - (5\% \times 90) = 85.5 \text{ A}$

In this example we select the VFX48-090.

## 14.4 Dimensions and Weights

The table below gives an overview of the dimensions and weights. The models 002 to 295 and 365 are available in IP54 as wall mounted modules.

The models 430 to 3K0 consist of 2, 3, 4 .... 15 paralleled power electronic building block (PEBB) available in IP20 intended for cabinet mounting or mounted in IP54 standard cabinet.

Protection class IP54 is according to the EN 60529 standard.

Table 59 Mechanical specifications, VFX48 and VFX52 for IP20 module and IP54

Models VFX48/52	Frame size	IP20 module Dim. H x W x D mm (in)	IP54 Dim. H x W x D mm (in)	IP20 Weight kg (lb)	IP54 Weight kg (lb)
003 to 018	B	–	350/416* x 203 x 200 (13.8/16.4* x 8.0 x 7.9)	–	12.5 (27.6)
026 to 046	C	–	440/512* x 178 x 292 (17.3/20.2* x 7.0 x 11.5)	–	24 (52.9)
061 to 074	D	–	545/590* x 220 x 295 (21.5/23.2* x 8.7 x 11.5)	–	32 (70.6)
90 to 109	E	–	950 x 285 x 314 (37.4 x 11.2 x 12.4)	–	56 (123.5)
146 to 175	E	–	950 x 285 x 314 (37.4 x 11.2 x 12.4)	–	60 (132.3)
210 to 295	F	–	950 x 345 x 314 (37.4 x 13.6 x 12.4)	–	75 (165.4)
365	FA	-	1395 x 345 x 365 (54.9 x 13.6 x 14.4)	-	95 (209)
430 to 500	H	1036 x 500 x 450 (40.8 x 19.7x 17.7)	2200 x 600 x 600** (86.6 x 23.6 x 23.6)	170 (374.8)	380 (837.8)
590	G2	1036 x 500 x 450 (40.8 x 19.7 x 17.7)	2200 x 600 x 600** (86.6 x 23.6 x 23.6)	170 (374.8)	400 (881.9)
660 to 730	H2	1176 x 500 x 450 (46.3 x 19.7 x 17.7)	2200 x 600 x 600** (86.6 x 23.6 x 23.6)	190 (418.9)	420 (925.9)
810 to 885	G3	1036 x 730 x 450 (40.8 x 28.7 x 17.7)	2200 x 1000 x 600** (86.6 x 39.4 x 23.6)	240 (529.1)	550 (1212.5)
1010 to 1100	H3	1176 x 730 x 450 (46.3 x 28.7 x 17.7)	2200 x 1000 x 600** (86.6 x 39.4 x 23.6)	280 (617.3)	590 (1300.7)
1300 to 1460	H4	1176 x (500+500) x 450 (46.3 x (19.7+19.7) x 17.7)	2200 x 1200 x 600** (86.6 x 47.2 x 23.6)	380 (837.8)	840 (1851.9)
1710 to 1820	H5	1176 x (730+500) x 450 (46.3 x (28.7+19.7) x 17.7)	2200 x 1600 x 600** (86.6 x 63.0 x 23.6)	470 (1036.2)	1010 (2226.7)
2190	H6	1176 x (730+730) x 450 (46.3 x (28.7+28.7) x 17.7)	2200 x 2000 x 600** (86.6 x 78.7 x 23.6)	560 (1234.6)	1180 (2601.5)
2550	H7	1176 x (500+730+500) x 450 (46.3 x (19.7+28.7+19.7) x 17.7)	2200 x 2200 x 600** (86.6 x 86.6 x 23.6)	660 (1455.1)	1430 (3152.6)
2920	H8	1176 x (730+500+730) x 450 (46.3 x (28.7+19.7+28.7) x 17.7)	2200 x 2600 x 600** (86.6 x 102.4 x 23.6)	750 (1653.5)	1600 (3527.4)

\* Enclosure height/Total height

\*\* Cabinet has at the door front an extension to hold the inlet filters of around 8 cm, which increases the depth in total to 680 mm.

Table 60 Mechanical specifications, VFX69 for IP20 module and IP54

Models VFX69	Frame size	IP20 module Dim. H x W x D mm (in)	IP54 Dim. H x W x D mm (in)	Weight IP20 kg (lb)	Weight IP54 kg (lb)
033 to 058	D69	-	545/590* x 220 x 282 (21.5/23.2 x 8.7 x 11.1)	-	32 (70.5)
082 to 200	F69	-	1090 x 345 x 312 (42.9 x 13.6 x 12.3)	-	77 (169.8)
250 to 400	H69 (2xF69)	1176 x 500 x 450 (46.3 x 19.7 x 17.7)	2200 x 600 x 600** (86.6 x 23.6 x 23.6)	176 (388)	399 (879.6)
430 to 595	I69 (3xF69)	1176 x 730 x 450 (46.3 x 28.7 x 17.7)	2200 x 1000 x 600** (86.6 x 39.4 x 23.6)	257 (566.6)	563 (1241)
650 to 800	J69 (2xH69)	1176 x 1100 x 450 (46.3 x 43.3 x 17.7)	2200 x 1200 x 600** (86.6 x 47.2 x 23.6)	352 (776)	773 (1704)
905 to 995	KA69 (H69+I69)	1176 x 1365 x 450 (46.3 x 53.7 x 17.7)	2200 x 1600 x 600** (86.6 x 63.0 x 23.6)	433 (954.6)	937 (2066)
750 to 1K2	K69 (2xI69)	1176 x 1630 x 450 (46.3 x 64.2 x 17.7)	2200 x 2000 x 600** (86.6 x 70.9 x 23.6)	514 (1133)	1100 (2425)
1K4	L69 (2xH69+I69)	1176 x 2000 x 450 (46.3 x 78.7 x 17.7)	2200 x 2200 x 600** (86.6 x 86.6 x 23.6)	609 (1343)	1311 (2890)
1K6	M69 (H69+2xI69)	1176 x 2230 x 450 (46.3 x 87.8 x 17.7)	2200 x 3600 x 600** (86.6 x 141.7 x 23.6)	690 (1521)	1481 (3265)
1K8	N69 (3xI69)	1176 x 2530 x 450 (46.3 x 99.6 x 17.7)	2200 x 3000 x 600** (86.6 x 118.1 x 23.6)	771 (1700)	1651 (3640)
2K0	O69 (2xH69+2xI69)	1176 x 2830 x 450 (46.3 x 111.4 x 17.7)	2200 x 3200 x 600** (86.6 x 126.0 x 23.6)	866 (1909)	1849 (4076)
2K2	P69 (H69+3xI69)	1176 x 3130 x 450 (46.3 x 123.2 x 17.7)	2200 x 3600 x 600** (86.6 x 141.7 x 23.6)	947 (2088)	2050 (4519)
2K4	Q69 (4xI69)	1176 x 3430 x 450 (46.3 x 135 x 17.7)	2200 x 4000 x 600** (86.6 x 157.5 x 23.6)	1028 (2266)	2214 (4881)
2K6	R69 (2xH69+3xI69)	1176 x 3730 x 450 (46.3 x 146.9 x 17.7)	2200 x 4200 x 600** (86.6 x 165.4 x 23.6)	1123 (2476)	2423 (5342)
2K8	S69 (H69+4xI69)	1176 x 4030 x 450 (46.3 x 158.7 x 17.7)	2200 x 4600 x 600** (86.6 x 181.1 x 23.6)	1204 (2654)	2613 (5761)
3K0	T69 (5xI69)	1176 x 4330 x 450 (46.3 x 170.5 x 17.7)	2200 x 5000 x 600** (86.6 x 196.8 x 23.6)	1285 (2833)	2777 (6122)

\* Enclosure height/Total height

\*\* Cabinet has at the door front an extension to hold the inlet filters of around 8 cm, which increases the depth in total to 680 mm.

## Dimensions and weights for models Emotron VFX48 - IP20/21 version

The table below gives an overview of the dimensions and weights of the Emotron VFX IP20/21 version.

These AC drives are available as wall mounted modules;  
The IP20 version is optimised for cabinet mounting.  
With the optional top cover, protection class is in compliance with IP21, making it suitable for mounting directly on the electrical room wall.

The protection classes IP20 and IP21 are defined according to the EN 60529 standard.

Table 61 Mechanical specifications, VFX48 - IP20 and IP21 version

Models VFX48	Frame size	IP20 Dim. H1/H2 x W x D mm (in)	IP21* Dim. H1/H2 x W x D mm (in)	IP20/21 Weight kg (lb)
025 to 058	C2	438 / 536 x 176 x 267 (17.2 / 21.1 x 6.9 x 10.5)	438 / 559 x 196 x 282 (17.2 / 22 x 7.7 x 11.1)	17 (37.5)
060 to 105	D2	545 / 658 x 220 x 291 (21.5 / 25.9 x 8.7 x 11.5)	545 / 670 x 240 x 307 (21.5 / 26.4 x 9.5 x 12.1)	30 (66)
142 and 171	E2	956 / 956 x 275 x 294 (37.6 / 37.6 x 10.8 x 11.6)	956 / 956 x 275 x 323 (37.6 / 37.6 x 10.8 x 12.7)	53 (117)
145 and 174	E4	822 / 822 x 263 x 318 (32.4 x 10.4 x 12.5)	-	
205 to 293	F2	956 / 956 x 335 x 294 (37.6 / 37.6 x 13.2 x 11.6)	956 / 956 x 335 x 323 (37.6 / 37.6 x 13.2 x 12.7)	69 (152)
365	FA2	1090 / 1250 x 335 x 306 (42.9 / 49.5 x 13.2 x 12.1)	-	84 (185)

H1 = Enclosure height.

H2 = Total height including cable interface.

\* with optional top cover

---

**NOTE: The frame size E4 is only available on the Indian market and is not UL or Marine approved.**

---

Table 62 Mechanical specifications, VFX69 - IP20 and IP21 version

Models VFX69	Frame size	IP20 Dim. H1/H2 x W x D mm (in)	IP20 Weight kg (lb)
033 to 058	D2(69)	545 / 658 x 220 x 291 (21.5 / 25.9 x 8.7 x 11.5)	30 (66)

H1 = Enclosure height.

H2 = Total height including cable interface.

\* with optional top cover

## 14.5 Environmental conditions

Table 63 Operation

Parameter	Normal operation
Nominal ambient temperature	0 °C–40 °C (32 °F - 104 °F) See Section 14.3 page 239 for different conditions 0 °C - 45 °C (32 °F - 113 °F) for sizes C69/D69/C2(69)/D2(69)
Atmospheric pressure	86–106 kPa (12.5 - 15.4 PSI)
Relative humidity, according to IEC 60721-3-3	Class 3K4, 5...95% and non condensing
Contamination, according to IEC 60721-3-3	No electrically conductive dust allowed. Cooling air must be clean and free from corrosive materials. Chemical gases, class 3C3 (coated boards standard). Solid particles, class 3S2.
Vibrations	According to IEC 60068-2-6, Sinusoidal vibrations: 10<f<57 Hz, 0.075 mm (0.00295 ft) 57<f<150 Hz, 1g (0,035 oz)
Altitude	0–1000 m (0 - 3280 ft) 480V AC drives, with derating 1%/100 m (328 ft) of rated current up to 4000 m (13123 ft) 690V AC drives, with derating 1%/100 m (328 ft) of rated current up to 2000 m (6562) ft Coated boards required for 2000 - 4000 m(6562 - 13123 ft)

Table 64 Storage

Parameter	Storage condition
Temperature	-20 to +60 °C (-4 to + 140 °F)
Atmospheric pressure	86–106 kPa (12.5 - 15.4 PSI)
Relative humidity, according to IEC 60721-3-1	Class 1K4, max. 95% and non condensing and no formation of ice.



**WARNING!**

If the device is stored for more than two years, the DC link capacitor of the devices must be reformed during commissioning.

The reforming procedure is described in manual "Capacitor reforming unit".

## 14.6 Fuses and glands

### 14.6.1 According to IEC ratings

Use mains fuses of the type gL/gG conforming to IEC 269 or breakers with similar characteristics. Check the equipment first before installing the glands.

Max. Fuse = maximum fuse value that still protects the AC drive and upholds warranty.

**NOTE: The dimensions of fuse and cable cross-section are dependent on the application and must be determined in accordance with local regulations.**

**NOTE: The dimensions of the power terminals used in the cabinet drive models 430 to 3K0 can differ depending on customer specification.**

Table 65 Fuses, cable cross-sections and glands for VFX48 and VFX52 models

Model VFX	Nominal input current [A]	Maximum value fuse [A]	Cable glands (clamping range) *	
			mains / motor	Brake
###-003-54	2.2	4	M32 opening M20 + reducer (6–12 mm(0.24 - 0.47 in))	M25 opening M20 + reducer (6–12 mm(0.24 - 0.47 in))
##-004-54	3.5	4		
##-006-54	5.2	6		
##-008-54	6.9	10	M32 (12–20)/M32 opening M25+reducer (10-14 mm(0.39 - 0.55 in))	M25 (10-14 mm(0.39 - 0.55 in))
##-010-54	8.7	10		
##-013-54	11.3	16	M32 (16–25)/M32 (13–18)	
##-018-54	15.6	20		
48-025-20	22	25	- (12 - 16 mm(0.55 - 0.63 in))	
##-026-54	22	25	M32 (15–21 mm(0.59 - 0.83 in))	M25
48-030-20	26	35	- (16 - 20 mm (0.63 - 0.79 in))	
##-031-54	26	35	M32 (15–21 mm(0.59 - 0.83 in))	M25
48-036-20	31	35	- (20 - 24 mm(0.79 - 0.94))	
##-037-54	31	35	M40 (19–28 mm (0.75 - 1.1 in))	M32
48-045-20	38	50	- (24 - 28 mm(0.94 - 1.1 in))	
##-046-54	38	50	M40 (19–28 mm (0.75 - 1.1 in))	M32
48-058-20	50	63	- (24 - 28 mm(0.94 - 1.1 in))	
48-060-20	52	63	- (28 - 32 mm(1.1 - 1.26 in))	
##-061-54	52	63	M50 (27 - 35 mm(1.06 - 1.38 in))	M40 (19–28 mm (0.75 - 1.1 in))
48-072-20	64	80	- (28 - 32 mm(1.1 - 1.26 in))	
##-074-54	65	80	M50 (27 - 35 mm(1.06 - 1.38 in))	M40 (19–28 mm(0.75 - 1.1 in))
48-088-20	78	100	- (32 - 36 mm(1.26 - 1.42 in))	
48-090-54	78	100	(Ø17-42 mm (0.67 - 1.65 in)) cable flexible leadthrough or M50 opening.	(Ø11-32 mm(0.43 - 1.26 in)) Cable flexible leadthrough or M40 opening.
48-105-20	91	100	(32 - 36 mm(1.26 - 1.42 in))	
48-109-54	94	100	(Ø17-42 mm (0.67 - 1.65 in)) cable flexible leadthrough or M50 opening	(Ø11-32 mm(0.43 - 1.26 in)) Cable flexible leadthrough or M40 opening

Table 65 Fuses, cable cross-sections and glands for VFX48 and VFX52 models

Model VFX	Nominal input current [A]	Maximum value fuse [A]	Cable glands (clamping range) *	
			mains / motor	Brake
48-142-20	126	160	- (40 - 44 mm (1.57 - 1.73 in))	- (36 - 40 mm(1.42 - 1.57 in))
48-146-54	126	160	(Ø17-42 mm (0.67 - 1.65 in)) cable flexible leadthrough or M50 opening.	(Ø11-32 mm(0.43 - 1.26 in)) Cable flexible leadthrough or M40 opening.
48-171-20	152	160	- (40 - 44 mm (1.57 - 1.73 in))	- (36 - 40 mm(1.42 - 1.57 in))
48-175-54	152	160	(Ø17-42 mm (0.67 - 1.65 in)) cable flexible leadthrough or M50 opening.	(Ø11-32 mm(0.43 - 1.26 in)) Cable flexible leadthrough or M40 opening.
48-205-20	178	200	- (48 - 52 mm(1.89 - 2.05 in)/ 52 - 56 mm (2.05 - 2.2 in))	- (44 - 48 mm (1.73 - 1.89 in))
48-210-54	182	200	(Ø23 - 55 mm (0.9 - 2.16 in)) cable flexible leadthrough or M63 opening.	(Ø17- 42 mm (0.67 - 1.65 in)) cable flexible leadthrough or M50 opening.
48-244-20	211	250	- (48 - 52 mm (1.89 - 2.05 in)/ 52 - 56 mm (2.05 - 2.2 in))	- (44 - 48 mm (1.73 - 1.89 in))
48-250-54	216	250	(Ø 23 - 55 mm (0.9 - 2.16 in)) cable flexible leadthrough or M63 opening.	(Ø 23 - 55 mm (0.9 - 2.16 in)) cable flexible leadthrough or M63 opening.
48-295-54	256	300		
48-293-20	254	300	- (48 - 52 mm (1.89 - 2.05 in)/ 52 - 56 mm (2.05 - 2.2 in))	- (44 - 48 mm (1.73 - 1.89 in))
48-365-20	324	355	M10 bolt for cable lugs	M8 bolt for cable lugs
48-365-54	324	355	(Ø 23 - 55 mm (0.9 - 2.16 in)) cable flexible leadthrough or M63 opening.	(Ø 23 - 55 mm (0.9 - 2.16 in)) cable flexible leadthrough or M63 opening.
48-430-IP	372	400	Non-applicable	Non-applicable
48-500-IP	432	500		
48-590-IP	513	630		
48-660-IP	574	630		
48-730-IP	635	710		
48-810-IP	705	800		
48-885-IP	770	900		
48-1010-IP	879	1000		
48-1100-IP	957	1250		
48-1300-IP	1131	1250		
48-1460-IP	1270	1500		
48-1710-IP	1488	1600		
48-1820-IP	1583	2 x 900		
48-2190-IP	1905	2 x 1000		
48-2550-IP	2219	2 x 1250		
48-2920-IP	2540	2 x 1500		

**NOTE:** For IP54 models 48/52-003 to -074 and 69-002 to -058 cable glands are optional.

\* IP20/21 models are equipped with cable clamps instead of glands.

\*\*##=VFX48 and VFX52

For data on cable connection ranges, see Section 3.4.3, page 42.

Table 66 Fuses, cable cross-sections and glands for 690V models

Model VFX	Nominal input current [A]	Maximum value fuse [A]	Cable glands (clamping range) *	
			mains / motor	Brake
69-002-54	1.6	4	M32 (8 - 17 / 9 - 17 mm)	M25 (9 - 17 mm)
69-002-20	1.6	4	8 - 12 mm (0.32 - 0.47 in) 12 - 16 mm (0.47 - 0.63 in)	
69-003-54	2.3	4	M32 (8 - 17 / 9 - 17 mm)	M25 (9 - 17 mm)
69-003-20	2.3	4	8 - 12 mm (0.32 - 0.47 in) 12 - 16 mm (0.47 - 0.63 in)	
69-004-54	3.1	4	M32 (8 - 17 / 9 - 17 mm)	M25 (9 - 17 mm)
69-004-20	3.1	4	8 - 12 mm (0.32-0.47 in) 12 - 16 mm (0.47-0.63 in)	
69-006-54	4.7	6	M32 (8 - 17 / 9 - 17 mm)	M25 (9 - 17 mm)
69-006-20	4.7	6	8 - 12 mm (0.32 - 0.47 in) 12 - 16 mm (0.47 - 0.63 in)	
69-008-54	6.3	10	M32 (8-17 / 9 - 17 mm)	M25 (9 - 17 mm)
69-008-20	6.3	10	8 - 12 mm (0.32 - 0.47 in) 12 - 16 mm (0.47 - 0.63 in)	
69-010-54	7.8	10	M32 (8-17 / 9 - 17 mm)	M25 (9 - 17 mm)
69-010-20	7.8	10	8 - 12 mm (0.32 - 0.47 in) 12 - 16 mm (0.47 - 0.63 in)	
69-013-54	10.4	16	M32 (9 - 21 / 11 - 21 mm)	M25 (9 - 17 mm)
69-013-20	10.4	16	12 - 16 mm (0.47 - 0.63 in) 16 - 22 mm (0.63 - 0.87 in)	
69-018-54	15.3	20	M32 (9 - 21 / 11 - 21 mm)	M25 (9 - 17 mm)
69-018-20	15.3	20	12 - 16 mm (0.47 - 0.63 in) 16 - 22 mm (0.63 - 0.87 in)	
69-021-54	17.8	25	M32 (9 - 21 / 11 - 21 mm)	M25 (9 - 17 mm)
69-021-20	17.8	25	12 - 16 mm (0.47 - 0.63 in) 16 - 22 mm (0.63 - 0.87 in)	
69-025-54	21.2	25	M32 (9-21 / 11-21 mm)	M25 (9 - 17 mm)
69-025-20	21.2	25	12 - 16 mm (0.47 - 0.63 in) 16 - 22 mm (0.63 - 0.87 in)	
69-033-54	28	35	M50 (19 - 28 / 16 - 28 mm)	M40 (16 - 28 mm)
69-033-20	28	35	16 - 22 mm (0.63 - 0.87 in) 22 - 28 mm (0.87 - 1.1 in)	
69-042-54	36	50	M50 (19 - 28 / 16-28 mm)	M40 (16 - 28 mm)
69-042-20	36	50	16 - 22 mm (0.63 - 0.87 in) 22 - 28 mm (0.87 - 1.1 in)	
69-050-54	43	63	M50 (19 - 28 / 16 - 28 mm)	M40 (16 - 28 mm)
69-050-20	43	63	16 - 22 mm (0.63 - 0.87 in) 22 - 28 mm (0.87 - 1.1 in)	
69-058-54	49	63	M50 (19 - 28 / 16 - 28 mm)	M40 (16 - 28 mm)
69-058-20	49	63	16 - 22 mm (0.63 - 0.87 in) 22 - 28 mm (0.87 - 1.1 in)	

Table 66 Fuses, cable cross-sections and glands for 690V models

Model VFX	Nominal input current [A]	Maximum value fuse [A]	Cable glands (clamping range) *	
			mains / motor	Brake
69-082-54	72	100		
69-090-54	78	100		
69-109-54	94	100		
69-146-54	126	160		
69-175-54	152	160		
69-200-54	173	200		
69-250-IP	216	250		
69-300-IP	260	300	Non-applicable	Non-applicable
69-375-IP	324	355		
69-400-IP	346	400		
69-430-IP	372	400		
69-500-IP	432	500		
69-595-IP	516	630		
69-650-IP	562	630		
69-720-IP	648	710		
69-800-IP	692	800		
69-905-IP	795	900		
69-995-IP	864	1000		
69-1K2-IP	1037	1250		
69-1K4-IP	1213	1500		
69-1K6-IP	1382	1600		
69-1K8-IP	1555	2 x 900		
69-2K0-IP	1732	2 x 900		
69-2K2-IP	1900	2 x 1000		
69-2K4-IP	2074	2 x 1250		
69-2K6-IP	2246	2 x 1250		
69-2K8-IP	2419	2 x 1500		
69-3K0-IP	2592	2 x 1500		

**NOTE:** For IP54 models 48/52-003 to -074 and 69-002 to -058 cable glands are optional.

\* IP20/21 models are equipped with cable clamps instead of glands.

For data on cable connection ranges, see Section 3.4.3, page 42.

## 14.6.2 Fuses according to NEMA ratings

Table 67 Types and fuses

Model VFX	Input current [Arms]	Mains input fuses	
		UL Class J TD (A)	Ferraz-Shawmut type
48-003	2.2	6	AJT6
48-004	3.5	6	AJT6
48-006	5.2	6	AJT6
48-008	6.9	10	AJT10
48-010	8.7	10	AJT10
48-013	11.3	15	AJT15
48-018	15.6	20	AJT20
48-025	21.7	25	AJT25
48-026	22	25	AJT25
48-030	26	30	AJT30
48-031	26	30	AJT30
48-036	31	35	AJT35
48-037	31	35	AJT35
48-045	39	45	AJT45
48-046	40	45	AJT45
48-058	50	60	AJT60
48-060	52	60	AJT60
48-061	52	60	AJT60
48-072	64	80	AJT80
48-074	65	80	AJT80
48-088	78	100	AJT100
48-090	78	100	AJT100
48-105	91	110	AJT110
48-109	94	110	AJT110
48-142	126	125	AJT150
48-146	126	150	AJT150
48-171	152	175	AJT175
48-175	152	175	AJT175
48-205	178	200	AJT200
48-210	182	200	AJT200
48-244	211	250	AJT250
48-250	216	250	AJT250
48-293	254	300	AJT300
48-295	256	300	AJT300
48-365	324	350	AJT350
48-430	372	400	AJT400
48-500	432	500	AJT500

Table 67 Types and fuses

Model VFX	Input current [Arms]	Mains input fuses	
		UL Class J TD (A)	Ferraz-Shawmut type
48-590	513	600	AJT600
48-660	574	600	AJT600
48-730	635	700	AJT700
48-810	705	800	A4BQ800
48-885	770	800	A4BQ800
48-1010	879	1000	A4BQ1000
48-1100	957	1000	A4BQ1000
48-1300	1131	1200	A4BQ1200
48-1460	1270	1500	A4BQ1500
48-1710	1488	1600	A4BQ1600
48-1820	1583	1600	A4BQ1600
48-2190	1905	2000	A4BQ2000
48-2550	2219	2500	A4BQ2500
48-2920	2540	3000	A4BQ3000

## 14.7 Control signals

Table 68

Terminal X1	Name:	Function (Default):	Signal:	Type:
1	+10 V	+10 VDC Supply voltage	+10 VDC, max 10 mA	output
2	AnIn1	Process reference	0 -10 VDC or 0/4-20 mA bipolar: -10 - +10 VDC or -20 - +20 mA	analogue input
3	AnIn2	Off	0 -10 VDC or 0/4-20 mA bipolar: -10 - +10 VDC or -20 - +20 mA	analogue input
4	AnIn3	Off	0 -10 VDC or 0/4-20 mA bipolar: -10 - +10 VDC or -20 - +20 mA	analogue input
5	AnIn4	Off	0 -10 VDC or 0/4-20 mA bipolar: -10 - +10 VDC or -20 - +20 mA	analogue input
6	-10 V	-10VDC Supply voltage	-10 VDC, max 10 mA	output
7	Common	Signal ground	0 V	output
8	DigIn 1	RunL	0-8/24 VDC	digital input
9	DigIn 2	RunR	0-8/24 VDC	digital input
10	DigIn 3	Off	0-8/24 VDC	digital input
11	+24 V	+24VDC Supply voltage	+24 VDC, 100 mA	output
12	Common	Signal ground	0 V	output
13	AnOut 1	Min speed to max speed	0 ±10 VDC or 0/4- +20 mA	analogue output
14	AnOut 2	0 to max torque	0 ±10 VDC or 0/4- +20 mA	analogue output
15	Common	Digital signal ground	0 V via ferrite	output
16	DigIn 4	Off	0-8/24 VDC	digital input
17	DigIn 5	Off	0-8/24 VDC	digital input
18	DigIn 6	Off	0-8/24 VDC	digital input
19	DigIn 7	Off	0-8/24 VDC	digital input
20	DigOut 1	Ready	24 VDC, 100 mA	digital output
21	DigOut 2	Brake	24 VDC, 100 mA	digital output
22	DigIn 8	RESET	0-8/24 VDC	digital input
A+		RS-485 transmit and receive signals	Isolated with differential RS-485 voltage levels.	Common mode voltage range -7V to 12V.
B-				
<b>Terminal X2</b>				
31	N/C 1	Relay 1 output	potential free change over 0.1 – 2 A $U_{max} = 250 \text{ VAC}$ or 42 VDC	relay output
32	COM 1	Trip, active when the AC drive is in a TRIP condition		
33	N/O 1	N/C is opened when the relay is active (valid for all relays) N/O is closed when the relay is active (valid for all relays)		
41	N/C 2	Relay 2 Output	potential free change over 0.1 – 2 A $U_{max} = 250 \text{ VAC}$ or 42 VDC	relay output
42	COM 2	Run, active when the AC drive is started		
43	N/O 2			
<b>Terminal X3</b>				
51	COM 3	Relay 3 Output	potential free change over 0.1 – 2 A $U_{max} = 250 \text{ VAC}$ or 42 VDC	relay output
52	N/O 3	Off		
<b>Terminal X11</b>				
+	24 VDC±10%	Input from 24 VDC ±10% double isolated transformer capable of supplying 1A continuous current. Recommended fuse is 2A.		input
-	0 V in			

**NOTE:** Possible potentiometer value in range of 1 k $\Omega$  to 10 k $\Omega$  (¼ Watt) linear, where we advice to use a linear 1 k $\Omega$  / ¼ W type potentiometer for best control linearity.



# 15. Menu List

In the download area on our website, [www.cgglobal.com](http://www.cgglobal.com) or [www.emotron.com](http://www.emotron.com), you find a communication information list and a list for noting parameter set information.

Menu Parameters		Default settings	Modbus Instance/ Device Net No.	Profibus slot/index	EtherCAT index (HEX)	Profinet index	Fieldbus format	Modbus format	Notes
100	Start Window [100]								
110	1st Line	Process Val	43001	168/160	4BB9	19385	UInt	UInt	
120	2nd Line	Current	43002	168/161	4BBA	19386	UInt	UInt	
130	3rd Line	Frequency	43003	168/162	4BBB	19387	UInt	UInt	
140	4th Line	VSD Status	43004	168/163	4BBC	19388	UInt	UInt	
150	5th Line	DC Voltage	43005	168/164	4BBD	19389	UInt	UInt	
160	6th Line	IGBT Temp	43006	168/165	4BBE	19390	UInt	UInt	
170	View mode	Normal 100	43007	168/166	4BBF	19391	UInt	UInt	
200	Main Setup [200]								
210	Operation [210]								
211	Language	English	43011	168/170	4BC3	19395	UInt	UInt	
212	Select Motor	M1	43012	168/171	4BC4	19396	UInt	UInt	
213	Drive Mode	Speed	43013	168/172	4BC5	19397	UInt	UInt	
214	Ref control	Remote	43014	168/173	4BC6	19398	UInt	UInt	
215	Run/Stop Ctrl	Remote	43015	168/174	4BC7	19399	UInt	UInt	
216	Reset Ctrl	Remote+Keyb	43016	168/175	4BC8	19400	UInt	UInt	
217	Local/Remote key function [217]								
2171	LocRefCtrl	Standard	43009	168/168	4BC1	19393	UInt	UInt	
2172	LocRunCtrl	Standard	43010	168/169	4BC2	19394	UInt	UInt	
218	Lock code?	0	43018	168/177	4BCA	19402	UInt, 1=1	UInt	
219	Rotation	R+L	43019	168/178	4BCB	19403	UInt	UInt	
21A	Level/Edge	Level	43020	168/179	4BCC	19404	UInt	UInt	
21B	Supply Volts	Not Defined	43381	170/30	4D35	19765	UInt	UInt	
21C	Supply Type	AC Supply	43382	170/31	4D36	19766	UInt	UInt	
21D	Fire Mode	Off	49333	193/117	6475	25717	UInt	UInt	
21E	CP Units								
21E1	CP Unit Torq	Nm	43383	170/32	4D37	19767	UInt	UInt	
21E2	CP Unit Pow	W	43384	170/33	4D38	19768	UInt	UInt	
21E3	CP Unit Temp	°C	43385	170/34	4D39	19769	UInt	UInt	
220	Motor Data [220]								
221	Motor Volts	[Motor] V	43041	168/200	4BE1	19425	Long, 1=0.1V	EInt	
222	Motor Freq	50Hz	43060	168/219	4BF4	19444	Long, 1=0.1Hz	EInt	
223	Motor Power	[Motor] W	43043	168/202	4BE3	19427	Long, 1=1W	EInt	

Menu Parameters		Default settings	Modbus Instance/ Device Net No.	Profibus slot/index	EtherCAT index (HEX)	Profinet index	Fieldbus format	Modbus format	Notes
224	Motor Curr	[Motor] A	43044	168/203	4BE4	19428	Long, 1=0.1A	Elnt	
225	Motor Speed	[Motor] rpm	43045	168/204	4BE5	19429	Uln, 1=1rpm	Uln	
226	Motor Poles	[Motor]	43046	168/205	4BE6	19430	Long, 1=1	Elnt	
227	Motor Cosφ	[Motor]	43047	168/206	4BE7	19431	Long, 1=0.01	Elnt	
228	Motor Vent	Self	43048	168/207	4BE8	19432	Uln	Uln	
229	Motor ID-Run	Off	43049	168/208	4BE9	19433	Uln	Uln	
22A	Motor Sound	F	43050	168/209	4BEA	19434	Uln	Uln	
22B	Encoder	Off	43051	168/210	4BEB	19435	Uln	Uln	
22C	Enc Pulses	1024	43052	168/211	4BEC	19436	Long, 1=1	Elnt	
22D	Enc Speed	Orpm	42911	168/70	4B5F	19295	Int, 1=1rpm	Int	
22E	Motor PWM [22E]								
22E1	PWM Fswitch	3000Hz	43053	168/212	4BED	19437	Uln, 1=1Hz	Uln	
22E2	Sinus Filter								
22E21	PWM Mode	Standard	43054	168/213	4BEE	19438	Uln	Uln	
22E22	Inductor L1	0μH	43028	168/187	4BD4	19412	Uln, 1=1μH	Uln	
22E23	Capacitor C1	0μF	43029	168/188	4BD5	19413	Uln, 1=1μF	Uln	
22E3	PWM Random	Off	43055	168/214	4BEF	19439	Uln	Uln	
22E4	Udc filter	Off	43040	168/199	4BE0	19424	Uln	Uln	
22F	Enc Puls Ctr	0	42912	168/71	4B60	19296	Long, 1=1	Int	
22G	Encoder fault and speed monitoring [22G]								
22G1	Enc F Delay	Off	43056	168/215	4BF0	19440	Long, 1=0.01s	Elnt	
22G2	Enc F Band	10%	43057	168/216	4BF1	19441	Long, 1=1%	Elnt	
22G3	Max EncFctr	0.000s	42913	168/72	4B61	19297	Long, 1=0.001s	Elnt	
22G4	EncOverrule	Off	43068	168/227	4BFC	19452	Uln	Uln	
22H	Phase order	Normal	43058	168/217	4BF2	19442	Uln	Uln	
22I	Motor Type	Async	43059	168/218	4BF3	19443	Uln	Uln	
22J	Extend data [22J]								
22J1	BEMF	[Motor] V	43391	170/40	4D3F	19775	Long, 1=0.1V	Elnt	
22J2	Rs (mΩ/ph)	[Motor]	43392	170/41	4D40	19776	Long, 1=0.000001	Elnt	
22J3	Lsd (mH/ph)	[Motor]	43393	170/42	4D41	19777	Long, 1=0.001	Elnt	
22J4	Lsq (mH/ph)	[Motor]	43394	170/43	4D42	19778	Long, 1=0.001	Elnt	
230	Mot Protect								
231	Mot I2t Type	Trip	43061	168/220	4BF5	19445	Uln	Uln	
232	Mot I2t Curr	100%	43062	168/221	4BF6	19446	Long, 1=1%	Elnt	
233	Mot I2t Time	60s	43063	168/222	4BF7	19447	Long, 1=1s	Elnt	
234	Thermal Prot	Off	43064	168/223	4BF8	19448	Uln	Uln	

Menu Parameters		Default settings	Modbus Instance/ Device Net No.	Profibus slot/index	EtherCAT index (HEX)	Profinet index	Fieldbus format	Modbus format	Notes
235	Motor Class	F 140 °C	43065	168/224	4BF9	19449	UInt	UInt	
236	PT100 Inputs	PT100 1+2+3	43066	168/225	4BFA	19450	UInt	UInt	
237	Motor PTC	Off	43067	168/226	4BFB	19451	UInt	UInt	
238	I <sup>2</sup> t Min Spd	Orpm	43386	170/35	4D3A	19770	Int, 1=1rpm	Int	
240	Parameter Set Handling [240]								
241	Select Set	A	43022	168/181	4BCE	19406	UInt	UInt	
242	Copy Set	A>B	43021	168/180	4BCD	19405	UInt	UInt	
243	Default>Set	A	43023	168/182	4BCF	19407	UInt	UInt	
244	Copy to CP	No Copy	43024	168/183	4BD0	19408	UInt	UInt	
245	Load from CP	No Copy	43025	168/184	4BD1	19409	UInt	UInt	
246	ComFit Set	Keep last	42653	167/67	4A5D	19037	UInt	UInt	
247	AnInFit Set	Keep last	42654	167/68	4A5E	19038	UInt	UInt	
250	Trip Autoreset/ Trip Conditions [250]								
251	Autores Ctrl								
2511	No of Trips	0	43071	168/230	4BFF	19455	UInt, 1=1	UInt	
2512	Autores Enb	DigIn	43069	168/228	4BFD	19453	UInt	UInt	
252	DriveProtect								
2521	Over temp	Off	43072	168/231	4C00	19456	Long, 1=1s	Elnt	
2522	Over volt D	Off	43075	168/234	4C03	19459	Long, 1=1s	Elnt	
2523	Over volt G	Off	43076	168/235	4C04	19460	Long, 1=1s	Elnt	
2524	Over volt	Off	43077	168/236	4C05	19461	Long, 1=1s	Elnt	
2525	Undervoltage	Off	43088	168/247	4C10	19472	Long, 1=1s	Elnt	
2526	Over curr F	Off	43082	168/241	4C0A	19466	Long, 1=1s	Elnt	
2527	Power Fault	Off	43087	168/246	4C0F	19471	Long, 1=1s	Elnt	
2528	LC Level	Off	43099	169/3	4C1B	19483	Long, 1=1s	Elnt	
2529	LC Level TT	Trip	43100	169/4	4C1C	19484	UInt	UInt	
253	MotorProtect								
2531	Motor Lost	Off	43083	168/242	4C0B	19467	Long, 1=1s	Elnt	
2532	Locked Rotor	Off	43086	168/245	4C0E	19470	Long, 1=1s	Elnt	
2533	Motor I <sup>2</sup> t	Off	43073	168/232	4C01	19457	Long, 1=1s	Elnt	
2534	Motor I <sup>2</sup> t TT	Trip	43074	168/233	4C02	19458	UInt	UInt	
2535	PT100	Off	43078	168/237	4C06	19462	Long, 1=1s	Elnt	
2536	PT100 TT	Trip	43079	168/238	4C07	19463	UInt	UInt	
2537	PTC	Off	43084	168/243	4C0C	19468	Long, 1=1s	Elnt	
2538	PTC TT	Trip	43085	168/244	4C0D	19469	UInt	UInt	
2539	Over speed	Off	43096	169/0	4C18	19480	Long, 1=1s	Elnt	

Menu Parameters		Default settings	Modbus Instance/ Device Net No.	Profibus slot/index	EtherCAT index (HEX)	Profinet index	Fieldbus format	Modbus format	Notes
253A	Ext Mot Temp	Off	43097	169/1	4C19	19481	Long, 1=1s	Elnt	
253B	Ext Mot TT	Trip	43098	169/2	4C1A	19482	Ulnr	Ulnr	
253C	Brk Fault	Off	43070	168/229	4BFE	19454	Long, 1=1s	Elnt	
253D	Encoder	Off	43561	170/210	4DE9	19945	Long, 1=1s	Elnt	
253E	Torque Limitation Trip	Off	43573	170/222	4DF5	19957	Long, 1=1s	Elnt	
253F	Torque Limitation Trip Type	Trip	43574	170/223	4DF6	19958	Ulnr	Ulnr	
254	Comm & I/O								
2541	Com Error	Off	43089	168/248	4C11	19473	Long, 1=1s	Elnt	
2542	Com Error TT	Trip	43090	168/249	4C12	19474	Ulnr	Ulnr	
2543	AnIn<Offset	Off	43566	170/215	4DEE	19950	Long, 1=1s	Elnt	
2544	AnIn TT	Trip	43567	170/216	4DEF	19951	Ulnr	Ulnr	
255	Load monitor								
2551	Min Alarm	Off	43091	168/250	4C13	19475	Long, 1=1s	Elnt	
2552	Min Alarm TT	Trip	43092	168/251	4C14	19476	Ulnr	Ulnr	
2553	Max Alarm	Off	43093	168/252	4C15	19477	Long, 1=1s	Elnt	
2554	Max Alarm TT	Trip	43094	168/253	4C16	19478	Ulnr	Ulnr	
256	Pump								
2561	Pump	Off	43095	168/254	4C17	19479	Long, 1=1s	Elnt	
257	Crane								
2571	Crane Deviat	Off	43562	170/211	4DEA	19946	Long, 1=1s	Elnt	
2572	Crane Comm	Off	43563	170/212	4DEB	19947	Long, 1=1s	Elnt	
258	External								
2581	Ext Trip 1Ext Trip 1	Off	43080	168/239	4C08	19464	Long, 1=1s	Elnt	
2582	Ext Trip1 TTExtTrip1 TT	Trip	43081	168/240	4C09	19465	Ulnr	Ulnr	
2583	Ext Trip 2	Off	43564	170/213	4DEC	19948	Long, 1=1s	Elnt	
2584	Ext Trip2 TT	Trip	43565	170/214	4DED	19949	Ulnr	Ulnr	
2585	Ext Trip 3	Off	43568	170/217	4DF0	19952	Long, 1=1s	Elnt	
2586	Ext Trip3 TT	Trip	43569	170/218	4DF1	19953	Ulnr	Ulnr	
2587	Ext Trip 4	Off	43570	170/219	4DF2	19954	Long, 1=1s	Elnt	
2588	Ext Trip4 TT	Trip	43571	170/220	4DF3	19955	Ulnr	Ulnr	
260	Serial Communication [260]								
261	Com Type	RS232/485	43031	168/190	4BD7	19415	Ulnr	Ulnr	
262	RS232/485								
2621	Baudrate	9600	43032	168/191	4BD8	19416	Ulnr	Ulnr	
2622	Address	1	43033	168/192	4BD9	19417	Ulnr, 1=1	Ulnr	
263	Fieldbus								

Menu Parameters		Default settings	Modbus Instance/ Device Net No.	Profibus slot/index	EtherCAT index (HEX)	Profinet index	Fieldbus format	Modbus format	Notes
2631	Address	62	43034	168/193	4BDA	19418	UInt, 1=1	UInt	
2632	PrData Mode	Basic	43035	168/194	4BDB	19419	UInt	UInt	
2633	Read/Write	RW	43036	168/195	4BDC	19420	UInt	UInt	
2634	AddPrValues	0	43039	168/198	4BDF	19423	UInt, 1=1	UInt	
2635	CANBaudrate	8	43030	168/189	4BD6	19414	UInt, 1=1	UInt	
264	Communication Fault [264]								
2641	ComFit Mode	Off	43037	168/196	4BDD	19421	UInt	UInt	
2642	ComFit Time	0,5s	43038	168/197	4BDE	19422	Long, 1=0.1s	EInt	
2643	485Fit Mode	Off	42979	168/138	4BA3	19363	UInt	UInt	
2644	485Fit Time	0,5s	42980	168/139	4BA4	19364	Long, 1=0.1s	EInt	
2645	KbdComFMode	Trip	42981	168/140	4BA5	19365	UInt	UInt	
2646	KbdComFTime	2s	42982	168/141	4BA6	19366	UInt, 1=0.1s	UInt	
2647	CPportFMode	Trip	42983	168/142	4BA7	19367	UInt	UInt	
2648	CPportFTime	10.0s	42984	168/143	4BA8	19368	UInt, 1=0.1s	UInt	
265	Ethernet [265]								
2651	IP Address	0.0.0.0	42701	167/115	4A8D	19085	UInt, 1=1	UInt	
			42702	167/116	4A8E	19086	UInt, 1=1	UInt	
			42703	167/117	4A8F	19087	UInt, 1=1	UInt	
			42704	167/118	4A90	19088	UInt, 1=1	UInt	
2652	MAC Address	000000000000	42705	167/119	4A91	19089	UInt, 1=1	UInt	
			42706	167/120	4A92	19090	UInt, 1=1	UInt	
			42707	167/121	4A93	19091	UInt, 1=1	UInt	
			42708	167/122	4A94	19092	UInt, 1=1	UInt	
			42709	167/123	4A95	19093	UInt, 1=1	UInt	
			42710	167/124	4A96	19094	UInt, 1=1	UInt	
2653	Subnet Mask	0.0.0.0	42711	167/125	4A97	19095	UInt, 1=1	UInt	
			42712	167/126	4A98	19096	UInt, 1=1	UInt	
			42713	167/127	4A99	19097	UInt, 1=1	UInt	
			42714	167/128	4A9A	19098	UInt, 1=1	UInt	
2654	Gateway	0.0.0.0	42715	167/129	4A9B	19099	UInt, 1=1	UInt	
			42716	167/130	4A9C	19100	UInt, 1=1	UInt	
			42717	167/131	4A9D	19101	UInt, 1=1	UInt	
			42718	167/132	4A9E	19102	UInt, 1=1	UInt	
2655	DHCP	Off	42719	167/133	4A9F	19103	UInt	UInt	
2656	FTP Server	Off	42720	167/134	4AA0	19104	UInt	UInt	
2657	WEB Server	Off	42721	167/135	4AA1	19105	UInt	UInt	
266	Fieldbus Signals [266]								
2661	FB S1/Wr1	0	42801	167/215	4AF1	19185	UInt, 1=1	UInt	

Menu Parameters		Default settings	Modbus Instance/ Device Net No.	Profibus slot/index	EtherCAT index (HEX)	Profinet index	Fieldbus format	Modbus format	Notes
2662	FB S2/Wr2	0	42802	167/216	4AF2	19186	UInt, 1=1	UInt	
2663	FB S3/Wr3	0	42803	167/217	4AF3	19187	UInt, 1=1	UInt	
2664	FB S4/Wr4	0	42804	167/218	4AF4	19188	UInt, 1=1	UInt	
2665	FB S5/Wr5	0	42805	167/219	4AF5	19189	UInt, 1=1	UInt	
2666	FB S6/Wr6	0	42806	167/220	4AF6	19190	UInt, 1=1	UInt	
2667	FB S7/Wr7	0	42807	167/221	4AF7	19191	UInt, 1=1	UInt	
2668	FB S8/Wr8	0	42808	167/222	4AF8	19192	UInt, 1=1	UInt	
2669	FB S9/Rd1	0	42809	167/223	4AF9	19193	UInt, 1=1	UInt	
266A	FB S10/Rd2	0	42810	167/224	4AFA	19194	UInt, 1=1	UInt	
266B	FB S11/Rd3	0	42811	167/225	4AFB	19195	UInt, 1=1	UInt	
266C	FB S12/Rd4	0	42812	167/226	4AFC	19196	UInt, 1=1	UInt	
266D	FB S13/Rd5	0	42813	167/227	4AFD	19197	UInt, 1=1	UInt	
266E	FB S14/Rd6	0	42814	167/228	4AFE	19198	UInt, 1=1	UInt	
266F	FB S15/Rd7	0	42815	167/229	4AFF	19199	UInt, 1=1	UInt	
266G	FB S16/Rd8	0	42816	167/230	4B00	19200	UInt, 1=1	UInt	
269	FB Status								
270	Wireless [270]								
271	WirelessMode	Off	40200	157/164	40C8	16584	UInt	UInt	
272	WiFi Options [272]								
2721	WiFi Mode	AccessPoint	40201	157/165	40C9	16585	UInt	UInt	
2722	Channel	5	40202	157/166	40CA	16586	UInt, 1=1	UInt	
2723	Encryption	WPA-2	40203	157/167	40CB	16587	UInt	UInt	
2724	DHCP	Static	40204	157/168	40CC	16588	UInt	UInt	
2725	SSID	Emotron_<5 random digits>	40215	157/179	40D7	16699	UInt	UInt	
2726	Password	12345678	40235	157/199	40EB	16619	UInt	UInt	
2727	IP Address	192.168.1.1	40255	157/219	40FF	16639	UInt, 1=1	UInt	
			40256	157/220	4100	16640	UInt, 1=1	UInt	
			40257	157/221	4101	16641	UInt, 1=1	UInt	
			40258	157/222	4102	16642	UInt, 1=1	UInt	
2728	Subnet Mask	255.255.255.0	40259	157/223	4103	16643	UInt, 1=1	UInt	
			40260	157/224	4104	16644	UInt, 1=1	UInt	
			40261	157/225	4105	16645	UInt, 1=1	UInt	
			40262	157/226	4106	16646	UInt, 1=1	UInt	
2729	Gateway	192.168.1.1	40263	157/227	4107	16647	UInt, 1=1	UInt	
			40264	157/228	4108	16648	UInt, 1=1	UInt	
			40265	157/229	4109	16649	UInt, 1=1	UInt	
			40266	157/230	410A	16650	UInt, 1=1	UInt	
272A	WiFi Status	OK	30054	117/218	2036	54	UInt	UInt	

Menu Parameters		Default settings	Modbus Instance/ Device Net No.	Profibus slot/index	EtherCAT index (HEX)	Profinet index	Fieldbus format	Modbus format	Notes
273	Bluetooth (BLE) options [273]								
2731	BluetoothID	0.0.0.0	42620	167/34	4A3C	19004	UInt, 1=1	UInt	
2732	Paring Key	123456	40267	157/231	410B	16651	UInt, 1=1	UInt	
274	Security [274]								
2741	Sec. Mode	Open	40273	157/237	4111	16657	UInt	UInt	
2742	Password	Empty string							Not accessible via communication. Edit using PPU.
300	Process and Application Parameters [300]								
310	Set/View ref		42991	168/150	4BAF	19375	Long, 1=0.001	Elnt	
320	Process Settings [320]								
321	Proc Source	Speed	43302	169/206	4CE6	19686	UInt	UInt	
322	Proc Unit	Off	43303	169/207	4CE7	19687	UInt	UInt	
323	User Unit	0	43304	169/208	4CE8	19688	UInt	UInt	
			43305	169/209	4CE9	19689	UInt	UInt	
			43306	169/210	4CEA	19690	UInt	UInt	
			43307	169/211	4CEB	19691	UInt	UInt	
			43308	169/212	4CEC	19692	UInt	UInt	
			43309	169/213	4CED	19693	UInt	UInt	
324	Process Min	0	43310	169/214	4CEE	19694	Long, 1=0.001	Elnt	
325	Process Max	0	43311	169/215	4CEF	19695	Long, 1=0.001	Elnt	
326	Ratio	Linnear	43312	169/216	4CF0	19696	UInt	UInt	
327	F(Val) PrMin	Min	43313	169/217	4CF1	19697	Long, 1=1	Elnt	
328	F(Val) PrMax	Max	43314	169/218	4CF2	19698	Long, 1=1	Elnt	
330	Start/Stop settings [330]								
331	Acc Time	10s	43101	169/5	4C1D	19485	Long, 1=0.01s	Elnt	
332	Dec Time	10s	43102	169/6	4C1E	19486	Long, 1=0.01s	Elnt	
333	Acc MotPot	16s	43103	169/7	4C1F	19487	Long, 1=0.01s	Elnt	
334	Dec MotPot	16s	43104	169/8	4C20	19488	Long, 1=0.01s	Elnt	
335	Acc<Min Spd	10s	43105	169/9	4C21	19489	Long, 1=0.01s	Elnt	
336	Dec<Min Spd	10s	43106	169/10	4C22	19490	Long, 1=0.01s	Elnt	
337	Acc Rmp	Linear	43107	169/11	4C23	19491	UInt	UInt	
338	Dec Rmp	Linear	43108	169/12	4C24	19492	UInt	UInt	
339	Start Mode	Normal DC	43109	169/13	4C25	19493	UInt	UInt	
33A	Spinstart	Off	43110	169/14	4C26	19494	UInt	UInt	
33B	Stop Mode	Decel	43111	169/15	4C27	19495	UInt	UInt	
33C	Brk Release	0s	43112	169/16	4C28	19496	Long, 1=0.01s	Elnt	

Menu Parameters		Default settings	Modbus Instance/ Device Net No.	Profibus slot/index	EtherCAT index (HEX)	Profinet index	Fieldbus format	Modbus format	Notes
33D	Release Spd	0rpm	43113	169/17	4C29	19497	Int, 1=1rpm	Int	
33E	Brk Engage	0s	43114	169/18	4C2A	19498	Long, 1=0.01s	Elnt	
33F	Brk Wait	0s	43115	169/19	4C2B	19499	Long, 1=0.01s	Elnt	
33G	Vector Brake	Off	43116	169/20	4C2C	19500	UInt	UInt	
33H	Brk Fault	1s	43117	169/21	4C2D	19501	Long, 1=0.01s	Elnt	
33I	Release Trq	0%	43118	169/22	4C2E	19502	Long, 1=1%	Elnt	
33J	DC Hold [33J]								
33J1	DC Hold	Off	43148	169/52	4C4C	19532	UInt	UInt	
33J2	DC Hold Spd	10rpm	43149	169/53	4C4D	19533	UInt, 1=1rpm	UInt	
33J3	DC Hold Cur	30%	43150	169/54	4C4E	19534	UInt, 1=1%	UInt	
33K	Start Vector	Normal (U)	43119	169/23	4C2F	19503	UInt	UInt	
340	Speed [340]								
341	Min Speed	0rpm	43121	169/25	4C31	19505	Int, 1=1rpm	Int	
342	Stp<MinSpd	Off	43122	169/26	4C32	19506	Long, 1=0.01s	Elnt	
343	Max Speed	Sync speed	43123	169/27	4C33	19507	Int, 1=1rpm	Int	
344	SkipSpd 1 Lo	0rpm	43124	169/28	4C34	19508	Int, 1=1rpm	Int	
345	SkipSpd 1 Hi	0rpm	43125	169/29	4C35	19509	Int, 1=1rpm	Int	
346	SkipSpd 2 Lo	0rpm	43126	169/30	4C36	19510	Int, 1=1rpm	Int	
347	SkipSpd 2 Hi	0rpm	43127	169/31	4C37	19511	Int, 1=1rpm	Int	
348	Jog Speed	50rpm	43128	169/32	4C38	19512	Int, 1=1rpm	Int	
349	Droop Speed	0%	43120	169/24	4C30	19504	Long, 1=0.01%	Elnt	
34A	OverSpdTrip	110%	43129	169/33	4C39	19513	UInt, 1=1%	UInt	
350	Torques [350]								
351	Max Torque	120%	43141	169/45	4C45	19525	Long, 1=1%	Elnt	
352	IxR Comp	Off	43142	169/46	4C46	19526	UInt	UInt	
353	IxR CompUsr	0%	43143	169/47	4C47	19527	Long, 1=0.1%	Elnt	
354	Flux optim	Off	43144	169/48	4C48	19528	UInt	UInt	
355	Max Power	Off	43145	169/49	4C49	19529	Long, 1=1%	Elnt	
356	Torque Ramp	Off	43146	169/50	4C4A	19530	UInt, 1=0.01s	UInt	
357	Torque Limitation Trip Time	Off	43147	169/51	4C4B	19531	UInt, 1=0.1s	UInt	
360	Preset References [360]								
361	Motor Pot	Non volatile	43131	169/35	4C3B	19515	UInt	UInt	
362	Preset Ref 1	0	43132	169/36	4C3C	19516	Long, 1=0.001	Elnt	
363	Preset Ref 2	250	43133	169/37	4C3D	19517	Long, 1=0.001	Elnt	
364	Preset Ref 3	500	43134	169/38	4C3E	19518	Long, 1=0.001	Elnt	
365	Preset Ref 4	750	43135	169/39	4C3F	19519	Long, 1=0.001	Elnt	
366	Preset Ref 5	1000	43136	169/40	4C40	19520	Long, 1=0.001	Elnt	

Menu Parameters		Default settings	Modbus Instance/ Device Net No.	Profibus slot/index	EtherCAT index (HEX)	Profinet index	Fieldbus format	Modbus format	Notes
367	Preset Ref 6	1250	43137	169/41	4C41	19521	Long, 1=0.001	Elnt	
368	Preset Ref 7	1500	43138	169/42	4C42	19522	Long, 1=0.001	Elnt	
369	Key Ref Mode	MotPot	43139	169/43	4C43	19523	Uln	Uln	
370	PI Speed Control [370]								
371	Spd PI Auto	Off	43151	169/55	4C4F	19535	Uln	Uln	
372	Spd P Gain	5	43152	169/56	4C50	19536	Long, 1=0.1	Elnt	
373	Spd I Time	0,14 s	43153	169/57	4C51	19537	Long, 1=0.01s	Elnt	
380	PID Process Control [380]								
381	PID Control	Off	43154	169/58	4C52	19538	Uln	Uln	
383	PID P Gain	1	43156	169/60	4C54	19540	Long, 1=0.1	Elnt	
384	PID I Time	1s	43157	169/61	4C55	19541	Long, 1=0.01s	Elnt	
385	PID D Time	0s	43158	169/62	4C56	19542	Long, 1=0.01s	Elnt	
386	PID<MinSpd	Off	43371	170/20	4D2B	19755	Long, 1=0.01s	Elnt	
387	PID Act Marg	0	43372	170/21	4D2C	19756	Long, 1=0.001	Elnt	
388	PID Stdy Tst	Off	43373	170/22	4D2D	19757	Long, 1=0.01s	Elnt	
389	PID Stdy Mar	0	43374	170/23	4D2E	19758	Long, 1=0.001	Elnt	
390	EmoDedic Pump								
391	Pump/Fan Ctl								
3911	Pump enable	Off	43161	169/65	4C59	19545	Uln	Uln	
3912	No of Drives	2	43162	169/66	4C5A	19546	Uln, 1=1	Uln	
3913	Select Drive	Sequence	43163	169/67	4C5B	19547	Uln	Uln	
3914	Change Cond	Both	43164	169/68	4C5C	19548	Uln	Uln	
3915	Change Timer	50h	43165	169/69	4C5D	19549	Uln, 1=1h	Uln	
3916	Drives on Ch	0	43166	169/70	4C5E	19550	Uln, 1=1	Uln	
3917	Upper Band	10%	43167	169/71	4C5F	19551	Long, 1=1%	Elnt	
3918	Lower Band	10%	43168	169/72	4C60	19552	Long, 1=1%	Elnt	
3919	Start Delay	0s	43169	169/73	4C61	19553	Long, 1=1s	Elnt	
391A	Stop Delay	0s	43170	169/74	4C62	19554	Long, 1=1s	Elnt	
391B	Upp Band Lim	0%	43171	169/75	4C63	19555	Long, 1=1%	Elnt	
391C	Low Band Lim	0%	43172	169/76	4C64	19556	Long, 1=1%	Elnt	
391D	Settle Start	0%	43173	169/77	4C65	19557	Long, 1=1s	Elnt	
391E	TransS Start	60%	43174	169/78	4C66	19558	Long, 1=1%	Elnt	
391F	Settle Stop	0s	43175	169/79	4C67	19559	Long, 1=1s	Elnt	
391G	TransS Stop	60%	43176	169/80	4C68	19560	Long, 1=1%	Elnt	
391H	Run Time 1		31051	121/195	241B	1051	Long, 1=1h	Elnt	
			31052	121/196	241C	1052	Long, 1=1m	Elnt	
			31053	121/197	241D	1053	Long, 1=1s	Elnt	
391H1	Rst Run Tm1	No	38	0/37	2026	38	Uln	Uln	

Menu Parameters		Default settings	Modbus Instance/ Device Net No.	Profibus slot/index	EtherCAT index (HEX)	Profinet index	Fieldbus format	Modbus format	Notes
391I	Run Time 2		31054	121/198	241E	1054	Long, 1=1h	Elnt	
			31055	121/199	241F	1055	Long, 1=1m	Elnt	
			31056	121/200	2420	1056	Long, 1=1s	Elnt	
391I1	Rst Run Tm2	No	39	0/38	2027	39	UInt	UInt	
391J	Run Time 3		31057	121/201	2421	1057	Long, 1=1h	Elnt	
			31058	121/202	2422	1058	Long, 1=1m	Elnt	
			31059	121/203	2423	1059	Long, 1=1s	Elnt	
391J1	Rst Run Tm3	No	40	0/39	2028	40	UInt	UInt	
391K	Run Time 4		31060	121/204	2424	1060	Long, 1=1h	Elnt	
			31061	121/205	2425	1061	Long, 1=1m	Elnt	
			31062	121/206	2426	1062	Long, 1=1s	Elnt	
391K1	Rst Run Tm4	No	41	0/40	2029	41	UInt	UInt	
391L	Run Time 5		31063	121/207	2427	1063	Long, 1=1h	Elnt	
			31064	121/208	2428	1064	Long, 1=1m	Elnt	
			31065	121/209	2429	1065	Long, 1=1s	Elnt	
391L1	Rst Run Tm5	No	42	0/41	202A	42	UInt	UInt	
391M	Run Time 6		31066	121/210	242A	1066	Long, 1=1h	Elnt	
			31067	121/211	242B	1067	Long, 1=1m	Elnt	
			31068	121/212	242C	1068	Long, 1=1s	Elnt	
391M1	Rst Run Tm6	No	43	0/42	202B	43	UInt	UInt	
391N	Pump 123456		31069	121/213	242D	1069	UInt, 1=1	UInt	
391P	No of Backup	0	43177	169/81	4C69	19561	UInt, 1=1	UInt	
391Q	MstChNoRamp	Off	43178	169/82	4C6A	19562	UInt	UInt	
392	PumpCleaning								
3921	PC Enable	Off	43701	171/95	4E75	20085	UInt	UInt	
3922	PC Allow	On	43702	171/96	4E76	20086	UInt	UInt	
392A	PC Trigger								
392A1	Force	Off	42898	168/57	4B52	19282	UInt	UInt	
392A2	EachStart	Off	43703	171/97	4E77	20087	UInt	UInt	
392A3	LoadMonMarg	Off	43704	171/98	4E78	20088	Long, 1=1%	Elnt	
392A4	LMTrigDelay	0.1 s	43705	171/99	4E79	20089	Long, 1=0.1s	Elnt	
392A5	RunTime	Off	43706	171/100	4E7A	20090	UInt, 1=1h	UInt	
392A6	Interval	Off	43707	171/101	4E7B	20091	UInt, 1=1weeks	UInt	
392A7	Weekday	-----	43708	171/102	4E7C	20092	Long, 1=1	Elnt	
392A8	StartTime	00:00:00	43709	171/103	4E7D	20093	Long, 1=1h	Elnt	
			43710	171/104	4E7E	20094	Long, 1=1m	Elnt	
			43711	171/105	4E7F	20095	Long, 1=1s	Elnt	

Menu Parameters		Default settings	Modbus Instance/ Device Net No.	Profibus slot/index	EtherCAT index (HEX)	Profinet index	Fieldbus format	Modbus format	Notes
392A9	StartDate	2000-00-00	43712	171/106	4E80	20096	Long, 1=1y	Elnt	
			43713	171/107	4E81	20097	Long, 1=1m	Elnt	
			43714	171/108	4E82	20098	Long, 1=1d	Elnt	
392B	PC Phase 1								
392B1	Ph1 Time	10 s	43715	171/109	4E83	20099	UInt, 1=1s	UInt	
392B2	Ph1 RefSpd	-100 %	43716	171/110	4E84	20100	Int, 1=1%	Int	
392B3	Ph1 AccTime	Off	43717	171/111	4E85	20101	Long, 1=0.1s	Elnt	
392B4	Ph 1DecTime	Off	43718	171/112	4E86	20102	Long, 1=0.1s	Elnt	
392C	PC Phase 2								
392C1	Ph2 Time	10 s	43719	171/113	4E87	20103	UInt, 1=1s	UInt	
392C2	Ph2 RefSpd	100 %	43720	171/114	4E88	20104	Int, 1=1%	Int	
392C3	Ph2 AccTime	Off	43721	171/115	4E89	20105	Long, 1=0.1s	Elnt	
392C4	Ph2 DecTime	Off	43722	171/116	4E8A	20106	Long, 1=0.1s	Elnt	
392D	PC Phase 3								
392D1	Ph3 Time	Off	43723	171/117	4E8B	20107	UInt, 1=1s	UInt	
392D2	Ph3 RefSpd	50 %	43724	171/118	4E8C	20108	Int, 1=1%	Int	
392D3	Ph3 AccTime	Off	43725	171/119	4E8D	20109	Long, 1=0.1s	Elnt	
392D4	Ph3 DecTime	Off	43726	171/120	4E8E	20110	Long, 1=0.1s	Elnt	
392E	PC MaxAttmpt	8	43727	171/121	4E8F	20111	UInt, 1=1	UInt	
392F	PC Status								
392F1	State	Off	31075	121/219	2433	1075	UInt	UInt	
392F2	AttmptCnt		31076	121/220	2434	1076	UInt, 1=1	UInt	
392F3	ResetCnt	No	12	0/11	200C	12	UInt	UInt	
392F4	TotCnt		31077	121/221	2435	1077	UInt, 1=1	UInt	
392F5	TotCntSince		31078	121/222	2436	1078	UInt, 1=1h	UInt	
392F6	TotCntReset	No	13	0/12	200D	13	UInt	UInt	
3A0	Crane Option [3A0]								
3A1	Crane enable	Off	43181	169/85	4C6D	19565	UInt	UInt	
3A2	Control	4-Speeds	43182	169/86	4C6E	19566	UInt	UInt	
3A3	Crane Relay1	No Trip	43183	169/87	4C6F	19567	UInt	UInt	
3A4	Crane Relay2	Brake	43184	169/88	4C70	19568	UInt	UInt	
3A5	PreLimSwSpd	100rpm	43185	169/89	4C71	19569	Int, 1=1rpm	Int	
3A6	CrawlSpd H/R	150rpm	43189	169/93	4C75	19573	Int, 1=1rpm	Int	
3A7	CrawlSpd L/L	150rpm	43190	169/94	4C76	19574	Int, 1=1rpm	Int	
3A8	Speed 2	600rpm	43186	169/90	4C72	19570	Int, 1=1rpm	Int	
3A9	Speed 3	1000rpm	43187	169/91	4C73	19571	Int, 1=1rpm	Int	
3AA	Speed 4	1500rpm	43188	169/92	4C74	19572	Int, 1=1rpm	Int	
3AB	Dev Bandwidt	100rpm	43191	169/95	4C77	19575	Int, 1=1rpm	Int	

Menu Parameters		Default settings	Modbus Instance/ Device Net No.	Profibus slot/index	EtherCAT index (HEX)	Profinet index	Fieldbus format	Modbus format	Notes
3AC	Dev Time	0.10s	43192	169/96	4C78	19576	Long, 1=0.001s	Elnt	
3AD	LAFS Load	Off	43193	169/97	4C79	19577	Long, 1=1%	Elnt	
3AG	Crane N Func	Zero Pos	43194	169/98	4C7A	19578	Ulnr	Ulnr	
400	Load Monitor and Process Protection [400]								
410	Load Monitor [410]								
411	Alarm Select	Off	43321	169/225	4CF9	19705	Ulnr	Ulnr	
412	Alarm trip	Off	43322	169/226	4CFA	19706	Ulnr	Ulnr	
413	Ramp Alarm	Off	43323	169/227	4CFB	19707	Ulnr	Ulnr	
414	Start Delay	2s	43324	169/228	4CFC	19708	Long, 1=1s	Elnt	
415	Load Type	Basic	43325	169/229	4CFD	19709	Ulnr	Ulnr	
416	Max Alarm [416]								
4161	MaxAlarmMar	15%	43326	169/230	4CFE	19710	Long, 1=1%	Elnt	
4162	MaxAlarmDel	0,1s	43330	169/234	4D02	19714	Long, 1=0.1s	Elnt	
417	Max Pre Alarm [417]								
4171	MaxPreAlMar	10%	43327	169/231	4CFF	19711	Long, 1=1%	Elnt	
4172	MaxAlarmDel	0.1s	43331	169/235	4D03	19715	Long, 1=0.1s	Elnt	
418	Min Pre Alarm [418]								
4181	MinPreAlMar	10%	43328	169/232	4D00	19712	Long, 1=1%	Elnt	
4182	MinPreAlDel	0.1s	43332	169/236	4D04	19716	Long, 1=0.1s	Elnt	
419	Min Alarm [419]								
4191	MinAlarmMar	15%	43329	169/233	4D01	19713	Long, 1=1%	Elnt	
4192	MinAlarmDel	0.1s	43333	169/237	4D05	19717	Long, 1=0.1s	Elnt	
41A	Autoset Alrm	No	43334	169/238	4D06	19718	Ulnr	Ulnr	
41B	Normal Load	100%	43335	169/239	4D07	19719	Long, 1=1%	Elnt	
41C	Load Curve [41C]								
41C1	Load Curve1	100%	43336	169/240	4D08	19720	Long, 1=1%	Elnt	
			43337	169/241	4D09	19721	Int, 1=1rpm	Int	
41C2	Load Curve 2	100%	43338	169/242	4D0A	19722	Long, 1=1%	Elnt	
			43339	169/243	4D0B	19723	Int, 1=1rpm	Int	
41C3	Load Curve 3	100%	43340	169/244	4D0C	19724	Long, 1=1%	Elnt	
			43341	169/245	4D0D	19725	Int, 1=1rpm	Int	
41C4	Load Curve 4	100%	43342	169/246	4D0E	19726	Long, 1=1%	Elnt	
			43343	169/247	4D0F	19727	Int, 1=1rpm	Int	

Menu Parameters		Default settings	Modbus Instance/ Device Net No.	Profibus slot/index	EtherCAT index (HEX)	Profinet index	Fieldbus format	Modbus format	Notes
41C5	Load Curve 5	100%	43344	169/248	4D10	19728	Long, 1=1%	EInt	
			43345	169/249	4D11	19729	Int, 1=1rpm	Int	
41C6	Load Curve 6	100%	43346	169/250	4D12	19730	Long, 1=1%	EInt	
			43347	169/251	4D13	19731	Int, 1=1rpm	Int	
41C7	Load Curve 7	100%	43348	169/252	4D14	19732	Long, 1=1%	EInt	
			43349	169/253	4D15	19733	Int, 1=1rpm	Int	
41C8	Load Curve 8	100%	43350	169/254	4D16	19734	Long, 1=1%	EInt	
			43351	170/0	4D17	19735	Int, 1=1rpm	Int	
41C9	Load Curve 9	100%	43352	170/1	4D18	19736	Long, 1=1%	EInt	
			43353	170/2	4D19	19737	Int, 1=1rpm	Int	
41D	MinAbsMarg	3%	43354	170/3	4D1A	19738	Long, 1=1%	EInt	
420	Process Protection [420]								
421	Low Voltage Override								
4211	LVO Control	On	43361	170/10	4D21	19745	UInt	UInt	
4212	LVO Sleep Time	Off	43365	170/14	4D25	19749	UInt, 1=1s	UInt	
422	Rotor locked	Off	43362	170/11	4D22	19746	UInt	UInt	
423	Motor Lost	Off	43363	170/12	4D23	19747	UInt	UInt	
424	OverVolt Ctl	On	43364	170/13	4D24	19748	UInt	UInt	
430	Trip Text								
431	ExtTrip1Text	Ext Trip 1	42457	166/126	4999	18841	UInt	UInt	
			42458	166/127	499A	18842	UInt	UInt	
			42459	166/128	499B	18843	UInt	UInt	
			42460	166/129	499C	18844	UInt	UInt	
			42461	166/130	499D	18845	UInt	UInt	
			42462	166/131	499E	18846	UInt	UInt	
			42463	166/132	499F	18847	UInt	UInt	
			42464	166/133	49A0	18848	UInt	UInt	
			42465	166/134	49A1	18849	UInt	UInt	
			42466	166/135	49A2	18850	UInt	UInt	
			42467	166/136	49A3	18851	UInt	UInt	
42468	166/137	49A4	18852	UInt	UInt				

Menu Parameters		Default settings	Modbus Instance/ Device Net No.	Profibus slot/index	EtherCAT index (HEX)	Profinet index	Fieldbus format	Modbus format	Notes
432	ExtTrip2Text	Ext Trip 2	42469	166/138	49A5	18853	UInt	UInt	
			42470	166/139	49A6	18854	UInt	UInt	
			42471	166/140	49A7	18855	UInt	UInt	
			42472	166/141	49A8	18856	UInt	UInt	
			42473	166/142	49A9	18857	UInt	UInt	
			42474	166/143	49AA	18858	UInt	UInt	
			42475	166/144	49AB	18859	UInt	UInt	
			42476	166/145	49AC	18860	UInt	UInt	
			42477	166/146	49AD	18861	UInt	UInt	
			42478	166/147	49AE	18862	UInt	UInt	
			42479	166/148	49AF	18863	UInt	UInt	
433	ExtTrip3Text	Ext Trip 3	42480	166/149	49B0	18864	UInt	UInt	
			42481	166/150	49B1	18865	UInt	UInt	
			42482	166/151	49B2	18866	UInt	UInt	
			42483	166/152	49B3	18867	UInt	UInt	
			42484	166/153	49B4	18868	UInt	UInt	
			42485	166/154	49B5	18869	UInt	UInt	
			42486	166/155	49B6	18870	UInt	UInt	
			42487	166/156	49B7	18871	UInt	UInt	
			42488	166/157	49B8	18872	UInt	UInt	
			42489	166/158	49B9	18873	UInt	UInt	
			42490	166/159	49BA	18874	UInt	UInt	
434	ExtTrip4Text	Ext Trip 4	42491	166/160	49BB	18875	UInt	UInt	
			42492	166/161	49BC	18876	UInt	UInt	
			42493	166/162	49BD	18877	UInt	UInt	
			42494	166/163	49BE	18878	UInt	UInt	
			42495	166/164	49BF	18879	UInt	UInt	
			42496	166/165	49C0	18880	UInt	UInt	
			42497	166/166	49C1	18881	UInt	UInt	
			42498	166/167	49C2	18882	UInt	UInt	
			42499	166/168	49C3	18883	UInt	UInt	
			42500	166/169	49C4	18884	UInt	UInt	
			42501	166/170	49C5	18885	UInt	UInt	
500	I/Os and Virtual Connections [500]		42502	166/171	49C6	18886	UInt	UInt	
			42503	166/172	49C7	18887	UInt	UInt	
			42504	166/173	49C8	18888	UInt	UInt	

Menu Parameters		Default settings	Modbus Instance/ Device Net No.	Profibus slot/index	EtherCAT index (HEX)	Profinet index	Fieldbus format	Modbus format	Notes
510	Analogue Inputs [510]								
511	AnIn1 Fc	Process Ref	43201	169/105	4C81	19585	UInt	UInt	
512	AnIn1 Setup	4-20mA	43202	169/106	4C82	19586	UInt	UInt	
513	AnIn1 Advan								
5131	AnIn1 Min	4mA	43203	169/107	4C83	19587	Long, 1=0.01	EInt	
5132	AnIn1 Max	20mA	43204	169/108	4C84	19588	Long, 1=0.01	EInt	
5133	AnIn1 Bipol	20mA	43205	169/109	4C85	19589	Long, 1=0.01	EInt	
5134	AnIn1 FcMin	Min	43206	169/110	4C86	19590	UInt	UInt	
5135	AnIn1 VaMin	0	43541	170/190	4DD5	19925	Long, 1=0.001	EInt	
5136	AnIn1 FcMax	Max	43207	169/111	4C87	19591	UInt	UInt	
5137	AnIn1 VaMax	0	43551	170/200	4DDF	19935	Long, 1=0.001	EInt	
5138	AnIn1 Oper	Add +	43208	169/112	4C88	19592	UInt	UInt	
5139	AnIn1 Filt	0.1s	43209	169/113	4C89	19593	Long, 1=0.001s	EInt	
513A	AnIn1 Enabl	On	43210	169/114	4C8A	19594	UInt	UInt	
514	AnIn2 Fc	Off	43211	169/115	4C8B	19595	UInt	UInt	
515	AnIn2 Setup	4-20mA	43212	169/116	4C8C	19596	UInt	UInt	
516	AnIn2 Advan								
5161	AnIn2 Min	4mA	43213	169/117	4C8D	19597	Long, 1=0.01	EInt	
5162	AnIn2 Max	20mA	43214	169/118	4C8E	19598	Long, 1=0.01	EInt	
5163	AnIn2 Bipol	20mA	43215	169/119	4C8F	19599	Long, 1=0.01	EInt	
5164	AnIn2 FcMin	Min	43216	169/120	4C90	19600	UInt	UInt	
5165	AnIn2 VaMin	0	43542	170/191	4DD6	19926	Long, 1=0.001	EInt	
5166	AnIn2 FcMax	Max	43217	169/121	4C91	19601	UInt	UInt	
5167	AnIn2 VaMax	0	43552	170/201	4DE0	19936	Long, 1=0.001	EInt	
5168	AnIn2 Oper	Add +	43218	169/122	4C92	19602	UInt	UInt	
5169	AnIn2 Filt	0.1s	43219	169/123	4C93	19603	Long, 1=0.001s	EInt	
516A	AnIn2 Enabl	On	43220	169/124	4C94	19604	UInt	UInt	
517	AnIn3 Fc	Off	43221	169/125	4C95	19605	UInt	UInt	
518	AnIn3 Setup	4-20mA	43222	169/126	4C96	19606	UInt	UInt	
519	AnIn3 Advan								
5191	AnIn3 Min	4mA	43223	169/127	4C97	19607	Long, 1=0.01	EInt	
5192	AnIn3 Max	20mA	43224	169/128	4C98	19608	Long, 1=0.01	EInt	
5193	AnIn3 Bipol	20mA	43225	169/129	4C99	19609	Long, 1=0.01	EInt	
5194	AnIn3 FcMin	Min	43226	169/130	4C9A	19610	UInt	UInt	
5195	AnIn3 VaMin	0	43543	170/192	4DD7	19927	Long, 1=0.001	EInt	
5196	AnIn3 FcMax	Max	43227	169/131	4C9B	19611	UInt	UInt	
5197	AnIn3 VaMax	0	43553	170/202	4DE1	19937	Long, 1=0.001	EInt	
5198	AnIn3 Oper	Add +	43228	169/132	4C9C	19612	UInt	UInt	

Menu Parameters		Default settings	Modbus Instance/ Device Net No.	Profibus slot/index	EtherCAT index (HEX)	Profinet index	Fieldbus format	Modbus format	Notes
5199	AnIn3 Filt	0,1s	43229	169/133	4C9D	19613	Long, 1=0.001s	Elnt	
519A	AnIn3 Enabl	On	43230	169/134	4C9E	19614	Uln	Uln	
51A	AnIn4 Fc	Off	43231	169/135	4C9F	19615	Uln	Uln	
51B	AnIn4 Setup	4-20mA	43232	169/136	4CA0	19616	Uln	Uln	
51C	AnIn4 Advan								
51C1	AnIn4 Min	4mA	43233	169/137	4CA1	19617	Long, 1=0.01	Elnt	
51C2	AnIn4 Max	20mA	43234	169/138	4CA2	19618	Long, 1=0.01	Elnt	
51C3	AnIn4 Bipol	20mA	43235	169/139	4CA3	19619	Long, 1=0.01	Elnt	
51C4	AnIn4 FcMin	Min	43236	169/140	4CA4	19620	Uln	Uln	
51C5	AnIn4 VaMin	0	43544	170/193	4DD8	19928	Long, 1=0.001	Elnt	
51C6	AnIn4 FcMax	Max	43237	169/141	4CA5	19621	Uln	Uln	
51C7	AnIn4 VaMax	0	43554	170/203	4DE2	19938	Long, 1=0.001	Elnt	
51C8	AnIn4 Oper	Add +	43238	169/142	4CA6	19622	Uln	Uln	
51C9	AnIn4 Filt	0,1s	43239	169/143	4CA7	19623	Long, 1=0.001s	Elnt	
51CA	AnIn4 Enabl	On	43240	169/144	4CA8	19624	Uln	Uln	
51D	AnIn Fault								
51D1	AnIn FitMode	Off	42859	168/18	4B2B	19243	Uln	Uln	
51D2	AnIn FitRef	0 %	42860	168/19	4B2C	19244	Uln, 1=1%	Uln	
51D3	AnIn Reset	No	14	0/13	200E	14	Uln	Uln	
51E	Analog Input Resolution								
51E1	Analog Input Resolution on the Control Panel	1%	43197	169/101	4C7D	19581	Uln	Uln	
51E2	Analog Input Resolution in Communication	1%	43198	169/102	4C7E	19582	Uln	Uln	
520	Digital Inputs [520]								
521	DigIn 1	RunL	43241	169/145	4CA9	19625	Uln	Uln	
522	DigIn 2	RunR	43242	169/146	4CAA	19626	Uln	Uln	
523	DigIn 3	Off	43243	169/147	4CAB	19627	Uln	Uln	
524	DigIn 4	Off	43244	169/148	4CAC	19628	Uln	Uln	
525	DigIn 5	Off	43245	169/149	4CAD	19629	Uln	Uln	
526	DigIn 6	Off	43246	169/150	4CAE	19630	Uln	Uln	
527	DigIn 7	Off	43247	169/151	4CAF	19631	Uln	Uln	
528	DigIn 8	Reset	43248	169/152	4CBO	19632	Uln	Uln	
529	B1 DigIn 1	Off	43501	170/150	4DAD	19885	Uln	Uln	
52A	B1 DigIn 2	Off	43502	170/151	4DAE	19886	Uln	Uln	
52B	B1 DigIn 3	Off	43503	170/152	4DAF	19887	Uln	Uln	
52C	B2 DigIn 1	Off	43504	170/153	4DB0	19888	Uln	Uln	

Menu Parameters		Default settings	Modbus Instance/ Device Net No.	Profibus slot/index	EtherCAT index (HEX)	Profinet index	Fieldbus format	Modbus format	Notes
52D	B2 DigIn 2	Off	43505	170/154	4DB1	19889	UInt	UInt	
52E	B2 DigIn 3	Off	43506	170/155	4DB2	19890	UInt	UInt	
52F	B3 DigIn 1	Off	43507	170/156	4DB3	19891	UInt	UInt	
52G	B3 DigIn 2	Off	43508	170/157	4DB4	19892	UInt	UInt	
52H	B3 DigIn 3	Off	43509	170/158	4DB5	19893	UInt	UInt	
530	Analogue Outputs [530]								
531	AnOut1 Fc	Speed	43251	169/155	4CB3	19635	UInt	UInt	
532	AnOut1 Setup	4-20mA	43252	169/156	4CB4	19636	UInt	UInt	
533	AnOut 1 Advan								
5331	AnOut 1 Min	4mA	43253	169/157	4CB5	19637	Long, 1=0.01	Elnt	
5332	AnOut 1 Max	20mA	43254	169/158	4CB6	19638	Long, 1=0.01	Elnt	
5333	AnOut1Bipol	20mA	43255	169/159	4CB7	19639	Long, 1=0.01	Elnt	
5334	AnOut1FCMin	Min	43256	169/160	4CB8	19640	UInt	UInt	
5335	AnOut1VaMin	0	43545	170/194	4DD9	19929	Long, 1=0.001	Elnt	
5336	AnOut1FCMax	Max	43257	169/161	4CB9	19641	UInt	UInt	
5337	AnOut1VaMax	0	43555	170/204	4DE3	19939	Long, 1=0.001	Elnt	
534	AnOut2 Fc	Torque	43261	169/165	4CBD	19645	UInt	UInt	
535	AnOut2 Setup	4-20mA	43262	169/166	4CBE	19646	UInt	UInt	
536	AnOut2 Advan								
5361	AnOut2 Min	4mA	43263	169/167	4CBF	19647	Long, 1=0.01	Elnt	
5362	AnOut2 Max	20mA	43264	169/168	4CC0	19648	Long, 1=0.01	Elnt	
5363	AnOut2Bipol	20mA	43265	169/169	4CC1	19649	Long, 1=0.01	Elnt	
5364	AnOut2FcMin	Min	43266	169/170	4CC2	19650	UInt	UInt	
5365	AnOut2VaMin	0	43546	170/195	4DDA	19930	Long, 1=0.001	Elnt	
5366	AnOut2FcMax	Max	43267	169/171	4CC3	19651	UInt	UInt	
5367	AnOut2VaMax	0	43556	170/205	4DE4	19940	Long, 1=0.001	Elnt	
537	Analog Output Resolution								
5371	Analog Output Resolution on the Control Panel	1%	43199	169/103	4C7F	19583	UInt	UInt	
5372	Analog Output Resolution in Communication	1%	43200	169/104	4C80	19584	UInt	UInt	
540	Digital Outputs [540]								
541	DigOut 1	Ready	43271	169/175	4CC7	19655	UInt	UInt	
542	DigOut2	Brake	43272	169/176	4CC8	19656	UInt	UInt	
550	Relays [550]								
551	Relay 1	Trip	43273	169/177	4CC9	19657	UInt	UInt	
552	Relay 2	Run	43274	169/178	4CCA	19658	UInt	UInt	

Menu Parameters		Default settings	Modbus Instance/ Device Net No.	Profibus slot/index	EtherCAT index (HEX)	Profinet index	Fieldbus format	Modbus format	Notes
553	Relay 3	Off	43275	169/179	4CCB	19659	UInt	UInt	
554	B1 Relay 1	Off	43511	170/160	4DB7	19895	UInt	UInt	
555	B1 Relay 2	Off	43512	170/161	4DB8	19896	UInt	UInt	
556	B1 Relay 3	Off	43513	170/162	4DB9	19897	UInt	UInt	
557	B2 Relay 1	Off	43514	170/163	4DBA	19898	UInt	UInt	
558	B2 Relay 2	Off	43515	170/164	4DBB	19899	UInt	UInt	
559	B2 Relay 3	Off	43516	170/165	4DBC	19900	UInt	UInt	
55A	B3 Relay 1	Off	43517	170/166	4DBD	19901	UInt	UInt	
55B	B3 Relay 2	Off	43518	170/167	4DBE	19902	UInt	UInt	
55C	B3 Relay 3	Off	43519	170/168	4DBF	19903	UInt	UInt	
55D	Relay Advan								
55D1	Relay1 Mode	N.O	43276	169/180	4CCC	19660	UInt	UInt	
55D2	Relay2 Mode	N.O	43277	169/181	4CCD	19661	UInt	UInt	
55D3	Relay3 Mode	N.O	43278	169/182	4CCE	19662	UInt	UInt	
55D4	B1R1 Mode	N.O	43521	170/170	4DC1	19905	UInt	UInt	
55D5	B1R2 Mode	N.O	43522	170/171	4DC2	19906	UInt	UInt	
55D6	B1R3 Mode	N.O	43523	170/172	4DC3	19907	UInt	UInt	
55D7	B2R1 Mode	N.O	43524	170/173	4DC4	19908	UInt	UInt	
55D8	B2R2 Mode	N.O	43525	170/174	4DC5	19909	UInt	UInt	
55D9	B2R3 Mode	N.O	43526	170/175	4DC6	19910	UInt	UInt	
55DA	B3R1 Mode	N.O	43527	170/176	4DC7	19911	UInt	UInt	
55DB	B3R2 Mode	N.O	43528	170/177	4DC8	19912	UInt	UInt	
55DC	B3R3 Mode	N.O	43529	170/178	4DC9	19913	UInt	UInt	
560	Virtual Connections [560]								
561	VIO 1 Dest	Off	43281	169/185	4CD1	19665	UInt	UInt	
562	VIO 1 Source	Off	43282	169/186	4CD2	19666	UInt	UInt	
563	VIO 2 Dest	Off	43283	169/187	4CD3	19667	UInt	UInt	
564	VIO 2 Source	Off	43284	169/188	4CD4	19668	UInt	UInt	
565	VIO 3 Dest	Off	43285	169/189	4CD5	19669	UInt	UInt	
566	VIO 3 Source	Off	43286	169/190	4CD6	19670	UInt	UInt	
567	VIO 4 Dest	Off	43287	169/191	4CD7	19671	UInt	UInt	
568	VIO 4 Source	Off	43288	169/192	4CD8	19672	UInt	UInt	
569	VIO 5 Dest	Off	43289	169/193	4CD9	19673	UInt	UInt	
56A	VIO 5 Source	Off	43290	169/194	4CDA	19674	UInt	UInt	
56B	VIO 6 Dest	Off	43291	169/195	4CDB	19675	UInt	UInt	
56C	VIO 6 Source	Off	43292	169/196	4CDC	19676	UInt	UInt	
56D	VIO 7 Dest	Off	43293	169/197	4CDD	19677	UInt	UInt	
56E	VIO 7 Source	Off	43294	169/198	4CDE	19678	UInt	UInt	

Menu Parameters		Default settings	Modbus Instance/ Device Net No.	Profibus slot/index	EtherCAT index (HEX)	Profinet index	Fieldbus format	Modbus format	Notes
56F	VIO 8 Dest	Off	43295	169/199	4CDF	19679	UInt	UInt	
56G	VIO 8 Source	STO Active	43296	169/200	4CE0	19680	UInt	UInt	
600	Logical Functions and Timers [600]								
610	Comparators [610]								
611	Setup Analogue Comparator 1 [611]								
6111	CA1 Value	Speed	43400	170/49	4D48	19784	UInt	UInt	
6112	CA1 LevelHI	300rpm	43401	170/50	4D49	19785	Long, 1=0.001	EInt	
6113	CA1 LevelLO	200rpm	43402	170/51	4D4A	19786	Long, 1=0.001	EInt	
6114	CA1 Type	Hysteresis	43403	170/52	4D4B	19787	UInt	UInt	
6115	CA1 Polar	Unipolar	43404	170/53	4D4C	19788	UInt	UInt	
6116	CA1 Set Dly	0s	43405	170/54	4D4D	19789	Long, 1=1s	EInt	
6117	CA1 Res Dly	0s	43406	170/55	4D4E	19790	Long, 1=1s	EInt	
6118	CA1 Tmr Val	0s	43407	170/56	4D4F	19791	Long, 1=1s	EInt	
612	CA2 Setup [612]								
6121	CA2 Value	Torque	43408	170/57	4D50	19792	UInt	UInt	
6122	CA2 LevelHI	20	43409	170/58	4D51	19793	Long, 1=0.001	EInt	
6123	CA2 LevelLO	10	43410	170/59	4D52	19794	Long, 1=0.001	EInt	
6124	CA2 Type	Hysteresis	43411	170/60	4D53	19795	UInt	UInt	
6125	CA2 Polar	Unipolar	43412	170/61	4D54	19796	UInt	UInt	
6126	CA2 Set Dly	0s	43413	170/62	4D55	19797	Long, 1=1s	EInt	
6127	CA2 Res Dly	0s	43414	170/63	4D56	19798	Long, 1=1s	EInt	
6128	CA2 Tmr Val	0s	43415	170/64	4D57	19799	Long, 1=1s	EInt	
613	CA3 Setup [613]								
6131	CA3 Value	Process Val	43416	170/65	4D58	19800	UInt	UInt	
6132	CA3 LevelHI	300	43417	170/66	4D59	19801	Long, 1=0.001	EInt	
6133	CA3 LevelLO	200	43418	170/67	4D5A	19802	Long, 1=0.001	EInt	
6134	CA3 Type	Hysteresis	43419	170/68	4D5B	19803	UInt	UInt	
6135	CA3 Polar	Unipolar	43420	170/69	4D5C	19804	UInt	UInt	
6136	CA3 Set Dly	0s	43421	170/70	4D5D	19805	Long, 1=1s	EInt	
6137	CA3 Res Dly	0s	43422	170/71	4D5E	19806	Long, 1=1s	EInt	
6138	CA3 Tmr Val	0s	43423	170/72	4D5F	19807	Long, 1=1s	EInt	
614	CA4 Setup [614]								
6141	CA4 Value	Process Err	43424	170/73	4D60	19808	UInt	UInt	
6142	CA4 LevelHI	100	43425	170/74	4D61	19809	Long, 1=0.001	EInt	
6143	CA4 LevelLO	-100	43426	170/75	4D62	19810	Long, 1=0.001	EInt	

Menu Parameters		Default settings	Modbus Instance/ Device Net No.	Profibus slot/index	EtherCAT index (HEX)	Profinet index	Fieldbus format	Modbus format	Notes
6144	CA4 Type	Window	43427	170/76	4D63	19811	UInt	UInt	
6145	CA4 Polar	Bipolar	43428	170/77	4D64	19812	UInt	UInt	
6146	CA4 Set Dly	0s	43429	170/78	4D65	19813	Long, 1=1s	Elnt	
6147	CA4 Res Dly	0s	43430	170/79	4D66	19814	Long, 1=1s	Elnt	
6148	CA4 Tmr Val	0s	43431	170/80	4D67	19815	Long, 1=1s	Elnt	
620	Analogue Multiplexer [620]								
621	AnMux1								
6211	AnMux1 InA	AnIn1	43432	170/81	4D68	19816	UInt	UInt	
6212	AnMux1 InB	AnIn2	43433	170/82	4D69	19817	UInt	UInt	
6213	AnMux1 Op	Off	43434	170/83	4D6A	19818	UInt	UInt	
622	AnMux2								
6221	AnMux2 InA	AnIn1	43435	170/84	4D6B	19819	UInt	UInt	
6222	AnMux2 InB	AnIn2	43436	170/85	4D6C	19820	UInt	UInt	
6223	AnMux2 Op	Off	43437	170/86	4D6D	19821	UInt	UInt	
630	Not Gate [630]								
631	NOT1 Input	CA2	43438	170/87	4D6E	19822	UInt	UInt	
632	NOT2 Input	Off	43439	170/88	4D6F	19823	UInt	UInt	
633	NOT3 Input	Off	43440	170/89	4D70	19824	UInt	UInt	
634	NOT4 Input	Off	43441	170/90	4D71	19825	UInt	UInt	
635	NOT5 Input	Off	43442	170/91	4D72	19826	UInt	UInt	
636	NOT6 Input	Off	43443	170/92	4D73	19827	UInt	UInt	
637	NOT7 Input	Off	43444	170/93	4D74	19828	UInt	UInt	
638	NOT8 Input	Off	43445	170/94	4D75	19829	UInt	UInt	
640	Logic output [640]								
641	Logic Output 1 [641]								
6411	L1 Expr	((1.2).3).4	43450	170/99	4D7A	19834	UInt	UInt	
6412	L1 Input 1	CA1	43451	170/100	4D7B	19835	UInt	UInt	
6413	L1 Op 1	&	43452	170/101	4D7C	19836	UInt	UInt	
6414	L1 Input 2	NOT1	43453	170/102	4D7D	19837	UInt	UInt	
6415	L1 Op 2	&	43454	170/103	4D7E	19838	UInt	UInt	
6416	L1 Input 3	Run	43455	170/104	4D7F	19839	UInt	UInt	
6417	L1 Op 3	.	43456	170/105	4D80	19840	UInt	UInt	
6418	L1 Input 4	Off	43457	170/106	4D81	19841	UInt	UInt	
6419	L1 Set Dly	0s	43458	170/107	4D82	19842	Long, 1=1s	Elnt	
641A	L1 Res Dly	0s	43459	170/108	4D83	19843	Long, 1=1s	Elnt	
641B	L1 Tmr Val	0s	43460	170/109	4D84	19844	Long, 1=1s	Elnt	
642	Logic 2								

Menu Parameters		Default settings	Modbus Instance/ Device Net No.	Profibus slot/index	EtherCAT index (HEX)	Profinet index	Fieldbus format	Modbus format	Notes
6421	L2 Expr	((1.2).3).4	43461	170/110	4D85	19845	UInt	UInt	
6422	L2 Input 1	CA1	43462	170/111	4D86	19846	UInt	UInt	
6423	L2 Op 1	&	43463	170/112	4D87	19847	UInt	UInt	
6424	L2 Input 2	NOT1	43464	170/113	4D88	19848	UInt	UInt	
6425	L2 Op 2	&	43465	170/114	4D89	19849	UInt	UInt	
6426	L2 Input 3	Run	43466	170/115	4D8A	19850	UInt	UInt	
6427	L2 Op 3	.	43467	170/116	4D8B	19851	UInt	UInt	
6428	L2 Input 4	Off	43468	170/117	4D8C	19852	UInt	UInt	
6429	L2 Set Dly	0s	43469	170/118	4D8D	19853	Long, 1=1s	EInt	
642A	L2 Res Dly	0s	43470	170/119	4D8E	19854	Long, 1=1s	EInt	
642B	L2 Tmr Val	0s	43471	170/120	4D8F	19855	Long, 1=1s	EInt	
643	Logic 3								
6431	L3 Expr	((1.2).3).4	43472	170/121	4D90	19856	UInt	UInt	
6432	L3 Input 1	CA1	43473	170/122	4D91	19857	UInt	UInt	
6433	L3 Op 1	&	43474	170/123	4D92	19858	UInt	UInt	
6434	L3 Input 2	NOT1	43475	170/124	4D93	19859	UInt	UInt	
6435	L3 Op 2	&	43476	170/125	4D94	19860	UInt	UInt	
6436	L3 Input 3	Run	43477	170/126	4D95	19861	UInt	UInt	
6437	L3 Op 3	.	43478	170/127	4D96	19862	UInt	UInt	
6438	L3 Input 4	Off	43479	170/128	4D97	19863	UInt	UInt	
6439	L3 Set Dly	0s	43480	170/129	4D98	19864	Long, 1=1s	EInt	
643A	L3 Res Dly	0s	43481	170/130	4D99	19865	Long, 1=1s	EInt	
643B	L3 Tmr Val	0s	43482	170/131	4D9A	19866	Long, 1=1s	EInt	
644	Logic 4								
6441	L4 Expr	((1.2).3).4	43483	170/132	4D9B	19867	UInt	UInt	
6442	L4 Input 1	CA1	43484	170/133	4D9C	19868	UInt	UInt	
6443	L4 Op 1	&	43485	170/134	4D9D	19869	UInt	UInt	
6444	L4 Input 2	NOT1	43486	170/135	4D9E	19870	UInt	UInt	
6445	L4 Op 2	&	43487	170/136	4D9F	19871	UInt	UInt	
6446	L4 Input 3	Run	43488	170/137	4DA0	19872	UInt	UInt	
6447	L4 Op 3	.	43489	170/138	4DA1	19873	UInt	UInt	
6448	L4 Input 4	Off	43490	170/139	4DA2	19874	UInt	UInt	
6449	L4 Set Dly	0s	43491	170/140	4DA3	19875	Long, 1=1s	EInt	
644A	L4 Res Dly	0s	43492	170/141	4DA4	19876	Long, 1=1s	EInt	
644B	L4 Tmr Val	0s	43493	170/142	4DA5	19877	Long, 1=1s	EInt	
650	Timers [650]								
651	Timer1								
6511	Timer1 Trig	Off	43600	170/249	4E10	19984	UInt	UInt	
6512	Timer1 Mode	Off	43601	170/250	4E11	19985	UInt	UInt	

Menu Parameters		Default settings	Modbus Instance/ Device Net No.	Profibus slot/index	EtherCAT index (HEX)	Profinet index	Fieldbus format	Modbus format	Notes
6514	Timer1 T1/D	0s	43603	170/252	4E13	19987	Long, 1=0.1s	Elnt	
6515	Timer1 T2	0s	43604	170/253	4E14	19988	Long, 1=1s	Elnt	
6516	Timer1Value	0s	43605	170/254	4E15	19989	Long, 1=1s	Elnt	
652	Timer2								
6521	Timer2 Trig	Off	43606	171/0	4E16	19990	Ulnnt	Ulnnt	
6522	Timer2 Mode	Off	43607	171/1	4E17	19991	Ulnnt	Ulnnt	
6524	Timer2 T1/D	0s	43609	171/3	4E19	19993	Long, 1=0.1s	Elnt	
6525	Timer2 T2	0s	43610	171/4	4E1A	19994	Long, 1=1s	Elnt	
6526	Timer2Value	0s	43611	171/5	4E1B	19995	Long, 1=1s	Elnt	
653	Timer3								
6531	Timer3 Trig	Off	43612	171/6	4E1C	19996	Ulnnt	Ulnnt	
6532	Timer3 Mode	Off	43613	171/7	4E1D	19997	Ulnnt	Ulnnt	
6534	Timer3 T1/D	0s	43615	171/9	4E1F	19999	Long, 1=0.1s	Elnt	
6535	Timer3 T2	0s	43616	171/10	4E20	20000	Long, 1=1s	Elnt	
6536	Timer3Value	0s	43617	171/11	4E21	20001	Long, 1=1s	Elnt	
654	Timer4								
6541	Timer4 Trig	Off	43618	171/12	4E22	20002	Ulnnt	Ulnnt	
6542	Timer4 Mode	Off	43619	171/13	4E23	20003	Ulnnt	Ulnnt	
6544	Timer4 T1/D	0s	43621	171/15	4E25	20005	Long, 1=0.1s	Elnt	
6545	Timer4 T2	0s	43622	171/16	4E26	20006	Long, 1=1s	Elnt	
6546	Timer4Value	0s	43623	171/17	4E27	20007	Long, 1=1s	Elnt	
660	Flip flops [660]								
661	Flip flop 1								
6611	F1 mode	Reset	43630	171/24	4E2E	20014	Ulnnt	Ulnnt	
6612	F1 set	Off	43631	171/25	4E2F	20015	Ulnnt	Ulnnt	
6613	F1 reset	Off	43632	171/26	4E30	20016	Ulnnt	Ulnnt	
6614	F1 set Dly	0s	43633	171/27	4E31	20017	Long, 1=1s	Elnt	
6615	F1 res Dly	0s	43634	171/28	4E32	20018	Long, 1=1s	Elnt	
6616	F1 Tmr Val	0s	43635	171/29	4E33	20019	Long, 1=1s	Elnt	
662	Flip flop 2								
6621	F2 mode	Reset	43636	171/30	4E34	20020	Ulnnt	Ulnnt	
6622	F2 set	Off	43637	171/31	4E35	20021	Ulnnt	Ulnnt	
6623	F2 reset	Off	43638	171/32	4E36	20022	Ulnnt	Ulnnt	
6624	F2 Set Dly	0s	43639	171/33	4E37	20023	Long, 1=1s	Elnt	
6625	F2 Res Dly	0s	43640	171/34	4E38	20024	Long, 1=1s	Elnt	
6626	F2 Tmr Val	0s	43641	171/35	4E39	20025	Long, 1=1s	Elnt	
663	Flip flop 3								
6631	F3 mode	Reset	43642	171/36	4E3A	20026	Ulnnt	Ulnnt	
6632	F3 set	Off	43643	171/37	4E3B	20027	Ulnnt	Ulnnt	

Menu Parameters		Default settings	Modbus Instance/ Device Net No.	Profibus slot/index	EtherCAT index (HEX)	Profinet index	Fieldbus format	Modbus format	Notes
6633	F3 reset	Off	43644	171/38	4E3C	20028	Long	Elnt	
6634	F3 Set Dly	0s	43645	171/39	4E3D	20029	Long, 1=1s	Elnt	
6635	F3 Res Dly	0s	43646	171/40	4E3E	20030	Long, 1=1s	Elnt	
6636	F3 Tmr Val	0s	43647	171/41	4E3F	20031	Long, 1=1s	Elnt	
664	Flip flop 4								
6641	F4 mode	Reset	43648	171/42	4E40	20032	Ulnt	Ulnt	
6642	F4 set	Off	43649	171/43	4E41	20033	Ulnt	Ulnt	
6643	F4 reset	Off	43650	171/44	4E42	20034	Ulnt	Ulnt	
6644	F4 Set Dly	0s	43651	171/45	4E43	20035	Long, 1=1s	Elnt	
6645	F4 Res Dly	0s	43652	171/46	4E44	20036	Long, 1=1s	Elnt	
6646	F4 Tmr Val	0s	43653	171/47	4E45	20037	Long, 1=1s	Elnt	
670	Counters [670]								
671	Counter1								
6711	C1 Trig	Off	43654	171/48	4E46	20038	Ulnt	Ulnt	
6712	C1 Reset	Off	43655	171/49	4E47	20039	Ulnt	Ulnt	
6713	C1 High Val	0	43656	171/50	4E48	20040	Long, 1=1	Elnt	
6714	C1 Low Val	0	43657	171/51	4E49	20041	Long, 1=1	Elnt	
6715	C1 DecTimer	Off	43658	171/52	4E4A	20042	Long, 1=1s	Elnt	
6719	C1 Value	0	43659	171/53	4E4B	20043	Ulnt, 1=1	Ulnt	
672	Counter2								
6721	C2 Trig	Off	43660	171/54	4E4C	20044	Ulnt	Ulnt	
6722	C2 Reset	Off	43661	171/55	4E4D	20045	Ulnt	Ulnt	
6723	C2 High Val	0	43662	171/56	4E4E	20046	Long, 1=1	Elnt	
6724	C2 High Val	0	43663	171/57	4E4F	20047	Long, 1=1	Elnt	
6725	C2 DecTimer	Off	43664	171/58	4E50	20048	Long, 1=1s	Elnt	
6729	C2 Value	0	43665	171/59	4E51	20049	Ulnt, 1=1	Ulnt	
680	Clock Logic [680]								
681	Clock 1								
6811	Clk1TimeON	00:00:00	43670	171/64	4E56	20054	Long, 1=1h	Elnt	
			43671	171/65	4E57	20055	Long, 1=1m	Elnt	
			43672	171/66	4E58	20056	Long, 1=1s	Elnt	
6812	Clk1TimeOff	00:00:00	43673	171/67	4E59	20057	Long, 1=1h	Elnt	
			43674	171/68	4E5A	20058	Long, 1=1m	Elnt	
			43675	171/69	4E5B	20059	Long, 1=1s	Elnt	
6813	Clk1DateOn	2000-00-00	43676	171/70	4E5C	20060	Long, 1=1y	Elnt	
			43677	171/71	4E5D	20061	Long, 1=1m	Elnt	
			43678	171/72	4E5E	20062	Long, 1=1d	Elnt	

Menu Parameters		Default settings	Modbus Instance/ Device Net No.	Profibus slot/index	EtherCAT index (HEX)	Profinet index	Fieldbus format	Modbus format	Notes
6814	Clk1DateOff	2000-00-00	43679	171/73	4E5F	20063	Long, 1=1y	Elnt	
			43680	171/74	4E60	20064	Long, 1=1m	Elnt	
			43681	171/75	4E61	20065	Long, 1=1d	Elnt	
6815	Clk1Weekday	MTWTFSS	43682	171/76	4E62	20066	UInt, 1=1	UInt	
682	Clock 2								
6821	Clk2TimeON	00:00:00	43684	171/78	4E64	20068	Long, 1=1h	Elnt	
			43685	171/79	4E65	20069	Long, 1=1m	Elnt	
			43686	171/80	4E66	20070	Long, 1=1s	Elnt	
6822	Clk2TimeOff	00:00:00	43687	171/81	4E67	20071	Long, 1=1h	Elnt	
			43688	171/82	4E68	20072	Long, 1=1m	Elnt	
			43689	171/83	4E69	20073	Long, 1=1s	Elnt	
6823	Clk2DateOn	2000-00-00	43690	171/84	4E6A	20074	Long, 1=1y	Elnt	
			43691	171/85	4E6B	20075	Long, 1=1m	Elnt	
			43692	171/86	4E6C	20076	Long, 1=1d	Elnt	
6824	Clk2DateOff	2000-00-00	43693	171/87	4E6D	20077	Long, 1=1y	Elnt	
			43694	171/88	4E6E	20078	Long, 1=1m	Elnt	
			43695	171/89	4E6F	20079	Long, 1=1d	Elnt	
6825	Clk2Weekday	MTWTFSS	43696	171/90	4E70	20080	UInt, 1=1	UInt	
700	View Operation/Status [700]								
710	Operation [710]								
711	Process Val		31001	121/145	23E9	1001	Long, 1=0.001	Elnt	
712	Speed		31002	121/146	23EA	1002	Int, 1=1rpm	Int	
713	Torque		31003	121/147	23EB	1003	Long, 1=0.1Nm	Elnt	
			31004	121/148	23EC	1004	Long, 1=1%	Elnt	
714	Shaft Power		31005	121/149	23ED	1005	Long, 1=1W	Elnt	
715	El Power		31006	121/150	23EE	1006	Long, 1=1W	Elnt	
716	Current		31007	121/151	23EF	1007	Long, 1=0.1A	Elnt	
717	Output Volt		31008	121/152	23F0	1008	Long, 1=0.1V	Elnt	
718	Frequency		31009	121/153	23F1	1009	Long, 1=0.1Hz	Elnt	
719	DC Voltage		31010	121/154	23F2	1010	Long, 1=0.1V	Elnt	
71A	IGBT Temp		31011	121/155	23F3	1011	Long, 1=0.1°C	Elnt	
71B	PT100 1,2,3		31012	121/156	23F4	1012	Long, 1=1°C	Elnt	
			31013	121/157	23F5	1013	Long, 1=1°C	Elnt	
			31014	121/158	23F6	1014	Long, 1=1°C	Elnt	
71C	PT100 4,5,6		31097	121/241	2449	1097	Long, 1=1°C	Elnt	
			31098	121/242	244A	1098	Long, 1=1°C	Elnt	
			31099	121/243	244B	1099	Long, 1=1°C	Elnt	

Menu Parameters		Default settings	Modbus Instance/ Device Net No.	Profibus slot/index	EtherCAT index (HEX)	Profinet index	Fieldbus format	Modbus format	Notes
720	Status [720]								
721	VSD Status		31015	121/159	23F7	1015	UInt	UInt	
722	Warning		31016	121/160	23F8	1016	UInt	UInt	
723	DigIn Status		31017	121/161	23F9	1017	UInt, 1=1	UInt	
724	DigOutStatus		31018	121/162	23FA	1018	UInt, 1=1	UInt	
725	AnIn 1 2		31019	121/163	23FB	1019	Long, 1=1%	EInt	
			31020	121/164	23FC	1020	Long, 1=1%	EInt	
726	AnIn 3 4		31021	121/165	23FD	1021	Long, 1=1%	EInt	
			31022	121/166	23FE	1022	Long, 1=1%	EInt	
727	AnOut 1 2		31023	121/167	23FF	1023	Long, 1=1%	EInt	
			31024	121/168	2400	1024	Long, 1=1%	EInt	
728	IO Status B1		31025	121/169	2401	1025	UInt, 1=1	UInt	
729	IO Status B2		31026	121/170	2402	1026	UInt, 1=1	UInt	
72A	IO Status B3		31027	121/171	2403	1027	UInt, 1=1	UInt	
72B	Area D Stat								
72B1	Area D LSB		30180	118/89	20B4	180	UInt, 1=1	UInt	
72B2	Area D MSB		30182	118/91	20B6	182	UInt, 1=1	UInt	
72C	VIO Status		30181	118/90	20B5	181	UInt, 1=1	UInt	
72D	Run Status	0	31036	121/180	20C	1036	UInt	UInt	
730	Stored values [730]								
731	Run Time		31028	121/172	2404	1028	Long, 1=1h	EInt	
			31029	121/173	2405	1029	Long, 1=1m	EInt	
			31030	121/174	2406	1030	Long, 1=1s	EInt	
7311	Reset RunTm	No	7	0/6	2007	7	UInt	UInt	
732	Mains Time	hh:mm:ss	31031	121/175	2407	1031	Long, 1=1h	EInt	
			31032	121/176	2408	1032	Long, 1=1m	EInt	
			31033	121/177	2409	1033	Long, 1=1s	EInt	
733	Energy	Wh	31034	121/178	240A	1034	Long, 1=1Wh	EInt	
7331	Rst Energy	No	6	0/5	2006	6	UInt	UInt	
800	View Trip Log [800]								
810	Trip message log [810]		31101	121/245	244D	1101	UInt, 1=1	UInt	
811	Process Val		31102	121/246	244E	1102	Long, 1=0.001	EInt	
812	Speed		31103	121/247	244F	1103	Int, 1=1rpm	Int	
813	Torque		31104	121/248	2450	1104	Long, 1=0.1Nm	EInt	
			31105	121/249	2451	1105	Long, 1=1%	EInt	
814	Shaft Power		31106	121/250	2452	1106	Long, 1=1W	EInt	
815	EI Power		31107	121/251	2453	1107	Long, 1=1W	EInt	

Menu Parameters		Default settings	Modbus Instance/ Device Net No.	Profibus slot/index	EtherCAT index (HEX)	Profinet index	Fieldbus format	Modbus format	Notes
816	Current		31108	121/252	2454	1108	Long, 1=0.1A	Elnt	
817	Output volt		31109	121/253	2455	1109	Long, 1=0.1V	Elnt	
818	Frequency		31110	121/254	2456	1110	Long, 1=0.1Hz	Elnt	
819	DC Voltage		31111	122/0	2457	1111	Long, 1=0.1V	Elnt	
81A	IGBT Temp		31112	122/1	2458	1112	Long, 1=0.1 °C	Elnt	
81B	PT100 1,2,3		31113	122/2	2459	1113	Long, 1=1 °C	Elnt	
			31114	122/3	245A	1114	Long, 1=1 °C	Elnt	
			31115	122/4	245B	1115	Long, 1=1 °C	Elnt	
81C	VSD Status		31116	122/5	245C	1116	Ulnt	Ulnt	
81D	DigIn Status		31117	122/6	245D	1117	Ulnt, 1=1	Ulnt	
81E	DigOutStatus		31118	122/7	245E	1118	Ulnt, 1=1	Ulnt	
81F	AnIn 1 2		31119	122/8	245F	1119	Long, 1=1%	Elnt	
			31120	122/9	2460	1120	Long, 1=1%	Elnt	
81G	AnIn 3 4		31121	122/10	2461	1121	Long, 1=1%	Elnt	
			31122	122/11	2462	1122	Long, 1=1%	Elnt	
81H	AnOut1 2		31123	122/12	2463	1123	Long, 1=1%	Elnt	
			31124	122/13	2464	1124	Long, 1=1%	Elnt	
81I	IO Status B1		31125	122/14	2465	1125	Ulnt, 1=1	Ulnt	
81J	IO Status B2		31126	122/15	2466	1126	Ulnt, 1=1	Ulnt	
81K	IO Status B3		31127	122/16	2467	1127	Ulnt, 1=1	Ulnt	
81L	Run Time		31128	122/17	2468	1128	Long, 1=1h	Elnt	
			31129	122/18	2469	1129	Long, 1=1m	Elnt	
			31130	122/19	246A	1130	Long, 1=1s	Elnt	
81M	Mains Time		31131	122/20	246B	1131	Long, 1=1h	Elnt	
			31132	122/21	246C	1132	Long, 1=1m	Elnt	
			31133	122/22	246D	1133	Long, 1=1s	Elnt	
81N	Energy		31147	122/36	247B	1147	Long, 1=1Wh	Elnt	
81O	Set/View ref		31135	122/24	246F	1135	Long, 1=0.001	Elnt	
81P	VIO Status		31136	122/25	2470	1136	Ulnt, 1=1	Ulnt	
81Q	PT100 4,5,6		31137	122/26	2471	1137	Long, 1=1 °C	Elnt	
			31138	122/27	2472	1138	Long, 1=1 °C	Elnt	
			31139	122/28	2473	1139	Long, 1=1 °C	Elnt	
820	Trip Message (Log 2)		31151 to 31189	122/40 to 122/78	247F to 24A5	1151 to 1189			
830	Trip Message (Log 3)		31201 to 31239	122/90 to 122/128	24B1 to 24D7	1201 to 1239			
840	Trip Message (Log 4)		31251 to 31289	122/140 to 122/178	24E3 to 2509	1251 to 1289			

Menu Parameters		Default settings	Modbus Instance/ Device Net No.	Profibus slot/index	EtherCAT index (HEX)	Profinet index	Fieldbus format	Modbus format	Notes
850	Trip Message (Log 5)		31301 to 31339	122/190 to 122/228	2515 to 253B	1301 to 1339			
860	Trip Message (Log 6)		31351 to 31389	122/240 to 123/23	2547 to 256D	1351 to 1389			
870	Trip Message (Log 7)		31401 to 31439	123/35 to 123/73	2579 to 259F	1401 to 1439			
880	Trip Message (Log 8)		31451 to 31489	123/85 to 123/123	25AB to 25D1	1451 to 1489			
890	Trip Message (Log 9)		31501 to 31539	123/135 to 123/173	25DD to 2603	1501 to 1539			
8A0	Reset Trip L	No	8	0/7	2008	8	UInt	UInt	
900	System Data [900]								
920	VSD Data [920]								
921	VSD Type		31037	121/181	240D	1037	UInt, 1=1	UInt	
922	Software		31038	121/182	240E	1038	UInt	UInt	
			31039	121/183	240F	1039	UInt	UInt	
9221	Build Info	YYMMDDHHMM SS	31040	121/184	2410	1040	UInt	UInt	
			31041	121/185	2411	1041	UInt	UInt	
			31042	121/186	2412	1042	UInt	UInt	
			31043	121/187	2413	1043	UInt	UInt	
			31044	121/188	2414	1044	UInt	UInt	
			31045	121/189	2415	1045	UInt	UInt	
9222	Build ID								Read value using PPU or EmoSoftCom.
9223	EmoLib ID								Read value using PPU or EmoSoftCom.
9224	SW Config	0	31050	121/194	241A	1050	UInt, 1=1	UInt	
923	Unit Name	0	42301	165/225	48FD	18685	UInt	UInt	
			42302	165/226	48FE	18686	UInt	UInt	
			42303	165/227	48FF	18687	UInt	UInt	
			42304	165/228	4900	18688	UInt	UInt	
			42305	165/229	4901	18689	UInt	UInt	
			42306	165/230	4902	18690	UInt	UInt	
			42307	165/231	4903	18691	UInt	UInt	
			42308	165/232	4904	18692	UInt	UInt	
			42309	165/233	4905	18693	UInt	UInt	
			42310	165/234	4906	18694	UInt	UInt	
			42311	165/235	4907	18695	UInt	UInt	
			42312	165/236	4908	18696	UInt	UInt	

Menu Parameters		Default settings	Modbus Instance/ Device Net No.	Profibus slot/index	EtherCAT index (HEX)	Profinet index	Fieldbus format	Modbus format	Notes
924	Hardware								
9241	CB Key		39900	156/119	20D2	210	UInt	UInt	
925	CtrlPanel								
9251	CP SW ver		39901	156/120	46AD	9901	UInt	UInt	
9252	CP HW ver		39902	156/121	46AE	9902	UInt, 1=1	UInt	
9253	CP Build ID		30220	118/129	20DC	220	UInt	UInt	
930	Clock [930]								
931	Time	00:00:00	42601	167/15	4A29	18985	Long, 1=1h	Elnt	
			42602	167/16	4A2A	18986	Long, 1=1m	Elnt	
			42603	167/17	4A2B	18987	Long, 1=1s	Elnt	
932	Date	2000-00-00	42604	167/18	4A2C	18988	Long, 1=1y	Elnt	
			42605	167/19	4A2D	18989	Long, 1=1m	Elnt	
			42606	167/20	4A2E	18990	Long, 1=1d	Elnt	
933	Weekday	Monday	42607	167/21	4A2F	18991	Long	Elnt	
940	Inspection								
941	Interval	35 000h	42651	167/65	4A5B	19035	Long, 1=1h	Elnt	
942	Act.Counter	0h	42652	167/66	4A5C	19036	Long, 1=1h	Elnt	
943	Clear Cnt	No	10	0/9	200A	10	UInt	UInt	
950	Service Cont								
951	Company Name	Blank	42351	166/20	492F	18735	UInt	UInt	
			42352	166/21	4930	18736	UInt	UInt	
			42353	166/22	4931	18737	UInt	UInt	
			42354	166/23	4932	18738	UInt	UInt	
			42355	166/24	4933	18739	UInt	UInt	
			42356	166/25	4934	18740	UInt	UInt	
			42357	166/26	4935	18741	UInt	UInt	
			42358	166/27	4936	18742	UInt	UInt	
			42359	166/28	4937	18743	UInt	UInt	
			42360	166/29	4938	18744	UInt	UInt	
			42361	166/30	4930	18745	UInt	UInt	
			42362	166/31	493A	18746	UInt	UInt	
			42363	166/32	493B	18747	UInt	UInt	
			42364	166/33	493C	18748	UInt	UInt	
			42365	166/34	493D	18749	UInt	UInt	
42366	166/34	493E	18750	UInt	UInt				

Menu Parameters		Default settings	Modbus Instance/ Device Net No.	Profibus slot/index	EtherCAT index (HEX)	Profinet index	Fieldbus format	Modbus format	Notes
952	Phone Number	Blank	42367	166/36	493F	18751	UInt	UInt	
			42368	166/37	493F	18751	UInt	UInt	
			42369	166/38	4940	18752	UInt	UInt	
			42370	166/39	4941	18753	UInt	UInt	
			42371	166/40	4942	18754	UInt	UInt	
			42372	166/41	4943	18755	UInt	UInt	
			42373	166/42	4944	18756	UInt	UInt	
			42374	166/43	4945	18757	UInt	UInt	
			42375	166/44	4946	18758	UInt	UInt	
			42376	166/45	4947	18759	UInt	UInt	
953	AddressLine1	Blank	42377	166/46	4949	18761	UInt	UInt	
			42378	166/47	494A	18762	UInt	UInt	
			42379	166/48	494B	18763	UInt	UInt	
			42380	166/49	494C	18764	UInt	UInt	
			42381	166/50	494D	18765	UInt	UInt	
			42382	166/51	494E	18766	UInt	UInt	
			42383	166/52	494F	18767	UInt	UInt	
			42384	166/53	4950	18768	UInt	UInt	
			42385	166/54	4951	18769	UInt	UInt	
			42386	166/55	4952	18770	UInt	UInt	
			42387	166/56	4953	18771	UInt	UInt	
			42388	166/57	4954	18772	UInt	UInt	
			42389	166/58	4955	18773	UInt	UInt	
			42390	166/59	4956	18774	UInt	UInt	
42391	166/60	4957	18775	UInt	UInt				
42392	166/61	4958	18776	UInt	UInt				

Menu Parameters		Default settings	Modbus Instance/ Device Net No.	Profibus slot/index	EtherCAT index (HEX)	Profinet index	Fieldbus format	Modbus format	Notes
954	AddressLine2	Blank	42393	166/62	4959	18777	UInt	UInt	
			42394	166/63	495A	18778	UInt	UInt	
			42395	166/64	495B	18779	UInt	UInt	
			42396	166/65	495C	18780	UInt	UInt	
			42397	166/66	495D	18781	UInt	UInt	
			42398	166/67	495E	18782	UInt	UInt	
			42399	166/68	495F	18783	UInt	UInt	
			42400	166/69	4960	18784	UInt	UInt	
			42401	166/70	4961	18785	UInt	UInt	
			42402	166/71	4962	18786	UInt	UInt	
			42403	166/72	4963	18787	UInt	UInt	
			42404	166/73	4964	18788	UInt	UInt	
			42405	166/74	4965	18789	UInt	UInt	
			42406	166/75	4966	18790	UInt	UInt	
			42407	166/76	4967	18791	UInt	UInt	
42408	166/77	4968	18792	UInt	UInt				
955	AddressLine3	Blank	42409	166/78	4969	18793	UInt	UInt	
			42410	166/79	496A	18794	UInt	UInt	
			42411	166/80	496B	18795	UInt	UInt	
			42412	166/81	496C	18796	UInt	UInt	
			42413	166/82	496D	18797	UInt	UInt	
			42414	166/83	496E	18798	UInt	UInt	
			42415	166/84	496F	18799	UInt	UInt	
			42416	166/85	4970	18800	UInt	UInt	
			42417	166/86	4971	18801	UInt	UInt	
			42418	166/87	4972	18802	UInt	UInt	
			42419	166/88	4973	18803	UInt	UInt	
			42420	166/89	4974	18804	UInt	UInt	
			42421	166/90	4975	18805	UInt	UInt	
			42422	166/91	4976	18806	UInt	UInt	
			42423	166/92	4977	18807	UInt	UInt	
42424	166/93	4978	18808	UInt	UInt				

Menu Parameters		Default settings	Modbus Instance/ Device Net No.	Profibus slot/index	EtherCAT index (HEX)	Profinet index	Fieldbus format	Modbus format	Notes
956	Email Name	Blank	42425	166/94	4979	18809	UInt	UInt	
			42426	166/95	497A	18810	UInt	UInt	
			42427	166/96	497B	18811	UInt	UInt	
			42428	166/97	497C	18812	UInt	UInt	
			42429	166/98	497D	18813	UInt	UInt	
			42430	166/99	497E	18814	UInt	UInt	
			42431	166/100	497F	18815	UInt	UInt	
			42432	166/101	4980	18816	UInt	UInt	
			42433	166/102	4981	18817	UInt	UInt	
			42434	166/103	4982	18818	UInt	UInt	
			42435	166/104	4983	18819	UInt	UInt	
			42436	166/105	4984	18820	UInt	UInt	
			42437	166/106	4985	18821	UInt	UInt	
			42438	166/107	4986	18822	UInt	UInt	
42439	166/108	4987	18823	UInt	UInt				
42440	166/109	4988	18824	UInt	UInt				
957	Email Domain	@cgglobal.com	42441	166/110	4989	18825	UInt	UInt	
			42442	166/111	498A	18826	UInt	UInt	
			42443	166/112	498B	18827	UInt	UInt	
			42444	166/113	498C	18828	UInt	UInt	
			42445	166/114	498D	18829	UInt	UInt	
			42446	166/115	498E	18830	UInt	UInt	
			42447	166/116	498F	18831	UInt	UInt	
			42448	166/117	4990	18832	UInt	UInt	
			42449	166/118	4991	18833	UInt	UInt	
			42450	166/119	4992	18834	UInt	UInt	
			42451	166/120	4993	18835	UInt	UInt	
			42452	166/121	4994	18836	UInt	UInt	
			42453	166/122	4995	18837	UInt	UInt	
			42454	166/123	4996	18838	UInt	UInt	
42455	166/124	4997	18839	UInt	UInt				
42456	166/125	4998	18840	UInt	UInt				



# 16. EcoDesign product information per EU Directive 2019/1781

## 16.1 EcoDesign data for 400 V - IP20 and IP54 drive units

VFX	Rated supply voltage (V)	Rated supply frequency (Hz)	Rated output current (A)	Indicative motor rated power output (kW)	Rated apparent output power (kVA)	Max. operating temp (°C)	Efficiency level	Standby losses (%)	Ploss_rel (10;25)	Ploss_rel (10;50)	Ploss_rel (10;100)	Ploss_rel (50;25)	Ploss_rel (50;50)	Ploss_rel (50;100)	Ploss_rel (90;50)	Ploss_rel (90;100)
48-025-20	400	50	25	11	17,3	40	IE2	0,09	1,0	1,1	1,6	1,0	1,2	1,8	1,4	2,3
48-030-20			30	15	20,8		IE2	0,08	0,9	1,0	1,4	0,9	1,1	1,7	1,2	2,1
48-036-20			36	18,5	24,9		IE2	0,07	0,9	1,0	1,4	0,9	1,1	1,7	1,2	2,1
48-045-20			45	22	31,2		IE2	0,05	0,7	0,9	1,3	0,8	1,0	1,5	1,1	2,0
48-058-20			58	30	40,2		IE2	0,04	0,6	0,8	1,1	0,7	0,8	1,4	1,0	1,7
48-072-20			72	37	49,9		IE2	0,04	0,7	0,9	1,3	0,8	1,0	1,6	1,1	2,1
48-088-20			88	45	61,0		IE2	0,03	0,6	0,8	1,2	0,7	0,9	1,5	1,0	2,0
48-105-20			105	55	72,7		IE2	0,03	0,7	0,8	1,3	0,7	0,9	1,5	1,0	2,0
48-142-20			142	75	98,4		IE2	0,03	0,8	0,9	1,3	0,8	1,0	1,5	1,1	1,9
48-145-20			145	75	100,5		IE2	0,02	0,7	0,8	1,2	0,8	0,9	1,4	1,0	1,8
48-171-20			171	90	118,5		IE2	0,02	0,7	0,8	1,2	0,7	0,9	1,4	1,0	1,8
48-174-20			174	90	120,6		IE2	0,02	0,7	0,8	1,1	0,7	0,9	1,4	1,0	1,7
48-205-20			205	110	142,0		IE2	0,02	0,7	0,8	1,3	0,7	0,9	1,5	1,0	1,8
48-244-20			244	132	169,0		IE2	0,02	0,6	0,8	1,2	0,7	0,9	1,4	1,0	1,8
48-293-20			293	160	203,0		IE2	0,01	0,6	0,7	1,1	0,6	0,8	1,4	0,9	1,8
48-365-20			365	200	252,9		IE2	0,01	0,6	0,7	1,1	0,6	0,8	1,3	0,9	1,6
48-300-IP*			300	160	207,8		IE2	0,02	0,8	0,9	1,3	0,8	1,0	1,5	1,1	1,9
48-375-IP			375	200	259,8		IE2	0,02	0,7	0,8	1,2	0,7	0,9	1,4	1,0	1,8
48-430-IP			430	220	297,9		IE2	0,02	0,7	0,8	1,3	0,7	0,9	1,5	1,0	1,8
48-500-IP			500	250	346,4		IE2	0,01	0,6	0,7	1,2	0,7	0,8	1,4	0,9	1,8
48-590IP			590	315	408,8		IE2	0,01	0,6	0,7	1,1	0,6	0,8	1,4	0,9	1,8
48-600-IP			600	315	415,7		IE2	0,02	0,7	0,8	1,3	0,7	0,9	1,5	1,0	1,8
48-650-IP			650	355	450,3		IE2	0,01	0,7	0,8	1,2	0,7	0,9	1,5	1,0	1,8
48-660-IP			660	355	457,3		IE2	0,02	0,6	0,7	1,1	0,6	0,8	1,3	0,9	1,6
48-730-IP			730	400	505,8		IE2	0,01	0,6	0,7	1,1	0,6	0,8	1,3	0,9	1,6
48-750-IP			750	400	519,6		IE2	0,01	0,6	0,7	1,2	0,7	0,8	1,4	0,9	1,8
48-810-IP			810	450	561,2		IE2	0,02	0,6	0,7	1,1	0,6	0,8	1,4	0,9	1,8
48-860-IP			860	450	595,8		IE2	0,01	0,7	0,8	1,3	0,7	0,9	1,5	1,0	1,8
48-885-IP			885	500	613,1		IE2	0,01	0,6	0,7	1,1	0,6	0,8	1,4	0,9	1,8
48-1k0-IP			1000	560	692,8		IE2	0,01	0,6	0,7	1,2	0,7	0,8	1,4	0,9	1,8
48-1010-IP			1010	560	699,7		IE2	0,02	0,6	0,7	1,1	0,6	0,8	1,3	0,9	1,6
48-1100-IP			1100	630	762,1		IE2	0,01	0,6	0,7	1,1	0,6	0,8	1,3	0,9	1,6
48-1k15-IP			1150	630	796,7		IE2	0,01	0,6	0,8	1,2	0,7	0,9	1,4	1,0	1,8
48-1k25-IP			1250	710	866,0		IE2	0,01	0,6	0,7	1,2	0,7	0,8	1,4	0,9	1,8
48-1300-IP			1300	710	900,7		IE2	0,02	0,6	0,7	1,1	0,6	0,8	1,3	0,9	1,6
48-1k35-IP			1350	750	935,3		IE2	0,01	0,7	0,8	1,2	0,7	0,9	1,4	1,0	1,8
48-1460-IP			1460	800	1011,5		IE2	0,01	0,6	0,7	1,1	0,6	0,8	1,3	0,9	1,6
48-1k5-IP			1500	800	1039,2		IE2	0,01	0,6	0,7	1,2	0,7	0,8	1,4	0,9	1,8
48-1710-IP			1710	900	1184,7		IE2	0,01	0,6	0,7	1,1	0,6	0,8	1,3	0,9	1,8
48-1k75-IP			1750	900	1212,4		IE2	0,01	0,6	0,7	1,2	0,7	0,8	1,4	0,9	1,8
48-1820-IP	1820	1000	1260,9	IE2	0,01	0,6	0,7	1,1	0,6	0,8	1,3	0,9	1,6			

IP\*=IP20 or IP54

Relative power losses: Ploss\_rel (f,l), in % related to Rated apparent output power  
(f = Relative motor stator frequency, l = Relative torque producing current)

## 16.2 EcoDesign data for 400 V - IP54 drive units

VFX	Rated supply voltage (V)	Rated supply frequency (Hz)	Rated output current (A)	Indicative motor rated power output (kW)	Rated apparent output power (kVA)	Max. operating temp (°C)	Efficiency level	Standby losses (%)	Ploss_rel (10;25)	Plossrel (10;50)	Ploss_rel (10;100)	Ploss_rel (50;25)	Ploss_rel (50;50)	Ploss_rel (50;100)	Ploss_rel (90;50)	Ploss_rel (90;100)
48-003-54	400	50	2,5	0,75	1,7	40	IE2	0,91	4,5	4,6	4,8	4,5	4,7	5,0	4,8	5,3
48-004-54			4	1,5	2,8		IE2	0,57	3,4	3,5	3,8	3,4	3,6	4,0	3,7	4,4
48-006-54			6	2,2	4,2		IE2	0,38	2,4	2,5	2,8	2,4	2,6	3,0	2,7	3,4
48-008-54			7,5	3	5,2		IE2	0,30	2,3	2,4	2,7	2,3	2,5	3,0	2,7	2,5
48-010-54			9,5	4	6,6		IE2	0,24	1,9	2,0	2,3	1,9	2,1	2,6	2,3	3,2
48-013-54			13	5,5	9,0		IE2	0,18	2,9	2,8	2,1	2,7	2,6	2,4	2,4	2,9
48-018-54			18	7,5	12,5		IE2	0,13	2,5	2,3	1,6	2,3	2,2	2,0	2,0	2,6
48-026-54			26	11	18,0		IE2	0,09	1,0	1,1	1,5	1,0	1,2	1,8	1,3	2,1
48-031-54			31	15	21,5		IE2	0,07	0,8	1,0	1,4	0,9	1,1	1,6	1,2	2,0
48-037-54			37	18,5	25,6		IE2	0,06	0,8	1,0	1,5	0,9	1,1	1,6	1,2	2,0
48-046-54			46	22	31,9		IE2	0,05	0,7	0,9	1,3	0,8	0,9	1,5	1,1	1,9
48-061-54			61	30	42,3		IE2	0,05	0,8	0,9	1,4	0,8	1,0	1,7	1,2	2,1
48-074-54			74	37	51,3		IE2	0,04	0,7	0,8	1,3	0,8	0,9	1,5	1,1	2,0
48-090-54			90	45	62,4		IE2	0,04	0,9	1,1	1,5	1,0	1,2	1,7	1,3	2,1
48-109-54			109	55	75,5		IE2	0,03	0,8	1,0	1,4	0,9	1,0	1,6	1,2	1,9
48-145-54			145	75	100,5		IE2	0,02	0,7	0,8	1,2	0,8	0,9	1,4	1,0	1,8
48-146-54			146	75	101,2		IE2	0,03	0,8	0,9	1,3	0,8	1,0	1,5	1,1	1,9
48-174-54			174	90	120,6		IE2	0,02	0,7	0,8	1,1	0,7	0,9	1,4	1,0	1,7
48-175-54			175	90	121,2		IE2	0,02	0,7	0,8	1,2	0,7	0,9	1,4	1,0	1,8
48-210-54			210	110	145,5		IE2	0,02	0,7	0,8	1,3	0,7	0,9	1,5	1,0	1,8
48-250-54	250	132	173,2	IE2	0,02	0,6	0,8	1,2	0,7	0,8	1,4	1,0	1,7			
48-295-54	295	160	204,4	IE2	0,01	0,6	0,7	1,1	0,6	0,8	1,3	0,9	1,8			
48-365-54	365	200	252,9	IE2	0,01	0,6	0,7	1,1	0,6	0,8	1,3	0,9	1,6			

Relative power losses: Ploss\_rel (f;l), in % related to Rated apparent output power  
(f = Relative motor stator frequency, l = Relative torque producing current)

## 16.3 EcoDesign data for 525 V - IP54 drive units

VFX	Rated supply voltage (V)	Rated supply frequency (Hz)	Rated output current (A)	Indicative motor rated power output (kW)	Rated apparent output power (kVA)	Max. operating temp (°C)	Efficiency level	Standby losses (%)	Ploss_rel (10;25)	Ploss_rel (10;50)	Ploss_rel (10;100)	Ploss_rel (50;25)	Ploss_rel (50;50)	Ploss_rel (50;100)	Ploss_rel (90;50)	Ploss_rel (90;100)
52-003-54	525	50	2,5	1,1	2,3	40	IE2	0,71	3,7	3,8	4,0	3,7	3,9	4,2	3,9	4,4
52-004-54			4	2,2	3,6		IE2	0,44	2,8	3,0	3,3	2,9	3,0	3,4	3,1	3,7
52-006-54			6	3	5,5		IE2	0,30	2,0	2,1	2,3	2,0	2,2	2,5	2,3	2,9
52-008-54			7,5	4	6,8		IE2	0,24	2,0	2,1	2,3	2,0	2,1	2,6	2,3	2,9
52-010-54			9,5	5,5	8,6		IE2	0,19	1,5	1,6	2,0	1,6	1,7	2,2	1,9	2,7
52-013-54			13	7,5	11,8		IE2	0,14	2,4	2,3	1,8	2,2	2,1	2,1	2,0	2,4
52-018-54			18	11	16,4		IE2	0,10	2,0	1,9	1,4	1,9	1,8	1,7	1,7	2,1
52-026-54			26	15	23,6		IE2	0,07	0,8	0,9	1,3	0,8	1,0	1,5	1,1	1,7
52-031-54			31	18,5	28,2		IE2	0,06	0,7	0,8	1,2	0,7	0,9	1,3	1,0	1,6
52-037-54			37	22	33,6		IE2	0,05	0,7	0,8	1,2	0,7	0,9	1,4	1,0	1,6
52-046-54			46	30	41,8		IE2	0,04	0,6	0,7	1,1	0,6	0,8	1,2	0,9	1,5
52-061-54			61	37	55,5		IE2	0,04	0,7	0,8	1,2	0,7	0,9	1,4	1,0	1,8
52-074-54			74	45	67,3		IE2	0,03	0,6	0,7	1,1	0,6	0,8	1,3	0,9	1,7

Relative power losses: Ploss\_rel (f;I), in % related to Rated apparent output power  
(f = Relative motor stator frequency, I = Relative torque producing current)

## 16.4 EcoDesign data for 690 V - IP20 and IP54 drive units

VFX	Rated supply voltage (V)	Rated supply frequency (Hz)	Rated output current (A)	Indicative motor rated power output (kW)	Rated apparent output power (kVA)	Max. operating temp (°C)	Efficiency level	Standby losses (%)	Ploss_rel (10;25)	Ploss_rel (10;50)	Ploss_rel (10;100)	Ploss_rel (50;25)	Ploss_rel (50;50)	Ploss_rel (50;100)	Ploss_rel (90;50)	Ploss_rel (90;100)
69-002-IP*	690	50	2	1,5	2,4	40	IE1	0,93	6,4	6,6	7,0	6,4	6,6	7,1	6,7	7,2
69-003-IP			3	2,2	3,6		IE2	0,62	3,8	3,9	4,2	3,8	4,0	4,3	4,0	4,4
69-004-IP			4	3	4,8		IE2	0,47	2,7	2,8	3,0	2,7	2,8	3,1	2,9	3,3
69-006-IP			6	4	7,2		IE2	0,31	1,9	1,9	2,1	1,9	2,0	2,3	2,1	2,5
69-008-IP			8	5,5	9,6		IE2	0,23	1,4	1,5	1,7	1,4	1,5	1,8	1,5	1,9
69-010-IP			10	7,5	12,0		IE2	0,19	1,1	1,2	1,4	1,2	1,2	1,5	1,5	1,6
69-013-IP			13	11	15,5		IE2	0,14	0,9	0,9	1,1	0,9	1,0	1,2	1,0	1,4
69-018-IP			18	15	21,5		IE2	0,10	0,7	0,7	0,9	0,7	0,7	0,9	0,8	1,1
69-021-IP			21	18,5	25,1		IE2	0,09	0,6	0,6	0,8	0,6	0,7	0,9	0,7	1,0
69-025-IP			25	22	29,9		IE2	0,07	0,5	0,6	0,7	0,5	0,6	0,8	0,6	0,9
69-033-IP			33	30	39,4		IE2	0,06	1,2	1,4	1,9	1,2	1,4	2,0	1,5	2,3
69-042-IP			42	37	50,2		IE2	0,05	0,9	1,1	1,5	0,9	1,1	1,7	1,2	1,9
69-050-IP			50	45	59,8		IE2	0,04	0,8	1,0	1,5	0,8	1,0	1,6	1,1	1,9
69-058-IP			58	55	69,3		IE2	0,04	0,7	0,9	1,3	0,7	0,9	1,4	1,0	1,7
69-090-54			90	90	107,6		IE2	0,03	0,8	1,0	1,5	0,8	1,0	1,6	1,1	1,8
69-109-54			109	110	130,3		IE2	0,02	0,7	0,8	1,3	0,7	0,9	1,4	1,0	1,6
69-146-54			146	132	174,5		IE2	0,02	0,7	0,9	1,4	0,7	0,9	1,5	1,0	1,7
69-175-54			175	160	209,1		IE2	0,01	0,6	0,8	1,2	0,6	0,8	1,3	0,9	1,5
69-200-54			200	200	239,0		IE2	0,01	0,5	0,7	1,1	0,6	0,7	1,5	0,8	1,5
69-250-IP			250	250	298,8		IE2	0,02	0,8	0,9	1,5	0,8	1,0	1,7	1,1	1,8
69-300-IP			300	315	358,5		IE2	0,01	0,7	0,8	1,3	0,7	0,9	1,5	0,9	1,7
69-375-IP			375	355	448,2		IE2	0,01	0,6	0,7	1,1	0,6	0,8	1,3	0,8	1,5
69-400-IP			400	400	478,0		IE2	0,01	0,5	0,7	1,1	0,6	0,7	1,2	0,8	1,4
69-430-IP			430	450	513,9		IE2	0,01	0,7	0,9	1,4	0,7	0,9	1,5	1,0	1,7
69-500-IP			500	500	597,6		IE2	0,01	0,6	0,8	1,2	0,6	0,8	1,4	0,9	1,6
69-595-IP	600	600	717,1	IE2	0,01	0,5	0,7	1,1	0,6	0,7	1,2	0,8	1,5			
69-650-IP	650	630	776,8	IE2	0,01	0,6	0,8	1,3	0,6	0,8	1,4	0,9	1,6			
69-720-IP	720	710	860,5	IE2	0,01	0,6	0,7	1,2	0,6	0,8	1,3	0,8	1,5			
69-800-IP	800	800	956,1	IE2	0,01	0,5	0,7	1,1	0,6	0,7	1,2	0,8	1,5			
69-905-IP	900	900	1075,6	IE2	0,01	0,6	0,7	1,2	0,6	0,8	1,4	0,8	1,5			
69-995-IP	1000	1000	1195,1	IE2	0,01	0,5	0,7	1,1	0,6	0,7	1,2	0,8	1,5			

IP\*=IP20 or IP54

Relative power losses: Ploss\_rel (f,l), in % related to Rated apparent output power

(f = Relative motor stator frequency, l = Relative torque producing current)

# Index

## Symbols

+10VDC Supply voltage ..... 249  
+24VDC Supply voltage ..... 249

## Numerics

-10VDC Supply voltage ..... 249  
Menu.....109, 110, 128, 146, 147, 148,  
..... 161, 162, 163, 166, 169  
4-20mA ..... 172  
Menu  
..... 171, 173

## A

Abbreviations ..... 12  
Acceleration ..... 136, 138  
    Acceleration ramp ..... 138  
    Acceleration time ..... 136  
    Ramp type ..... 138  
Alarm trip ..... 165  
Alternating MASTER ..74, 77, 78, 154  
Analogue comparators ..... 186  
Analogue input ..... 171  
    AnIn1 ..... 171  
    AnIn2 ..... 175  
    Offset ..... 172, 180  
Analogue Output ..... 179, 181, 249  
    AnOut 1 ..... 179, 181  
    Output configuration ..... 180, 182  
AnIn Fault ..... 176  
AnIn2 ..... 175  
AnIn3 ..... 175  
AnIn4 ..... 175  
AnInFlt Set ..... 118  
Autoreset ..... 2, 68, 119, 219  
Autoreset Control ..... 119  
Autotune ..... 150

## B

Bluetooth (BLE) options ..... 131  
Brake function ..... 140, 141  
    Bake release time ..... 140  
    Brake ..... 142  
    Brake Engage Time ..... 142  
    Brake wait time ..... 142  
    Release speed ..... 142  
    Vector Brake ..... 142  
Brake functions  
    Frequency ..... 171  
Brake resistors ..... 227

## C

Cable specifications ..... 39  
Cascade controller ..... 73  
CE-marking ..... 11  
Change Condition ..... 155  
change sign of a value ..... 95, 97  
Change Timer ..... 155  
Checklist ..... 78  
Clockwise rotary field ..... 177

Comm & I/O ..... 122  
Comm Type ..... 125  
Communication fault ..... 126  
Connecting control signals ..... 54  
Connections  
    Brake chopper connections ..... 33  
    Control signal connections ..... 54  
    Mains supply ..... 33, 59  
    Motor earth ..... 33  
    Motor output ..... 33, 59  
    Safety earth ..... 33, 59  
Control Panel memory  
    Copy all settings to Control Panel 118  
    Frequency ..... 171  
Control signal connections ..... 54  
Control signals ..... 50, 56  
    Edge-controlled ..... 69, 104  
    Level-controlled ..... 68, 104  
Counter-clockwise rotary field ..... 177  
CP units ..... 105  
Crane ..... 124  
Crane Option ..... 165  
Crane options ..... 161  
Current ..... 51  
Current control (0-20mA) ..... 57

## D

Date ..... 94, 214  
DC-link residual voltage ..... 2  
Deceleration ..... 137  
    Deceleration time ..... 137  
    Ramp type ..... 138  
Declaration of Conformity ..... 11  
Default ..... 117  
Definitions ..... 12  
Digital inputs  
    Board Relay ..... 185  
    DigIn 1 ..... 177  
    DigIn 2 ..... 179  
    DigIn 3 ..... 179  
Dismantling and scrapping ..... 12  
Display ..... 91  
Double-ended connection ..... 56  
Drive mode ..... 101  
    Frequency ..... 171  
Drive protection ..... 119  
Drives on Change ..... 155

## E

Edge control ..... 69, 104  
Electrical ..... 204  
Electrical specification ..... 238  
EMC ..... 33  
    Current control (0-20mA) ..... 57  
    Double-ended connection ..... 56  
    RFI mains filter ..... 33  
    Single-ended connection ..... 56  
    Twisted cables ..... 57  
Emergency stop ..... 83  
EmoSoftCom ..... 226  
Emotron Dedicated Pump ..... 154  
EN60204-1 ..... 11

EN61800-5-1 .....	11
Enable .....	67, 94, 177
Encoder fault and speed monitoring	110
EtherCAT .....	229
Ethernet .....	128
External trips .....	124

## F

Factory settings .....	117
Fail safe .....	75
Fans .....	154
FB status .....	129
Feedback 'Status' input .....	74
Fieldbus .....	85, 125
Fieldbus signals .....	128
Fixed MASTER .....	78, 154
Flux optimization .....	147
Frequency	
Frequency priority .....	67
Jog Frequency .....	145
Maximum Frequency .....	144
Minimum Frequency .....	144
Preset Frequency .....	149
Skip Frequency .....	145
Frequency priority .....	67
Fuses and glands .....	244

## G

General electrical specifications .....	238
Gland kits .....	226
Global parameters .....	116

## H

Handheld Control Panel 2.0 .....	226
Hydrophore controller .....	73

## I

I/O Board .....	228
I/O board option .....	73
I2t protection	
Motor I2t Current .....	114, 115
Motor I2t Type .....	113
ID run .....	70, 108
Identification Run .....	70, 108
IEC269 .....	244
Industrial Ethernet .....	229
Internal speed control .....	150
Internal speed controller .....	150
Speed I Time .....	150
Speed P Gain .....	150
Interrupt .....	127, 128, 129
IT Mains supply .....	2
IxR Compensation .....	146

## J

Jog Frequency .....	145
---------------------	-----

## K

Keyboard reference .....	149
Keys .....	94
- Key .....	96
+ Key .....	96

Control keys .....	94
ENTER key .....	96
ESCAPE key .....	96
Function keys .....	96
NEXT key .....	96
PREVIOUS key .....	96
RUN L .....	94
RUN R .....	94
STOP/RESET .....	94
Toggle Key .....	95

## L

LCD display .....	91
Level control .....	68, 104
Liquid cooling .....	229
Load default .....	117
Load monitor .....	71, 123, 165
Local/Remote .....	103
Lock code .....	103, 105
Long motor cables .....	35
Low Voltage Directive .....	11

## M

Machine Directive .....	11
Main menu .....	97
Mains supply .....	33, 49, 59
Maintenance .....	224
Manis cables .....	30
Max Frequency .....	136, 144
Memory .....	70
Menu	
(110) .....	100
(120) .....	100
(211) .....	101
(212) .....	101
(213) .....	101
(214) .....	102
(215) .....	103
(216) .....	103
(217) .....	103
(218) .....	103, 105
(219) .....	104
(21A) .....	104
(21B) .....	104
(21E) .....	105
(21E1) .....	105
(21E2) .....	105
(21E3) .....	105
(220) .....	106
(221) .....	106
(222) .....	106
(223) .....	106
(224) .....	106
(225) .....	107
(226) .....	107
(227) .....	107
(228) .....	107
(229) .....	108
(22B) .....	108
(22C) .....	108
(22D) .....	108
(22E2) .....	110

(22E21) .....	110	(2571) .....	124
(22E22) .....	110	(2572) .....	124
(22E23) .....	110	(258) .....	124
(22E3) .....	110	(2581) .....	124
(22G4) .....	111	(2582) .....	124
(230) .....	113	(2583) .....	124
(231) .....	113	(2584) .....	124
(232) .....	114	(2585) .....	124
(233) .....	114	(2586) .....	124
(234) .....	115, 116	(2587) .....	124
(235) .....	115	(2588) .....	124
(236) .....	115	(260) .....	125
(237) .....	116	(261) .....	125
(240) .....	116	(262) .....	125
(241) .....	116	(2621) .....	125
(242) .....	117	(2622) .....	125
(243) .....	117	(263) .....	125
(244) .....	118	(2631) .....	125
(245) .....	118	(2632) .....	126
(247) .....	118	(2633) .....	126
(250) .....	119	(2634) .....	126
(251) .....	119	(2635) .....	126
(2511) .....	119	(264) .....	126
(2512) .....	119	(2641) .....	127
(252) .....	119	(2642) .....	127
(2521) .....	119	(2643) .....	127
(2522) .....	119	(2644) .....	127
(2523) .....	120	(2645) .....	127
(2524) .....	120	(2646) .....	127
(2525) .....	120	(2647) .....	128
(2526) .....	120	(2648) .....	128
(2527) .....	120	(265) .....	128
(2528) .....	120	(2651) .....	128
(2529) .....	120	(2652) .....	128
(253) .....	120	(2653) .....	128
(2531) .....	120	(2654) .....	128
(2532) .....	120	(2655) .....	128
(2533) .....	120	(2656) .....	128
(2534) .....	121	(2657) .....	128
(2535) .....	121	(2661)-(2668) .....	128
(2536) .....	121	(2669)-(266G) .....	129
(2537) .....	121	(269) .....	129
(2538) .....	121	(270) .....	129
(2539) .....	121	(271) .....	129
(253A) .....	121	(272) .....	129
(253B) .....	121	(2721) .....	129
(253C) .....	121	(2722) .....	130
(253D) .....	121	(2723) .....	130
(253E) .....	122	(2724) .....	130
(253F) .....	122	(2725) .....	130
(254) .....	122	(2726) .....	130
(2541) .....	122	(2727) .....	130
(2542) .....	122	(2728) .....	130
(2543) .....	122	(2729) .....	130
(2544) .....	122	(272A) .....	131
(255) .....	123	(273) .....	131
(2551) .....	123	(2731) .....	131
(2552) .....	123	(2732) .....	131
(2553) .....	123	(274) .....	131
(2554) .....	123	(2741) .....	131
(2556) .....	123	(2742) .....	131
(2561) .....	123	(300) .....	132
(257) .....	124	(310) .....	132

(320) .....	133	(3913) .....	154
(321) .....	133	(3914) .....	155
(322) .....	133	(3915) .....	155
(323) .....	134	(3916) .....	155
(324) .....	134	(3917) .....	155
(325) .....	135	(3918) .....	156
(326) .....	135	(3919) .....	156
(327) .....	135	(391A) .....	156
(328) .....	136	(391B) .....	156
(331) .....	136	(391C) .....	156
(332) .....	137	(391D) .....	157
(333) .....	137	(391E) .....	157
(334) .....	137	(391F) .....	157
(335) .....	137	(391G) .....	158
(336) .....	138	(391H1) -(391M1) .....	158
(337) .....	138	(391H-391M) .....	158
(338) .....	138	(391N) .....	158
(339) .....	139	(391P) .....	158
(33A) .....	139	(392) .....	81, 159
(33B) .....	139	(3921) .....	159
(33C) .....	140	(3922) .....	159
(33D) .....	142	(392A) .....	159
(33E) .....	142	(392A1) .....	159
(33F) .....	142	(392A2) .....	159
(33G) .....	142	(392A3) .....	159
(33H1) .....	142	(392A4) .....	159
(341) .....	144	(392A5) .....	159
(342) .....	144	(392A6) .....	160
(343) .....	144	(392A7) .....	160
(344) .....	145	(392A8) .....	160
(345) .....	145, 146	(392A9) .....	160
(346) .....	145	(392B) .....	160
(347) .....	145	(392B1) .....	160
(348) .....	145	(392B2) .....	160
(351) .....	146	(392B3) .....	160
(354) .....	147	(392B4) .....	160
(356) .....	148	(392C) .....	160
(357) .....	148	(392D) .....	160
(361) .....	148	(392E) .....	160
(362) .....	149	(392F) .....	160
(363) .....	149	(392F1) .....	161
(364) .....	149	(392F2) .....	161
(365) .....	149	(392F3) .....	161
(366) .....	149	(392F4) .....	161
(367) .....	149	(392F5) .....	161
(368) .....	149	(392F6) .....	161
(369) .....	149	(3AA) .....	162
(371) .....	150	(3AG) .....	163
(372) .....	150	(410) .....	165
(373) .....	150	(411) .....	165
(380) .....	151	(412) .....	165
(381) .....	151	(413) .....	165
(383) .....	151	(414) .....	165
(384) .....	151	(415) .....	165
(385) .....	151	(416) .....	166
(386) .....	151	(4162) .....	166
(387) .....	152	(417) .....	166
(388) .....	152	(4171) .....	166
(389) .....	152	(4172) .....	166
(390) .....	154	(418) .....	167
(391) .....	81, 154	(4181) .....	167
(3911) .....	154	(4182) .....	167
(3912) .....	154	(419) .....	167

(4191) .....	167	(621) .....	192, 193, 194, 195, 196
(4192) .....	167, 168	(640) .....	197
(41A) .....	167	(641) .....	198
(41B) .....	168	(642) .....	198
(41C) .....	168	(645) .....	198
(421) .....	169	(650) .....	198
(4211) .....	169	(6514) .....	198
(4212) .....	169	(711) .....	204
(422) .....	169	(712) .....	204
(423) .....	169, 170	(713) .....	204
(424) .....	170	(714) .....	204
(511) .....	171	(715) .....	204
(512) .....	172	(716) .....	204
(513) .....	173	(717) .....	204
(514) .....	175	(718) .....	204
(515) .....	175	(719) .....	204
(516) .....	175	(71A) .....	205
(517) .....	175	(71B) .....	205
(518) .....	175	(720) .....	205
(519) .....	175	(721) .....	205
(51A) .....	175	(722) .....	206
(51B) .....	175	(723) .....	207
(51C) .....	175	(724) .....	207
(51D) .....	176	(725) .....	208
(51D1) .....	176	(726) .....	208
(51D2) .....	176	(727) .....	208
(51D3) .....	176	(728-72A) .....	208, 209
(51E) .....	176	(730) .....	209
(51E1) .....	176	(731) .....	209
(51E2) .....	176	(7311) .....	209
(520) .....	177	(732) .....	209
(521) .....	142, 143, 177	(733) .....	209
(522) .....	179	(7331) .....	210
(529-52H) .....	179	(800) .....	210
(530) .....	179	(811-81N) .....	211
(531) .....	179	(8A0) .....	211
(532) .....	180	(900) .....	212
(533) .....	180	(920) .....	212
(534) .....	181	(922) .....	212, 213
(535) .....	182	33F .....	142
(536) .....	182	Minimum Frequency .....	138
(537) .....	182	Modbus .....	85
(5371) .....	182	Modbus/TCP .....	229
(5372) .....	182	Monitor function	
(540) .....	182	Alarm Select .....	168
(541) .....	182	Auto set .....	167
(542) .....	184	Delay time .....	165
(551) .....	185	Max Alarm .....	165
(552) .....	185	Overload .....	71, 165
(553) .....	185	Ramp Enable .....	165
(55D) .....	185	Response delay .....	165, 166, 168
(561) .....	186	Start delay .....	165
(562) .....	186	Motor cables .....	33
(563-56G) .....	186	Motor cos phi (power factor) .....	107
(600) .....	186	Motor data .....	106
(610) .....	186	Motor frequency .....	107
(611) .....	187	Motor I2t Current .....	220
(611) - (614) .....	186	Motor identification run .....	108
(6111) .....	187	Motor lost .....	169, 170
(6112) .....	189	Motor Potentiometer .....	148, 177
(6113) .....	191	Motor potentiometer .....	177
(6114) .....	191	Motor protection .....	120
(6115) .....	191, 192	Motor PTC .....	53, 54, 116

Motor ventilation .....	107
Motors .....	7
Motors in parallel .....	48
MotPot .....	137
Multi-motor application .....	102

## N

Nominal motor frequency .....	144
-------------------------------	-----

## O

Operation .....	101
Options .....	57, 225
I/O Board .....	228
Output chokes .....	229
Output Voltage .....	204
Overload .....	71, 165
Overload alarm .....	71

## P

Parameter sets	
Load default values .....	117
Load parameter sets from Control Panel 118	
Parameter Set Selection .....	65
Select a Parameter set .....	116
PI Autotune .....	150
PID control .....	76
PID Controller .....	151
Closed loop PID control .....	151
Feedback signal .....	151
PID D Time .....	151
PID I Time .....	151
PID P Gain .....	151
Priority .....	67
Process Protection .....	169
Process Value .....	204
Product standard, EMC .....	10
Programming .....	97
PT100 Inputs .....	115, 116
PTC/PT100 board .....	228
Pump .....	123
Pump and fan control .....	81
Pump Cleaning .....	159
Pump cleaning .....	81, 159
Pump size .....	78
Pump/Fan Control .....	154

## Q

Quick Setup Card .....	7
------------------------	---

## R

Reference	
Frequency .....	169
Motor potentiometer .....	177
Reference signal .....	101, 132
Set reference value .....	132
Torque .....	169
View reference value .....	132
Reference control .....	101
Reference signal .....	102, 103
Relay output .....	185
Relay 1 .....	185
Relay 2 .....	185

Relay 3 .....	185
Release speed .....	142
Remote control .....	67
Reset command .....	177
Reset control .....	103
Resolution .....	100
RFI mains filter .....	33
Rotation .....	104
RS232/485 .....	125
RTC- Real time clock .....	229
RUN .....	94
Run command .....	94
Run Left command .....	177
Run Right command .....	177
Running motor .....	139

## S

Security .....	131
Serial communication .....	229
Settle Time .....	157
Setup menu .....	97
Menu structure .....	96
Shaft power .....	204
Signal ground .....	249
Single-ended connection .....	56
Software .....	212
Speed .....	204
Speed Mode .....	101
Spinstart .....	139
Standards .....	9
Standby supply board .....	229
Start/Stop settings .....	136
Status indications .....	91
Stop categories .....	83
Stop command .....	177
Stripping lengths .....	39
Switches .....	51
Switching in motor cables .....	35

## T

Technical Data .....	231, 283
Terminal connections .....	50
Test Run .....	108
Time .....	94, 214
Timer .....	155
Top cover .....	230
Torque .....	146
Torque Ramp .....	148
Trip .....	94
Trip causes and remedial action .....	218
Trip Message log .....	210
Trips, warnings and limits .....	217
Twisted cables .....	57
Type code number .....	8

## U

Underload .....	71
Underload alarm .....	165
Unlock Code .....	103
Upper Band .....	155
Upper Band Limit .....	156

**V**

V/Hz Mode .....	101
Vector Brake .....	142
Ventilation .....	107
View reference value .....	132
Voltage .....	51
VSD Data .....	212

**W**

Weekday .....	94, 214
Wifi options .....	129
Wireless .....	129
Wireless mode .....	129
Wiring .....	77



## TECHNICAL CENTERS

### NORDIC

#### CG Drives & Automation

Mörsaregatan 12  
Box 222 25  
SE-250 24 HELSINGBORG  
Sweden  
Phone: +46 42 16 99 00  
info.se@cgglobal.com

### CENTRAL EUROPE

(Germany, Austria, Switzerland)

#### CG Drives & Automation

Gießbergweg 3  
D-38855 WERNIGERODE  
Germany  
Phone: +49 (0)3943-920 50  
info.de@cgglobal.com

### BENELUX

#### CG Drives & Automation

#### Netherlands BV

Savoort 15  
5541 SK Reusel  
The Netherlands  
Phone: +31 (0)497 389 222  
info.nl@cgglobal.com

### INDIA

#### CG Power and Industrial Solutions Ltd.

#### Drive & Automation Division

Plot. No, 09, Phase II, New Industrial Area  
462046 MANDIDEEP  
India  
Phone: +91 748 042 642 1  
drives.service@cgglobal.com

### CG Drives & Automation Sweden AB

Mörsaregatan 12  
Box 222 25  
SE-250 24 Helsingborg  
Sweden  
T +46 42 16 99 00  
[www.emotron.com/www.cgglobal.com](http://www.emotron.com/www.cgglobal.com)

Document set: 01-7516-01r2  
Instruction manual: 01-7492-01r2  
Quick setup card: 01-7494-01r1  
2026-03-26